



PDHonline Course E321 (2 PDH)

Ground Fault Circuit Interrupters

Instructor: Lee Layton, P.E



2013

PDH Online | PDH Center

5272 Meadow Estates Drive
Fairfax, VA 22030-6658
Phone & Fax: 703-988-0088

www.PDHonline.org
www.PDHcenter.com

An Approved Continuing Education Provider

Ground Fault Circuit Interrupters

Lee Layton, P.E

Table of Contents

<u>Chapter</u>	<u>Page</u>
Introduction	3
Theory of Operation	5
GFI Characteristics	13
Operational Issues	19
Summary	23

Introduction

The physical nature of electricity is to seek the shortest path to ground. If a person makes contact with an energized conductor he may become a ready path for the current to flow to ground risking an electric shock or death from electrocution. In a residential environment the most likely cause of being shocked or electrocuted comes from an internal short in an appliance such as an electric drill, or from a damaged wire on an appliance or extension cord. The degree of current flowing through the person is dependent on the conditions at the point of contact. If the person is standing on a wet or damp floor in bare feet, the risk is much greater than if the person is wearing rubber soled shoes. Leaning against a metal appliance (e.g. washing machine) or contacting a metal pipe also increases the risk of electrocution. Of course, wearing rubber soled shoes and not contacting a metal appliance does not guarantee a shock or electrocution will not occur.

It only takes an amazing small amount of electric current to kill a person. Exposure to currents as low of 100 milliamps (ma) for only two seconds can cause death. Larger currents can cause death in much shorter times and currents as low as 10ma may temporarily paralyze muscles preventing the person from being able to release the appliance or source of the electric shock. The low currents and short times cannot be emphasized enough. It takes very little current for a very short time to kill someone. Consider someone using an electric hedge trimmer and he accidentally cuts the extension cord with the trim. The electricity has to go somewhere. If the trimmer has a metal case and he is standing on the ground, there's a very high risk that his body will form a short circuit—the path of least resistance for the current to flow through—creating a very strong likelihood that he will feel an electric shock or risk electrocution.

A *ground fault circuit interrupter* (GFCI) is an electronic device that can operate quickly to prevent electric shocks from electrical shorts. During normal operation of an electrical appliance, the current flowing through the conductors into a GFCI generally equals the flow of current returning from the appliance to the GFCI. However, if a “short” occurs in the appliance, or the cord, an imbalance is created between the current going to the device from the GFCI and the current returning to the GFCI. A GFCI is a device that can detect this imbalance in current flow, and, once the imbalance is detected, the GFCI opens the circuit so that no electricity can flow through the circuit, preventing electric shock or electrocution.

A professor of electrical engineering at the University of California, Charles Daiziel, invented the modern ground fault circuit interrupter in 1961. A form of “imbalance detectors” were in use prior to this time in special applications such as mining operations, however, the device designed by Daiziel became the basis for residential GFCI’s. Daiziel estimated the electrical shock hazards to humans and developed a safe current-time envelope for ventricular fibrillation and used this information to design his GFCI. Daiziel’s GFCI used a transistorized circuit to provide quick detection and tripping times for current imbalances.

Early GFCI’s were integrated into circuit breakers. These first generation units suffered from many false trips due to the poor alternating current characteristics of 120 volt insulations, especially in circuits having longer cable lengths. So much current leaked along the length of the conductors’ insulation that the breaker might trip with the slightest increase of current imbalance.

Later the circuitry was added to duplex electrical outlets and has become the ubiquitous GFCI in residential applications. Today, GFCI's are found in panel mounted circuit breakers, outlets, and in-line in the cord of some high risk devices such as hair dryers.

National Electrical Code requires GFCI devices intended to protect people to interrupt the circuit if the leakage current exceeds a range of 4-6 mA of current (the trip setting is typically 5 mA.) GFCI devices which protect equipment (not people) are allowed to trip as high as 30 mA of current.

Ground Fault Circuit Interrupters are known by other names around the world. A few of the common names, where this name may be used, is shown below,

<u>Name</u>	<u>Description</u>	<u>Location</u>
GFCI	Ground Fault Circuit Interrupter	North America
RCD	Residual Current Device	Europe/Australia
RCCB	Residual Current Circuit Breaker	Europe
RCBO	Residual Current Circuit Breaker with overcurrent protection	Europe
ELCB	Earth Leakage Circuit Breaker	Asia

In the first chapter we will look at the theory of operation of GFCI's. In chapter two, we look at the specifications and characteristics of the different types of GFCI's. Chapter three covers code requirements, installation, and operational issues associated with GFCI's.

Theory of Operation

GFCI's operate by measuring the current balance between two conductors using a differential current transformer. The device will open its contacts when it detects a difference in current between the live conductor and the neutral conductor. The supply and return currents must sum to zero; otherwise, there is a leakage of current to somewhere else such as to earth/ground, or to another circuit, etc. This process is known as a residual current detection.

Residual current detection is complementary to over-current detection. Residual current detection does not provide protection for overload or short-circuit currents.

A good way to begin a discussion about how a GFCI operates is to consider the operation of a basic electrical transformer. In a simple transformer, two coils of wire are wrapped around an iron core. The coil supplying the transformer is called the primary coil and the other coil is known as the secondary coil. By using a different number of turns of wire around the core in the primary and secondary coils, a transformer can transform the primary voltage into a different voltage known as the secondary voltage. The secondary voltage can be either greater than or less than the primary voltage depending on the number of windings of wire around the core. There is not an electrical connection between the primary and secondary coils; they are connected via the magnetic flux that develops in the iron core due to the voltage impressed on the core from the alternating primary circuit. Figure 1 is a simplified schematic of an electrical transformer.

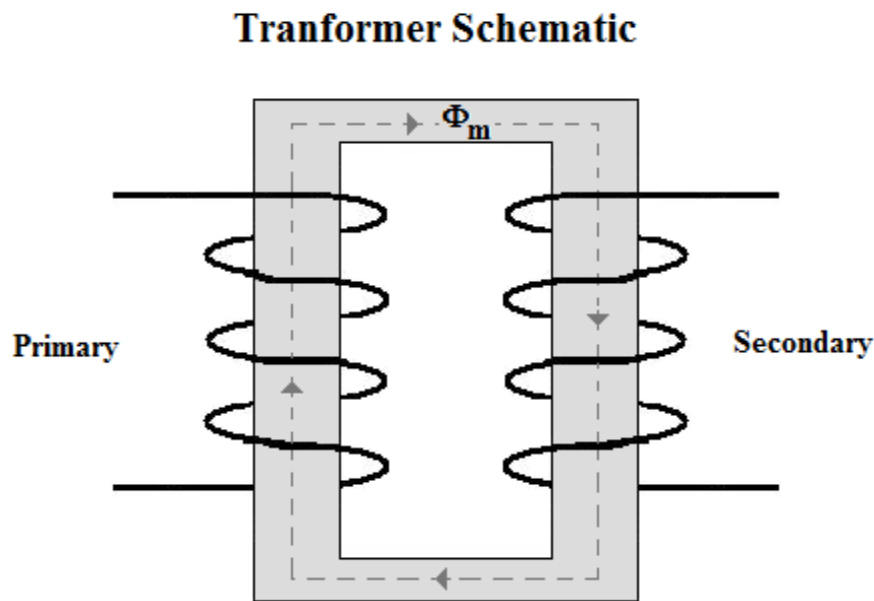

Figure 1

From Figure 1 we see that the alternating primary current flows around a coil on the left side of the transformer. Since this is an alternating current, it produces a magnetic field in the iron core. The magnetic flux, Φ_m travels in the core and is induced into the wires of the secondary coil on

the right side of the transformer. A voltage is produced in the secondary only when there is magnetic flux in the core.

To see how this concept applies to a GFCI, let's now look at Figure 2. In a GFCI, the hot and neutral conductors wrap around an iron core much like the one in a transformer. The hot conductor wraps around one side of the core and the neutral conductor wraps around the other side of the core. (In actual practice, the wiring is somewhat different, but for the purposes of illustration this concept is electrically correct.)

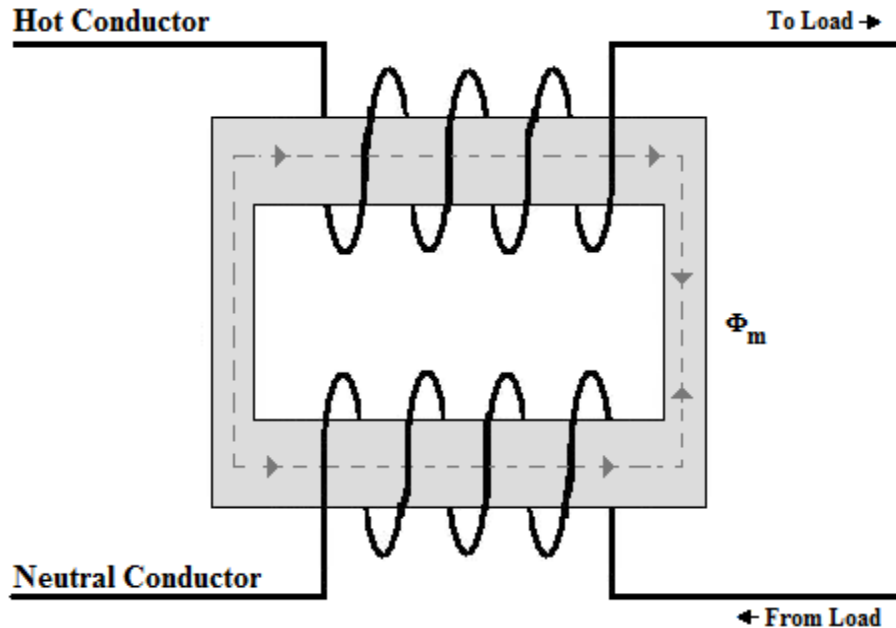

Figure 2

Figure 2 is similar to Figure 1, except that the core is not being used to develop a voltage in the secondary. In this case, the hot conductor passes around the iron core to the load and then the current is returned via the neutral conductor, which is also wrapped around the iron core. The primary, or hot, conductor induces a magnetic field in the core just like a conventional transformer. However, the neutral current returning from the load also induces an equal and opposite magnetic field in the iron core. Under normal conditions, current flowing through the phase conductor is equal to the current returning through the neutral conductor. This means that there is no leakage out of the system. The current flowing into the device is equal to the current used by the load. The magnetic field generated by the phase wire is equal in amplitude and opposite in polarity to the neutral wire so the magnetic fields generated cancel each other out. There is no 'imbalance'.

Now look at Figure 3.

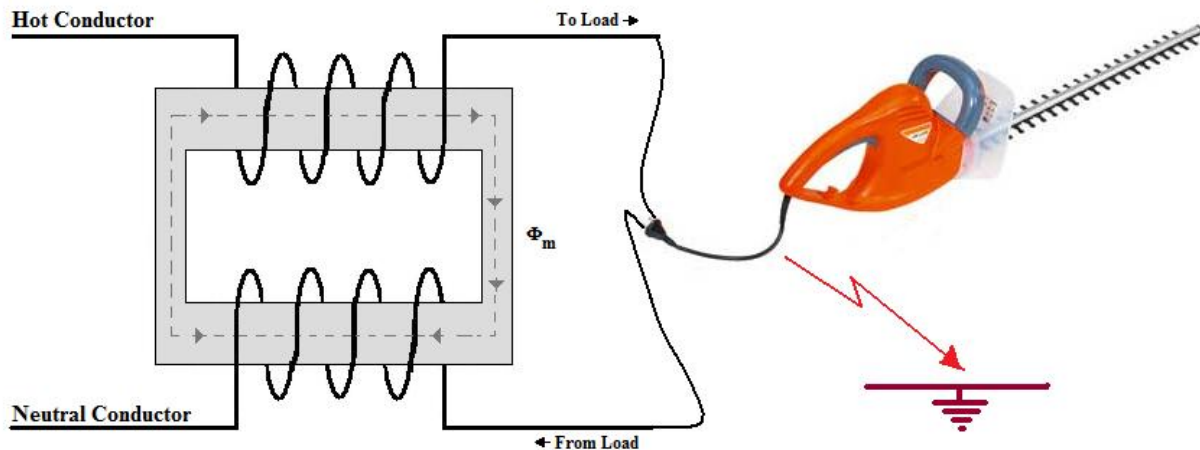

Figure 3

If the hot conductor passing through the transformer core and supplying an appliance is damaged, some of the current “leaks” out of the circuit – potentially through a person holding the appliance – and flows to earth ground. Current flowing through the phase conductor is not equal to the current returning through the neutral conductor. Current is being lost through an alternative return circuit to earth - possibly you! The current in one of the active conductors is equal to the current used by the load and the alternate return circuit, which is not equal to that returning through the other active conductor. As there is an imbalance of current, the magnetic fields of phase and neutral do not cancel each other out; therefore a magnetic field exists. This causes the sensor coil within the GFCI to generate a small current. This current in the sensor coil is in turn detected by the sensor circuit. If the sensed current is above a predetermined level then the sensor circuit sends a signal to the solenoid, which causes the contacts to open, or 'trip'.

Because of this “leak”, there will be unequal currents flowing in the hot and neutral conductors and the neutral conductor will have less current flowing back through the transformer core. With the unequal current flow, the magnetic fields in the iron core will no longer cancel each other and a net magnetic field will exist in the core.

Looking at Figure 4, we see that it is identical to Figure 3 except that we have added another winding around the core.

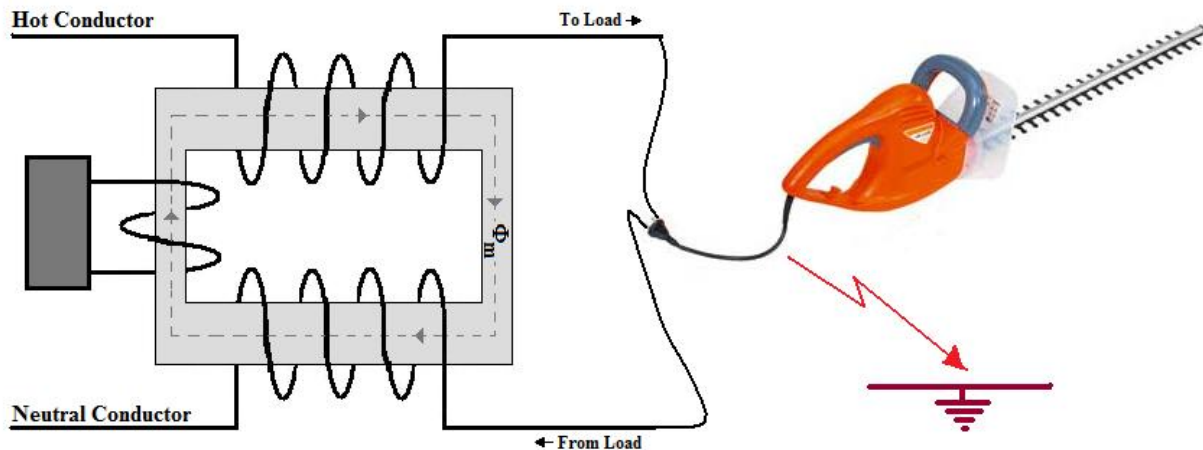

Figure 4

This third coil is called the *detector coil* and it's wired up to a very fast electromagnetic relay. When a current imbalance occurs, the magnetic field induced in the core causes an electric current to flow in the detector coil. That current triggers the relay which can be used to cut off the power to the damaged appliance.

Figure 5 is a somewhat more complete view of a GFCI. You will notice in Figure 5 that the transformer is a round device called a longitudinal transformer (also known as a toroid.) The hot and neutral conductors pass through the longitudinal transformer, but are not wound around the core as shown in the previous examples. The effect is the same however. Passing the conductors through the toroid is considered to be the same as winding the conductor around the core one time.

Toroid transformers are built around a ring-shaped core, which, depending on operating frequency, is made from a long strip of silicon steel or perm-alloy wound into a coil, powdered iron, or ferrite.

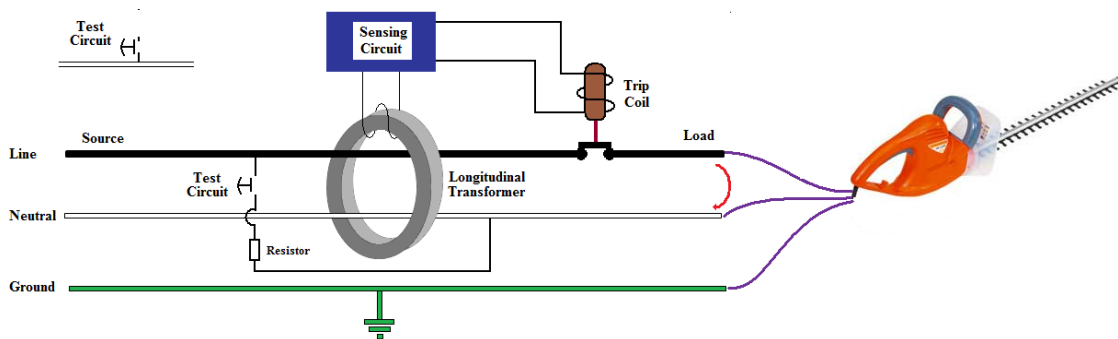

Figure 5

The longitudinal transformer also has a winding, known as the detector coil, which supplies the sensing circuit. The sensing circuit must be very sensitive to pick up the required current imbalance. A typical circuit may have 10 amps or more flowing through it and we expect the GFCI to operate on an imbalance of only 5 MA, which is only 0.05% of the full load current! The required sensitivity is accomplished using a fast acting electronic circuit with an integrated

circuit called an *op-amp comparator*. One such IC is the LM1851 made by National Semiconductor. The op-amp comparator provides an output to drive a special trip coil circuit, which will operate the trip coil.

Once the trip coil receives a signal from the sensing circuit, the coil opens and latches contacts in both the hot conductor and the neutral conductor (for simplicity, the trip coil is just shown operating the hot conductor in Figure 5.) Theoretically only the hot conductor would need to be interrupted; GFCI are generally designed to interrupt both conductors in case someone has mistakenly wired a circuit backwards and is using the white conductor as the hot conductor instead of the black conductor.

Notice also in Figure 5, that there is a small test circuit switch and resistor with one connection ahead of the longitudinal transformer and the other connection behind the longitudinal transformer in the GFCI. This switch, when depressed, will close a circuit across the hot and neutral creating a short, the magnitude of which is limited by the resistor. The short will create a current imbalance of approximately 8ma and, just like a damaged conductor, should trip the GFCI if the GFCI is working properly. The test switch is on the face of the GFCI so that end-users may test the device.

In Figure 5, we see that the current is flowing from the hot conductor through the device and returning through the neutral conductor, so no magnetic field is produced in the longitudinal transformer and the sensing circuit is not receiving any signal. Now, look at Figure 6. In Figure 6 we see that the appliance cord has a fault. Current flowing from the hot conductor to the appliance is now passing to the earth ground (green wire) possibly passing through the user. Some current continues to return through the neutral conductor. We now have an imbalance in current in the longitudinal transformer, so the sensing circuit is receiving a signal and passes current to the trip coil in interrupt the flow of electricity.

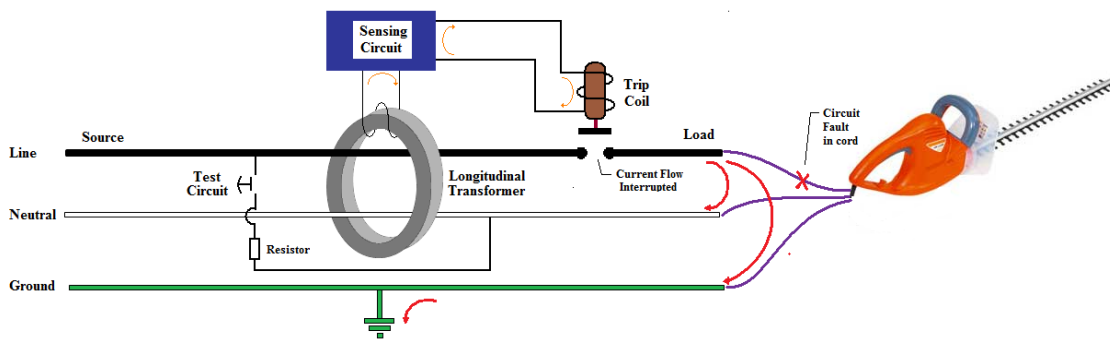

Figure 6

It should be noted that the green wire, or ground conductor, is not required for the proper operation of a GFCI. All that is required is that there is a difference in current flows between the hot and neutral conductor. Normally, we would expect this difference to flow in the ground wire, but it may just as well flow in the ground, or through a water pipe, etc.

As previously mentioned, the neutral conductor as well as the hot conductor is normally interrupted. The trip coil is designed to latch open and can only be reset by manually pushing a reset button on the GFCI.

Until now we have been working from electrical schematics to describe the operation of a GFCI. The following photographs show the actual internal components of a typical duplex outlet GFCI. Figure 7 shows a close up view of the longitudinal transformer and the hot and neutral conductors.

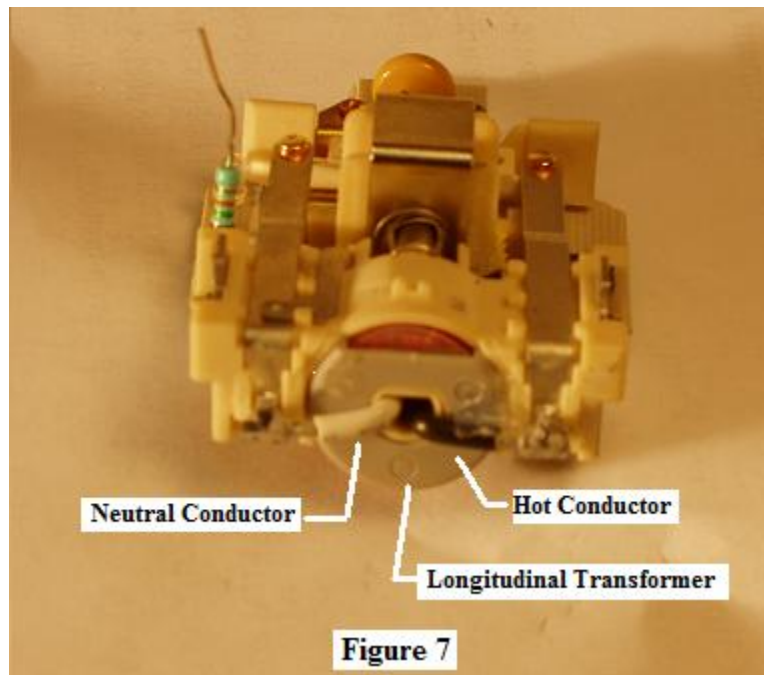

Figure 8 shows the trip coil circuitry and the trip coil itself. Also shown are the test circuit resistor and the LED indicator which indicates that the GFCI has operated.

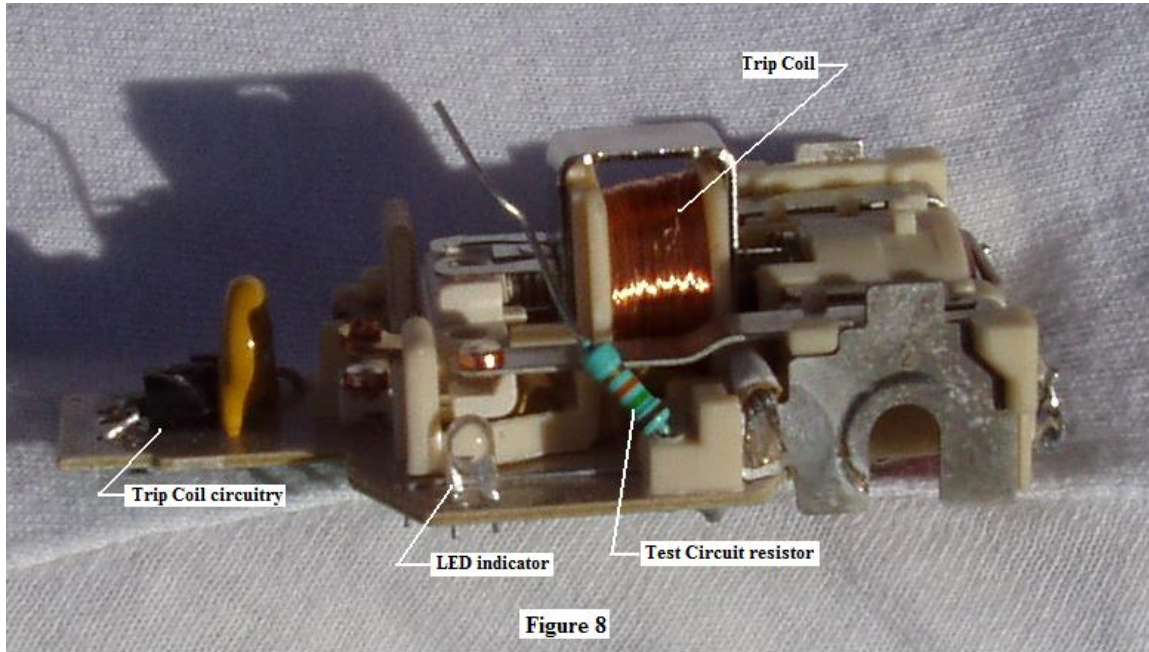

Figure 9 shows another view of the trip coil and the trip coil circuitry. In this image you can also see the GFCI contacts and the trip test contact.

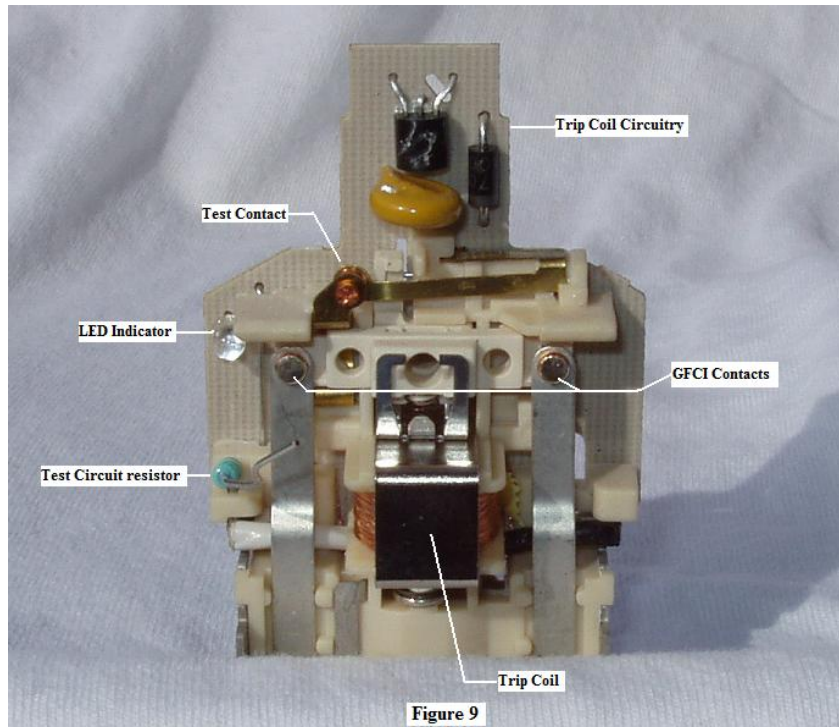
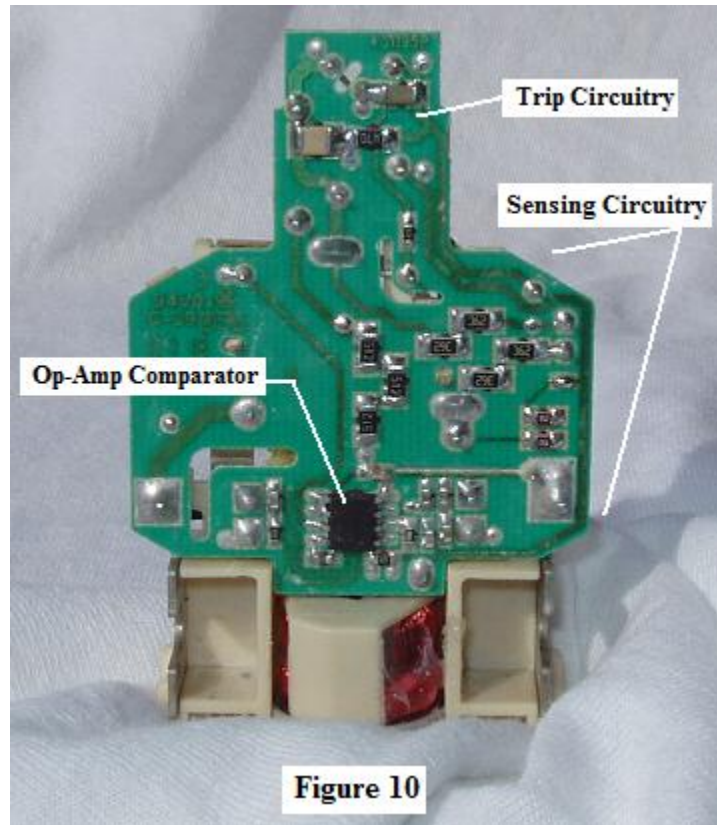

Figure 10 shows the back side of the GFCI, which shows the sensing circuit op-amp comparator and its associated diodes, resistors, and timing capacitors.



GFI Characteristics

In this section we look at the characteristics that describe the operating characteristics of a ground fault circuit interrupter. The characteristics include items such as the types of GFCI's, sensitivity, trip times, and latching characteristics.

GFCI Types

There are three basic types of GFCI's on the market for use in residential, commercial, and industrial applications: circuit breaker, wall receptacle, and portable.

Circuit breaker GFCI's are used in homes equipped with circuit breakers rather than fuses. The GFCI circuit breaker can be used as a replacement for a standard circuit breaker and can be installed in an electrical panel box to protect all receptacles on a particular branch circuit. Some homes are wired so that all bathrooms, for example, are on the same circuit. Installing a GFCI circuit breaker in the electrical panel box means that multiple GFCI's do not have to be installed. A circuit breaker GFCI serves two purposes: it shuts off electricity when there is a "ground-fault" and will also "trip" when the circuit is overloaded or shorted.



Electrical sockets with included GFCI's are becoming common, and in the U.S. they are required by law in wet areas. In North America, GFCI sockets are usually of the *decora* size, which is a style that harmonizes outlets and switches, so that there is no difference in size between an outlet cover and a switch cover. For example, using the *decora* size outlets, GFCI outlets can be mixed with regular outlets or with switches in a multi-gang box with a standard cover plate. Therefore, a *wall receptacle GFCI* is similar to a common wall outlet and is used in place of the standard duplex receptacle found in homes; it protects any appliance plugged into it or any other outlets that might be connected to it. The

wall receptacle GFCI has the same two outlets as common receptacles; in addition, it has two buttons, one with the word "test" and the other with the word "reset".

Portable GFCI's are frequently used in construction and outdoor settings where electric tools and appliances are being used. Electrical plugs which incorporate a GFCI are sometimes

installed on appliances which might be considered to pose a particular safety hazard, for example long extension leads which might be used outdoors or garden equipment or hair dryers which may be used near a tub or sink. Occasionally an in-line GFCI may be used to serve a similar function to one in a plug. Putting the GFCI in the extension lead provides protection at whatever outlet is used even if the building has old wiring. One kind of portable GFCI contains the GFCI circuitry in a self-contained enclosure with plug blades in the back and receptacle slots in the front. It can then be plugged into a receptacle and the electrical products are plugged into the GFCI.



Number of poles

The number of poles is based on the electrical configuration of the circuit being protected. GFCI's may use two poles for use on single phase supplies (phase and neutral), three poles for use on three phase supplies or four poles for use on three phase systems with a neutral.

Rated current

The rated current of a GFCI is chosen according to the maximum sustained load current it will carry. Typical residential outlet GFCI's are rated for either 15 or 20-amps.

Sensitivity

GFCI sensitivity is expressed as the rated residual operating current, noted $I_{\Delta n}$. Preferred values have been defined by the IEC, thus making it possible to divide GFCI's into three groups according to their residual operating current value.

- High sensitivity (HS)
 - Current: 6 – 10 – 30 mA
 - Application: Direct-contact / life injury protection
- Medium sensitivity (MS):
 - Current: 100 – 300 – 500 – 1000 mA
 - Application: Fire protection
- Low sensitivity (LS):
 - Current: 3 – 10 – 30 A
 - Application: Equipment protection

The notation, $I_{\Delta n}$ is the residual operating current for a GFCI. For a typical residential application this is 5ma.





Type

The international standard for residual current devices is IEC Standard 60755. This standard covers the general requirements for residual current operated protective devices and defines three types of GFCI depending on the characteristics of the fault current.

- Type AC: GFCI for which tripping is ensured for residual sinusoidal alternating currents
- Type A: GFCI for which tripping is ensured
 - for residual sinusoidal alternating currents
 - for residual pulsating direct currents
 - for residual pulsating direct currents superimposed by a smooth direct current of 0.006 A, with or without phase-angle control, independent of the polarity
- Type B: GFCI for which tripping is ensured as for type A
 - for residual sinusoidal currents up to 1000 Hz
 - for residual sinusoidal currents superposed by a pure direct current
 - for pulsating direct currents superposed by a pure direct current
 - for residual currents which may result from rectifying circuits
 - three pulse star connection or six pulse bridge connection
 - two-pulse bridge connection line-to-line with or without phase-angle monitoring, independently of the polarity

Underwriters Laboratory (UL) also has standards for the various types of GFCI's. For instance, UL 943 covers just Type A, single- and three-phase ground-fault circuit interrupters intended for protection of personnel, for use only in grounded neutral systems.

Some manufacturer’s specification sheets use a waveform schematic to show the applicable types of fault currents. Table 1 shows a few of the schematics used to describe certain waveforms.

Table 1 Waveform Schematics	
Waveform Schematic	Current Characteristics
	Alternating Current (60 Hz)
	Pulsed DC residual currents Positive and Negative half waves
	Phase-Controlled half-wave currents
	Half-wave current superimposed on a direct current
	Direct Current residual current

Trip Time

The two basic styles of tripping times are instantaneous, and delay tripping. Instantaneous tripping time means that when the GFCI senses an imbalance, it trips as soon as possible. Delayed tripping time is when the GFCI senses an imbalance, it starts a timer and if the imbalance still exists when the time is up the GFCI will trip. The time that the GFCI waits is dependent on the level of the imbalance. The higher the imbalance the faster the trip. The following shows the trip times required under the international standard, IEC 60755. The IEC defines two groups of devices based on the trip time characteristics. They are:

- General use (G)
 - GFCI’s with no time delay
 - Minimum break time: immediate
 - Maximum break time:
 - 200 ms for 1x IΔn
 - 150 ms for 2x IΔn
 - 40 ms for 5x IΔn
- Time delayed (T)

- GFCI's with a short time delay
- Minimum break time:
 - 130 ms for 1x I Δ n
 - 60 ms for 2x I Δ n
 - 50 ms for 5x I Δ n
- Maximum break time:
 - 500 ms for 1x I Δ n
 - 200 ms for 2x I Δ n
 - 150 ms for 5x I Δ n

Figure 11 shows the UL requirements for trip time versus current for a Class A GFCI. This figure also shows the impacts of different currents on humans.

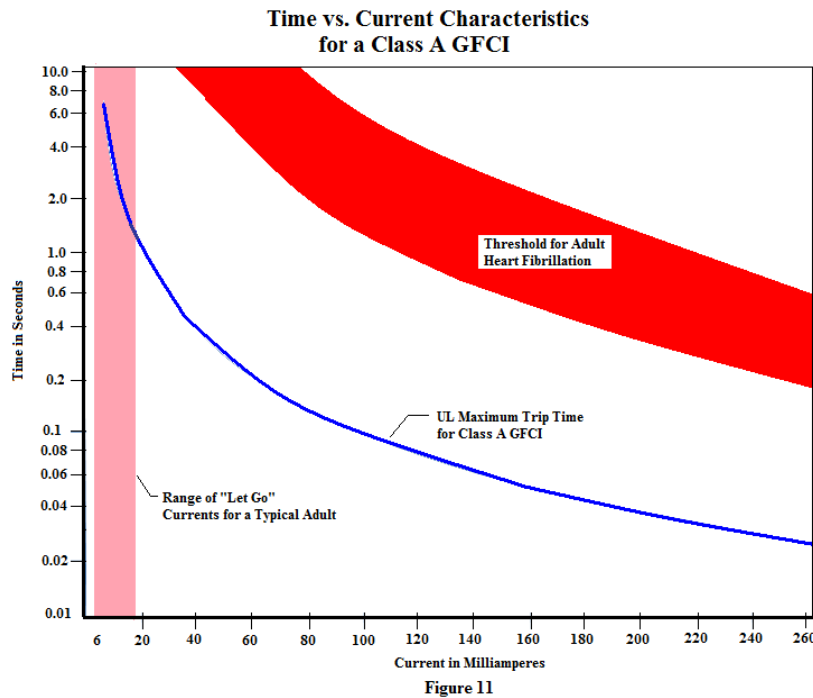

Most manufacturers exceed these requirements by a fairly wide margin. Many manufacturers list their Type A GFCI as having a response time of 25ms at 5ma.

Surge Current Resistance

The surge current refers to the peak current a GFCI is designed to withstand using a standard 8x20 μ s test impulse.

The IEC 61008 and IEC 61009 standards also impose the use of a 0.5 μ s/ 100 kHz damped oscillator wave (ring wave) to test the ability of residual current protection devices to withstand operational discharges with a peak current equal to 200 amp. With regard to atmospheric

discharges, IEC 61008 and 61009 standards establish the 8x20 μ s surge current test with 3,000 amp peak current but limit the requirement to time delay GFCI's only.

Loss of Power Status

GFCI's are also categorized by their behavior when a circuit is de-energized.

- *Non-latching* units will trip on power failure and not re-make the circuit when the circuit is re-energized. This type is used when the power-drawing equipment is regarded as a safety hazard if it is unexpectedly re-energized after a power failure e.g. lawn-mowers and hedge trimmers. Type A GFCI's are non-latching.
- *Latching units* will re-make the circuit when the circuit is re-energized. The second type may be used on equipment where unexpected re-energization after a power failure is not a hazard. An example may be the use of a GFCI on a circuit providing power to a food freezer, where having to reset a GFCI after a power failure may be inconvenient. Type B GFCI's are latching units and are used for fixed installations.

Operational Issues

In this section we look at a few of the requirements for GFCI's as spelled out in the National Electric Code (NEC®) and discuss typical wiring connections.

It is interesting to note that GFCI's provide protection whether or not the house wiring is grounded. A GFCI does not require an equipment-grounding conductor (green wire) since the GFCI detects an imbalance between the "hot" (black) conductor and the "neutral" (white) conductor. However, a GFCI circuit breaker cannot remove all risk of electric shock or fire. In particular, a GFCI alone will not detect overload conditions, phase to neutral short circuits or phase-to-phase short circuits. For these conditions, over-current protection such as a fuse or circuit breaker must be provided. Circuit breakers that combine the functions of a GFCI with overcurrent protection respond to both types of fault.

Important!
GFCI's do not protect persons from shock hazards where contact is between phase and neutral or between phase-to-phase conductors.

The device will only protect a person when the contact is between the phase and ground or neutral and ground.

Please remember that while a GFCI will help to protect against electric shock where current flows through a person from a phase to earth, it cannot protect against electric shock where current flows through a person from phase to neutral or phase to phase. For example if someone touches both live and neutral wires the GFCI cannot differentiate between current flows through an intended load from flows through a person.

National Electric Code (NEC®) Requirements

In 1968, the National Electric Code first required ground fault circuit interrupters for swimming pool lights. In 1973, added a requirement for GFCI's for outdoor receptacle circuits. Next were bathroom receptacles, which were added in 1975. Essentially, the NEC kept adding GFCI requirements anywhere water and electricity were in close proximity and later requirements added kitchens, basements, etc.

Article 210 is one of several NEC® code sections that address the use of GFCI's in residential applications. Article 210.8 is divided into three sections: (A) covers GFCI's in residential dwelling units, (B) addresses applications other than dwelling units, and (C) covers boat hoists.

Article 210.8 (A) lists the following applications that require GFCI's,

1. Bathrooms
2. Garages
3. Outdoor
4. Crawl spaces
5. Unfinished basements
6. Kitchens
7. Laundry rooms

8. Boathouses

As with most sections of the NEC®, there are exceptions and clarifications to these requirements.

Other pertinent sections of the NEC® include Article 680 which covers swimming pools, Article 550, which covers mobile homes, and Article 551 which covers recreational vehicles. This list is not exhaustive; there are other code sections that address GFCI installations.

GFCI Receptacle Connections

It is important for GFCI's to be wired correctly to ensure proper operation. There are a couple of methods that are considered appropriate wiring methods, but they provide different levels of protection, so care must be taken to ensure the wiring configuration used results in the desired level of protection.

Figure 12 shows the most common wiring configuration. In this configuration the *source* wiring is connected to the LINE side of the GFCI. Downstream receptacles can be protected by feeding them from the LOAD side of the GFCI.

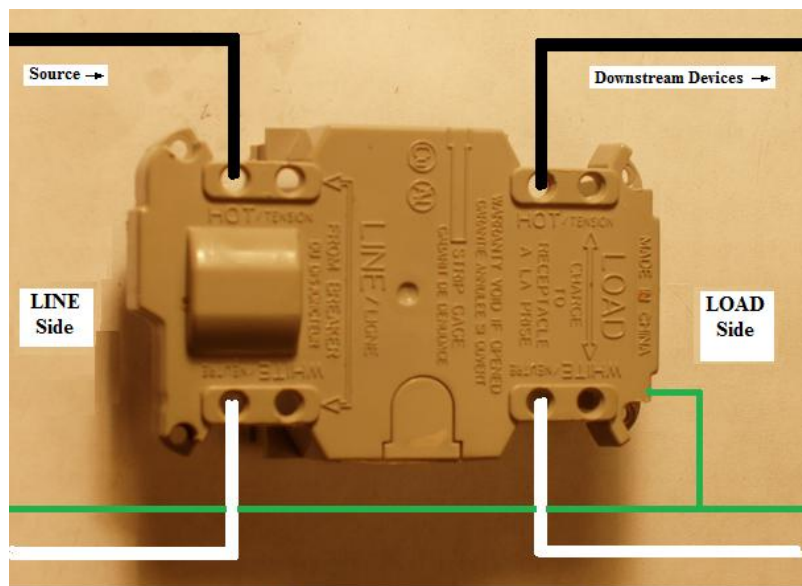

Connection to GFCI protecting downstream receptacles

Figure 12

A common wiring error is to wire the GFCI backwards so that the source line is connected to the LOAD side of the GFCI and the downstream devices are fed from the LINE side of the GFCI. In this case, neither the GFCI receptacle is protected nor the downstream devices.

Figure 13 is another wiring configuration that is also considered an appropriate wiring method. In this configuration, the *source* is wired into the LINE side of the GFCI. However the downstream devices are also wired into the LINE side of the GFCI. With this wiring

configuration the downstream devices are not protected by the GFCI. This is sometimes done in, say, a garage where a GFCI is required and there is also a dedicated receptacle that does not require ground fault protection, such as for a freezer.

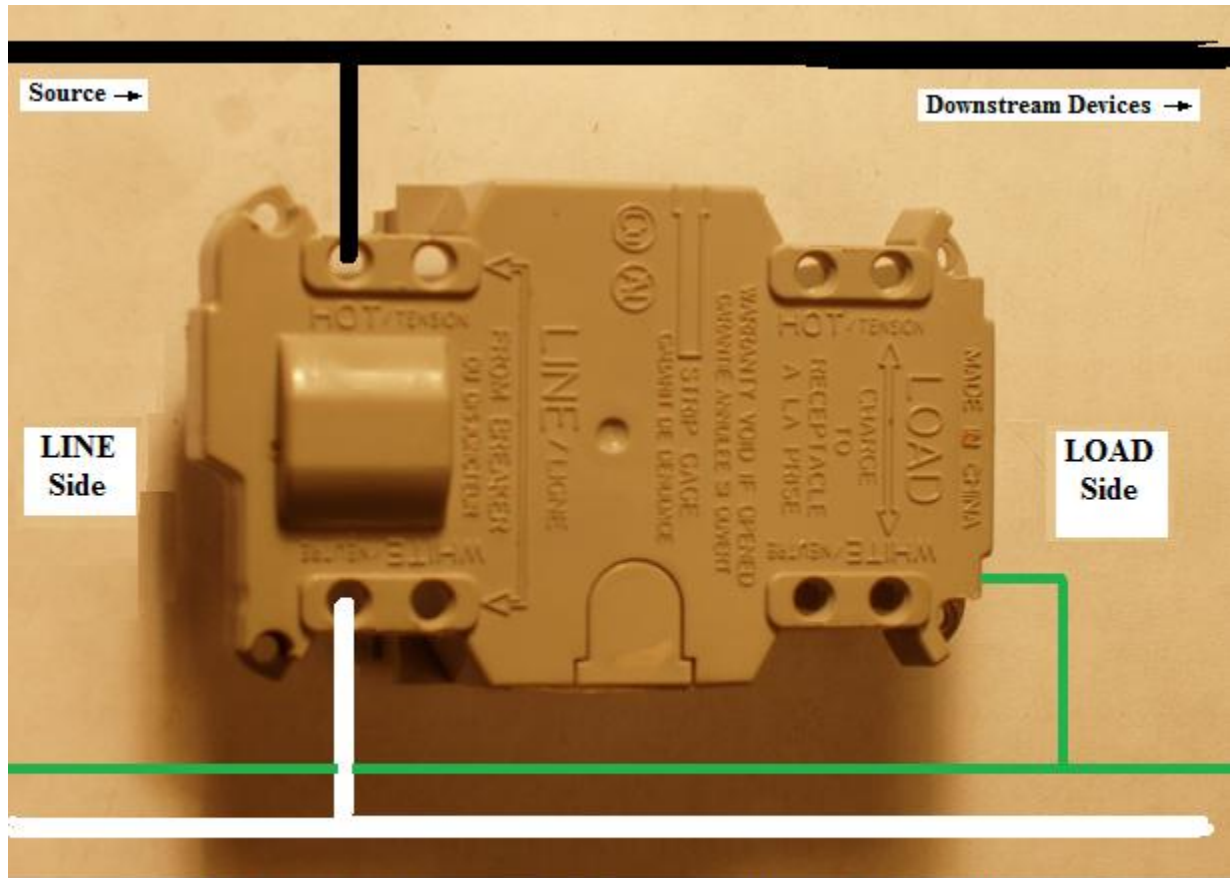

GFCI Receptacle Protected - Downstream Receptacles not Protected

Figure 13

Now look at Figure 14. In this figure the *source* is wired into the LOAD side of the GFCI and the downstream devices are served from the LOAD side of the GFCI. In this configuration, neither the GFCI receptacle nor the downstream devices are protected.

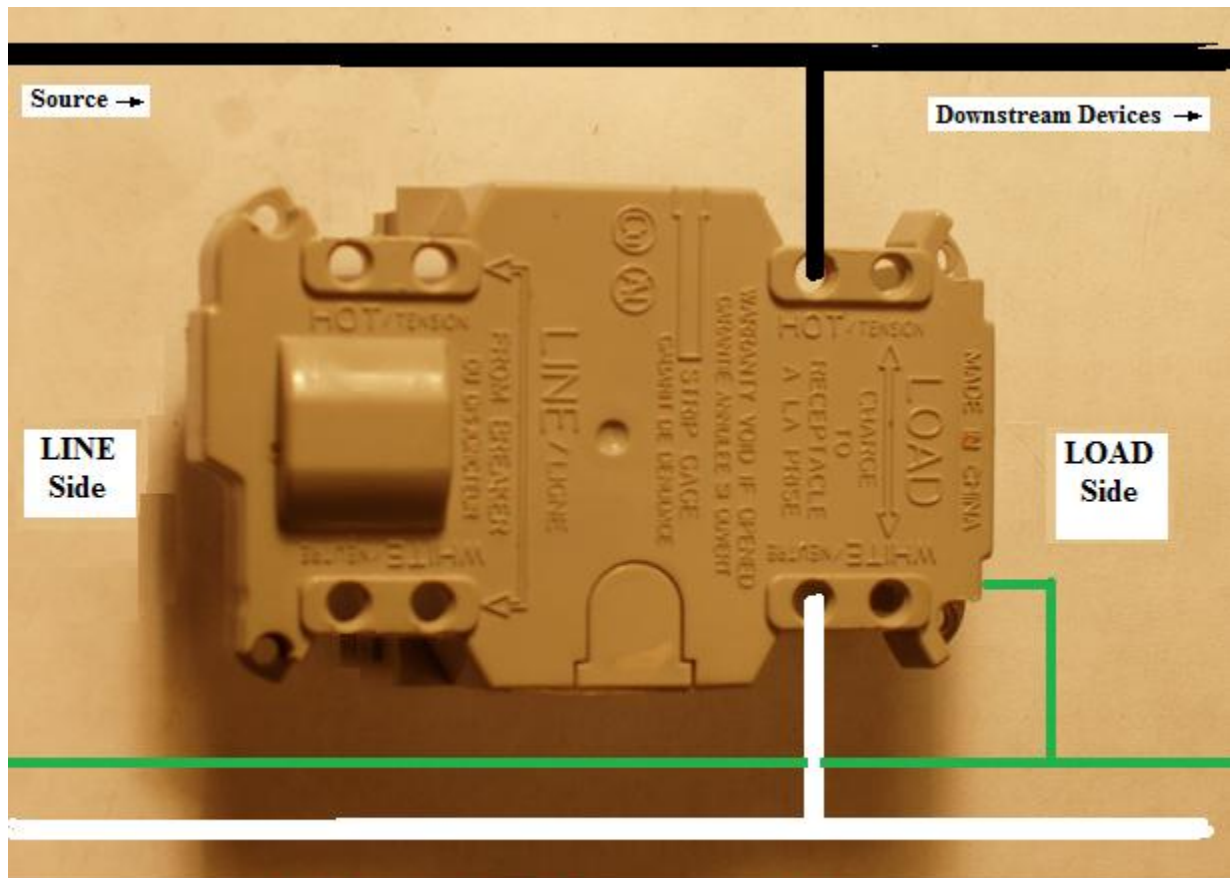

No Protection offered for any receptacle!

Figure 14

Summary

In 2000 it was estimated that there was 400 million GFCI devices installed in residential applications in the United States. This is amazing considering that in 1968 there were virtually no units installed. Ground Fault Circuit Interrupters have increased the safety of electrical circuits in homes and businesses. These devices quickly isolate circuits with current imbalances to prevent electrical shocks. Of course, there are conditions where a GFCI does not offer protection, but they are still a tremendous safety device.

Copyright © 2010 Lee Layton. All Rights Reserved.

+++