

SPRING REVERB TANKS EXPLAINED & COMPARED

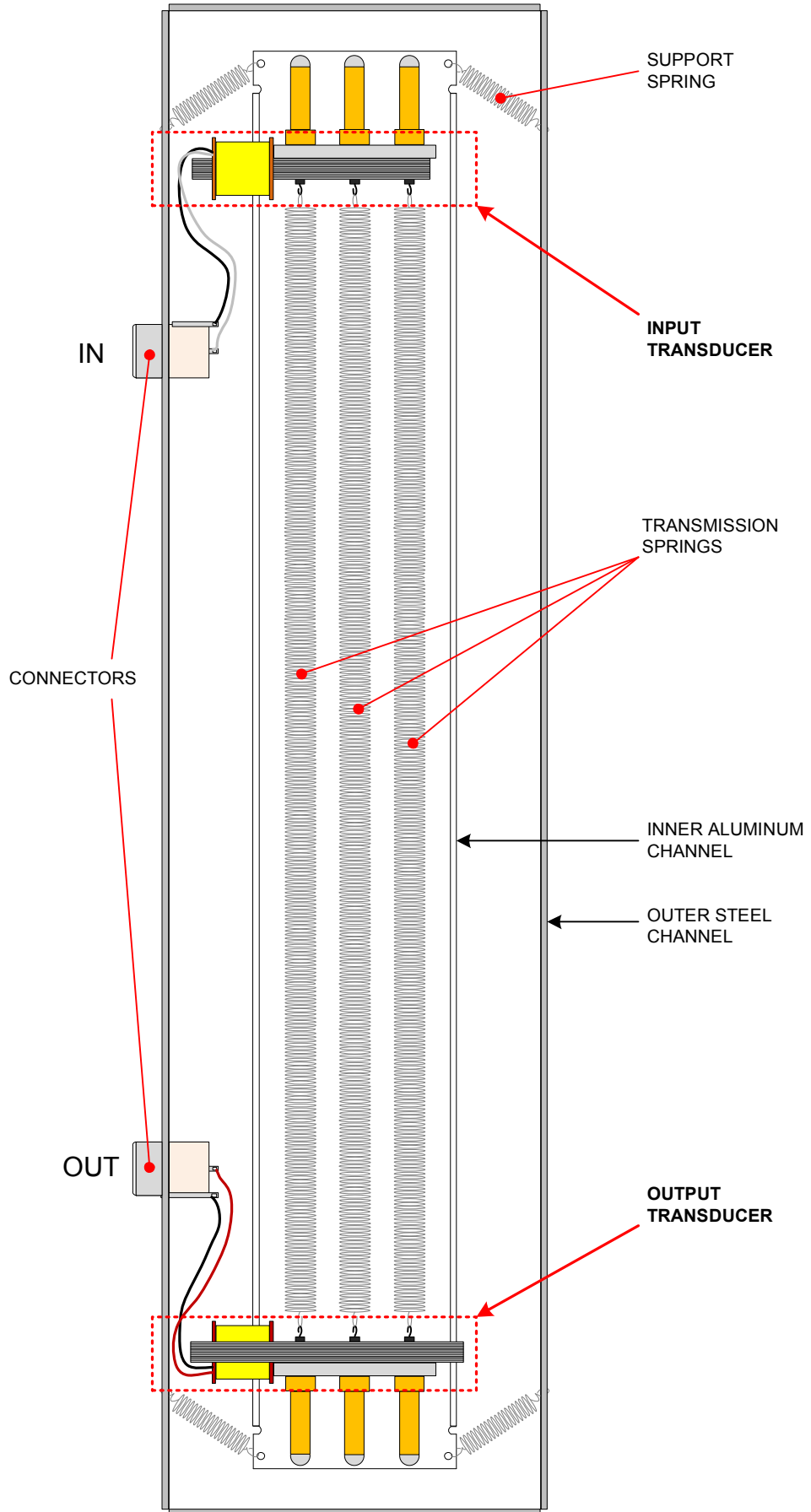

TABLE OF CONTENTS

	PAGE(S)
The Reverberation Effect	3
Electro-Mechanical Reverberation Devices: The Reverb Tank	
Historical use in Musical Instruments	
Spring Reverb Construction and Operation	
The Significance of Multiple Transmission Springs	4
Delay Time	
Decay Time	
Input and Output Impedance	4
Impedance @ 1kHz	
Approximate resistance of transducer coils	
Mounting Considerations	5, 6
Mechanical mounting considerations	
Electrical mounting considerations	
Connector Grounding/Insulating	6
Drive & Recovery Circuits	7, 8
Drive Circuit Design Considerations	
Recovery Circuit Design Considerations	
Accutronics® and MOD™ Part Numbering Systems	8, 9
Belton Part Numbering System	10
A Comparison of Reverb Tank Brands	11, 12
Physical Comparison	
Sound Characteristic Comparison	
Three Springs vs. Two Springs	

SOURCES

- 1) Vail, Mark; The Hammond® Organ: Beauty in the B; pp. 48, 50
- 2) Morrish, John; The Fender® Amp Book; pp. 25, 26
- 3) Scott, J. L. – Chief Engineer; Accutronics® document 126-00005 (February 1, 1978)
All technical information was taken from this Accutronics® document. Much of the original document has been paraphrased with additional drawings and explanations.

A listener standing some distance from a sound source will perceive sound that is actually a combination of direct sound and indirect sound that has been reflected from the boundaries of the listening area. The reflections are referred to as reverberation. Reverb can enhance the perceived sound from a source by adding depth, color and liveliness.

Reverb can be thought of as being composed of two parts:

- 1) Early reflections – shape the listener’s conception of room size
- 2) Cluttered reflections – convey the liveliness of a room

Imagine you are inside a large hall and you clap your hands once. The length of time required for the arrival of the very first reflections is called the **delay time** (usually on the order of tens of milliseconds, e.g. 33 ms) and is related to the volume of the room (or distance of the reflective surfaces from the listener). The number and density of reflections increases rapidly with time and they become cluttered while simultaneously decreasing in level until they are no longer audible. The length of time required for a sound to decrease in level by 60 dB is called the **decay time** (usually on the order of a few seconds, e.g. 3 s) and is related to the acoustical properties of the reflective surfaces in the listening area. For example, poured concrete walls will reflect more (absorb less) acoustic energy than drywall.

Electro-Mechanical Reverberation Devices: The Reverb Tank

Historical use in Musical Instruments

Laurens Hammond of Illinois popularized the use of artificial reverberation devices through his church organs in the 1940's and 1950's. “The early (pre-B-3®) Hammond® organs were sold to churches on the principle that organ music is greatly enhanced by reverberation, but the minister’s speech in the church is hampered by reverberation. Therefore, churches were designed to be acoustically dead, and the Hammond® organ had to have its own artificial reverberation.”¹

“[Reverberation] made its debut in the Fender® line as a separate item, using a spring [unit] bought from Hammond®, [in] 1961. It was first incorporated in a Fender® amplifier with the Vibroverb® of 1963 and then spread widely throughout the amp line, just as vibrato/tremolo had before it.”²

Spring Reverb Construction and Operation³

The main components used to produce the spring reverb effect are:

- Input and Output Transducers

Each transducer consists of a coil centered around a magnetic lamination and small cylindrical magnets centered in the air gap of the lamination.

- Transmission Springs

These components are mounted on an inner aluminum channel, which is connected by four small support springs to an outer steel chassis (or channel).

An electrical signal applied to the input transducer coil generates an alternating magnetic field which moves the transducer magnets. The magnets are mechanically coupled to transmission springs. The signal is reflected back and forth through the transmission springs with an amount of delay determined by each spring’s diameter, wire gauge and length. The moving magnets of the output transducer generate an alternating magnetic field which induces an electrical signal in the output transducer coil.

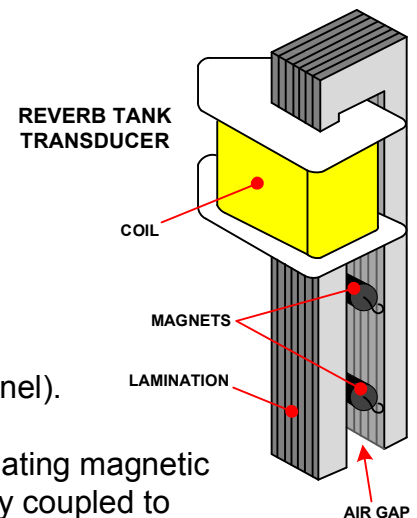

The Significance of Multiple Transmission Springs³

The use of multiple transmission springs helps to improve the reverb characteristics. A listener in a large hall with natural reverberation is not usually standing the same distance from each reflective surface. Naturally, there will be reflections from different surfaces having different delay times. The use of multiple transmission springs with different delay times serves to simulate a more natural ambiance, as well as improving the overall frequency response because one spring's response will fill voids or holes in the other spring's response.

Vintage Accutronics® specs list the following **delay times** per spring:

	TYPE 9 (3 Springs)	TYPE 4 (2 Springs)
SHORT	33 ms	33 ms
LONG	41 ms	41 ms
MEDIUM	37 ms	

Decay time should be selected to suit the application. The same reverberation decay time that enhances and adds liveliness to the sound of the guitar can make speech unintelligible.

General **decay time** suggestions traditionally used for specific instruments:

	DECAY TIME
GUITAR	Long (2.75 to 4.0 s)
ORGAN	Medium (1.75 to 3.0 s)
VOCALS	Short (1.2 to 2.0 s)

Input and Output Impedance³

Reverb tanks are supplied in a variety of input and output impedances (measured at 1kHz) to allow for flexibility in designing drive and recovery circuits. The input and output transducers can be characterized as essentially inductive, with impedance rising with increasing frequency (inductive reactance). When replacing the reverb tank in an existing amplifier design, it is important to match the original tank's input and output impedances as closely as possible. The reverb effect will sound poor or inaudible if the impedances are not matched.

	Input Impedance @ 1kHz		Output Impedance @ 1kHz	
	TYPE 4	TYPE 8 & 9	TYPE 4	TYPE 8 & 9
A	8 Ω	10 Ω	500 Ω	600 Ω
	1.0 Ω*		40 Ω*	
B	150 Ω	190 Ω	2,250 Ω	2,575 Ω
	25 Ω*		215 Ω*	
C	200 Ω	240 Ω	10,000 Ω	12,000 Ω
	30 Ω*		800 Ω*	
D	250 Ω	310 Ω		
	35 Ω*			
E	600 Ω	800 Ω		
	60 Ω*			
F	1,475 Ω	1,925 Ω		
	200 Ω*			

Because DC resistance can be easily measured with an ohm meter (and Impedance @ 1kHz cannot), it is sometimes useful to estimate the impedance by way of DC resistance.

* Approximate DC resistance of transducer coils can be used as a reference for input and output impedance if the original reverb tank is not labeled. The actual resistance of transducer coils may be different between manufacturers or production runs.

Mounting Considerations³

Because reverb tanks are electro-mechanical devices, their performance is affected by how they are mounted.

Mechanical mounting considerations:

- Weight of springs and displacement of transducer magnets along the air gap
- Isolation from vibrating surfaces
- Mechanical feedback through tight cable connections

Mounting Planes & Magnet Displacement

The ideal mounting plane for reverb tanks is one that allows the weight of the transmission springs to keep the transducer magnets centered along the air gap and not toward the lamination.

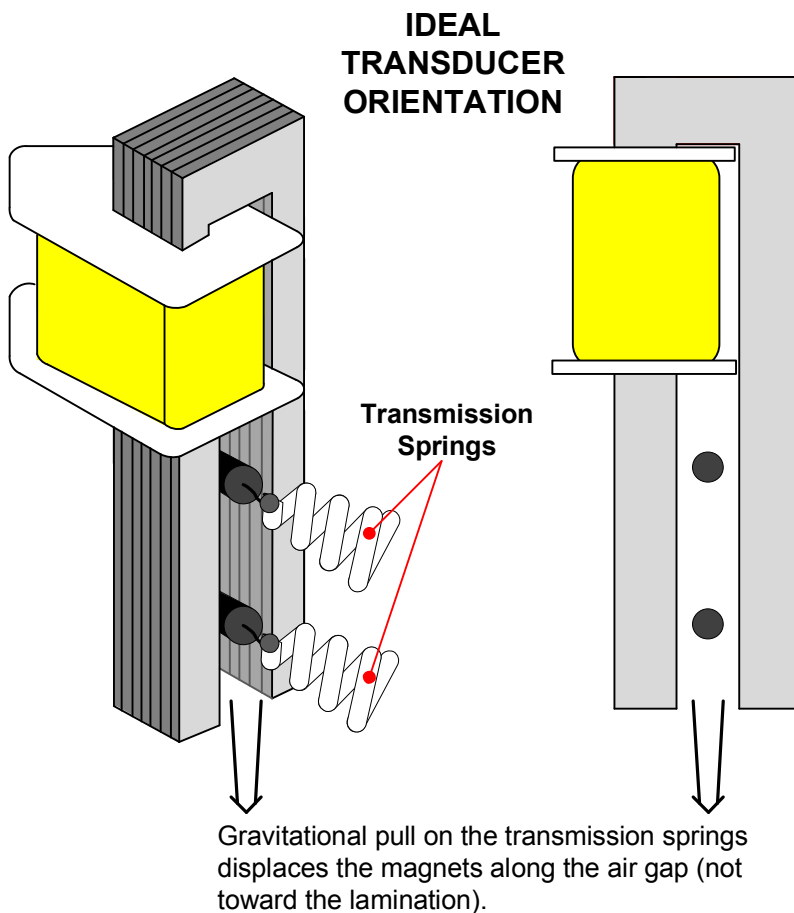

The reverb tank mounting plane that results in this ideal transducer orientation is referred to as “**Vertical Connectors Up**”.

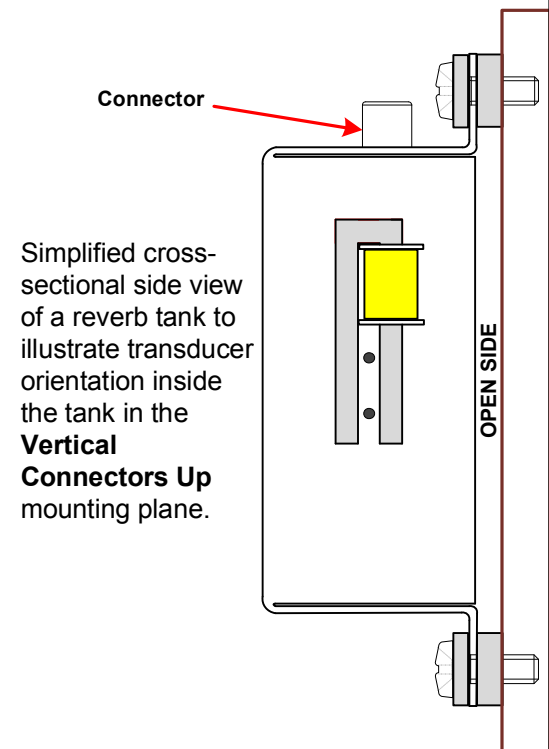

If the reverb tank cannot be mounted in the ideal “vertical connectors up” plane, the tank should be chosen with magnets that have been factory adjusted to be centered in the air gap for that specific mounting plane.

Simplified cross-sectional side view of a reverb tank:
Horizontal Open Side Down mounting plane.

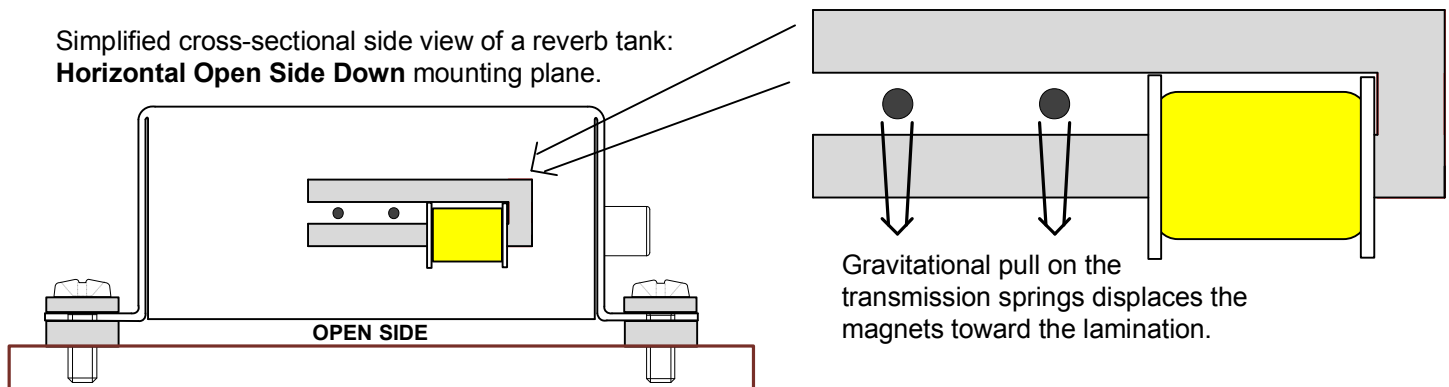

Mechanical Isolation:

The reverb tank should be isolated from vibrating surfaces as much as possible. Avoid mounting the outer channel of the reverb tank directly to the mounting surface by using grommets, rubber standoffs, reverb tank bag and liner or other products designed for mechanical isolation.

Avoid mounting on cabinet members that would tend to act as “sounding boards.” A small dimensioned rigidly supported surface is best.

Cable Connections:

Allow for slack in cables attached to the reverb tank to prevent forming mechanical feedback paths.

Electrical mounting considerations include:

- External Magnetic Fields

Even though the transducers are shielded by the outer steel channel, the output transducer end in particular should be kept away from transformer fields. The effectiveness of the shield varies with its orientation in an external magnetic field.

ORIENTATION OF TRANSDUCER IN EXTERNAL MAGNETIC FIELD FOR **MINIMUM PICKUP**

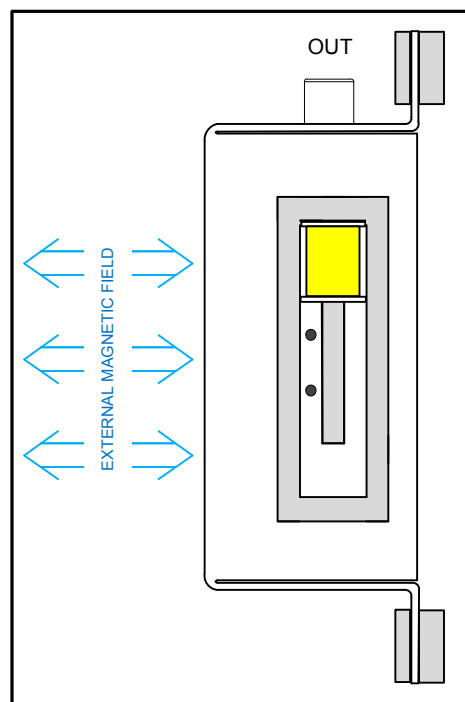

ORIENTATION OF TRANSDUCER IN EXTERNAL MAGNETIC FIELD FOR **MAXIMUM PICKUP**

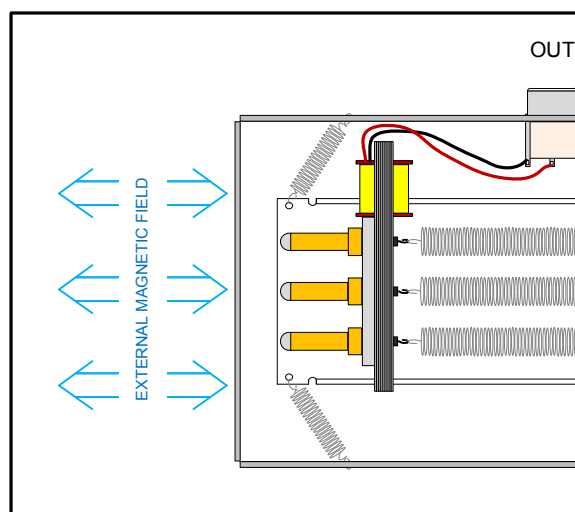

Connector Grounding/Insulating³

In order to suit any grounding scheme, reverb tank connectors come in all combinations of input and output insulated and non-insulated phono jacks (a.k.a. RCA jack). A non-insulated phono jack is one whose outer shell is grounded to the outer steel channel (chassis) of the reverb tank. Vintage Accutronics® specs recommend insulating both input and output connectors and grounding the tank chassis separately.

If the amplifier's connection to the reverb tank's phono jack shell is not at ground potential, it is important that the tank be chosen with an insulated connector at that connection point. If the amp's connection to the reverb tank's phono jack shell is at ground potential, either insulated or grounded connector may be used at that connection point.

Drive & Recovery Circuits

These schematics are examples of drive and recovery circuits from popular guitar amplifiers. There are many varieties of tube and solid state drive and recovery circuits used in guitar amplification resulting in different input and output impedances. It is important to match the original tank input and output impedance as closely as possible in order for the reverb effect to work properly.

Fender® Twin Reverb® 4AB3C1B

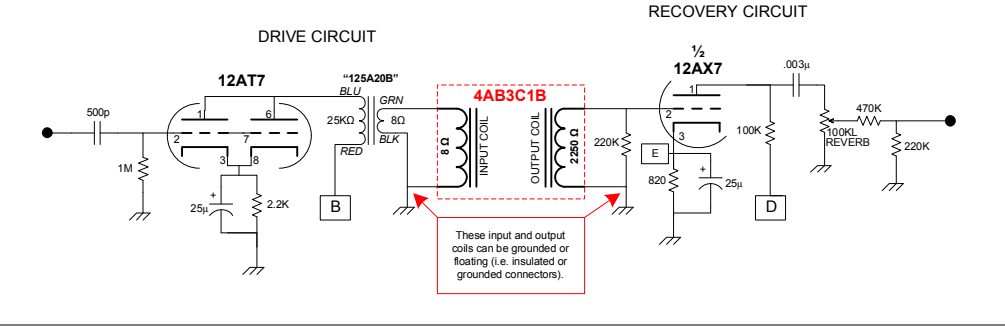

'63 Fender® Reverb® (Reissue Stand Alone) 4AB3C1C

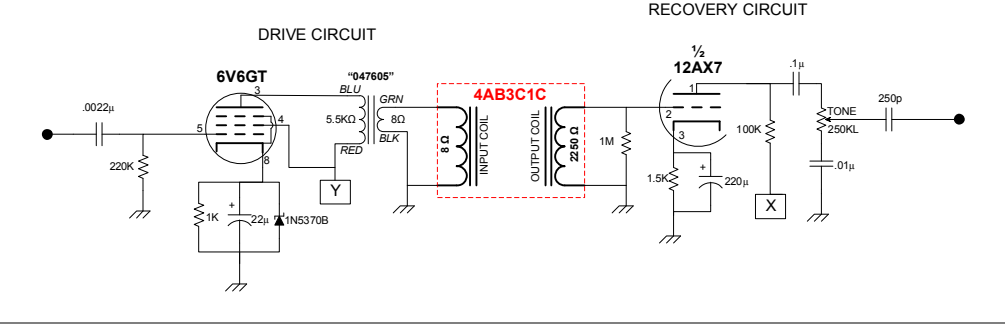

Fender® Blues Junior® 8EB2C1B

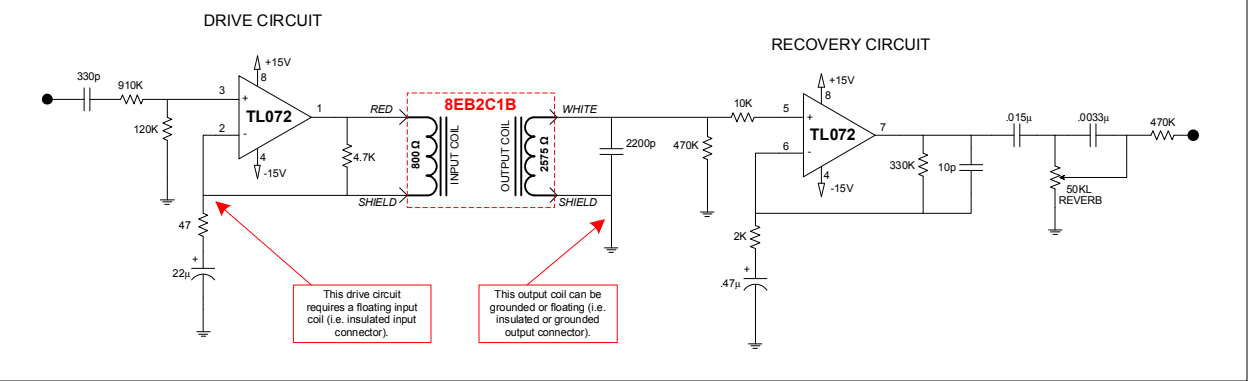

Marshall™ AVT50X™ 8DB2C1D

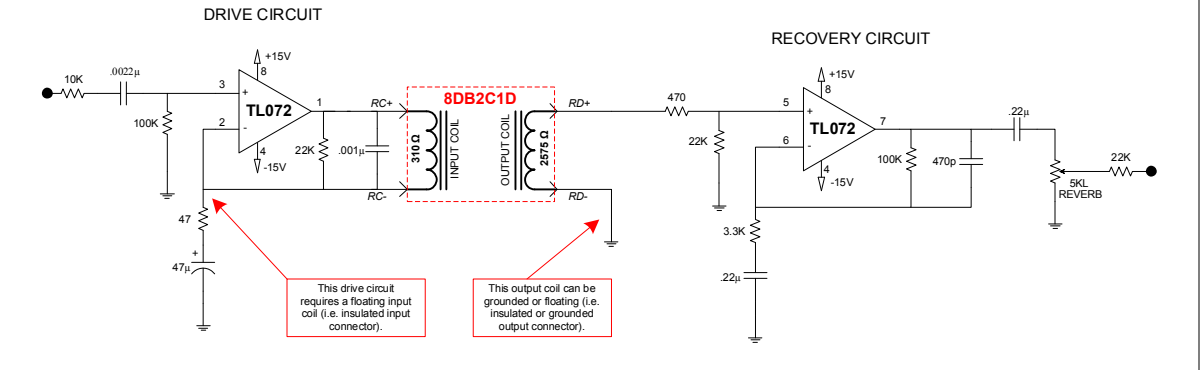

Drive Circuit Design Considerations: ³

- Use an input high-pass filter to compensate for the input coil's inductive reactance. It is recommended that the driver be a current or voltage source with an output rising 6 dB/octave with increasing frequency.
- Drive the input coil as hard as possible without overdriving (exceeding core saturation).
- Avoid DC currents through the coil for maximum headroom before core saturation.

In general, a current source is equivalent to a voltage source with a resistor in series.

In practice, the resistor should have a value greater than 5 times the 1kHz impedance of the input transducer.

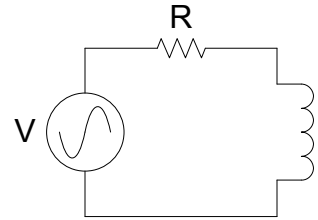

The voltage required will be: $V_{\max} = I_{\max} |R + Z|$

Recovery Circuit Design Considerations: ³

- The output signal from the tank should be about 1 to 5 mV. Use a preamp circuit with flat frequency response for recovery.
- The recovery circuit's input impedance should be high enough to prevent roll-off due to the output coil's inductive reactance. For example, the 10,000 Ω at 1kHz coil appears as a 60,000 Ω source at 6kHz.
- Use an output high-pass filter with a 50 Hz to 100 Hz cutoff to lessen the effects of rumble when the unit is mechanically shocked.

Accutronics® Part Numbering System

Vintage Accutronics® part numbers consist of a seven character alpha-numeric code with each character of the part number representing a specification.

CHARACTER	SPECIFICATION
1ST	TANK TYPE (Tank Length and Number of Transmission Springs)
2ND	INPUT IMPEDANCE (Measured at 1kHz)
3RD	OUTPUT IMPEDANCE (Measured at 1kHz)
4TH	DECAY TIME (Short, Medium or Long)
5TH	CONNECTORS (Insulated / Non-Insulated Configuration)
6TH	LOCKING DEVICES
7TH	MOUNTING PLANE (Transducer Magnet Adjustment)

ACCUTRONICS® (USA & KOREA) AND MOD™ REVERB TANK PART NUMBERING SYSTEM

Accutronics® part numbers consist of a seven character alpha-numeric code with each character of the part number representing a specification (For example, 4AB3C1B). MOD™ tanks add "MOD" in front of the part number (MOD-4AB3C1B).

TANK TYPE (Length & Number of Transmission Springs)

1	Short tank (9.25") with 2 transmission springs	8	Short tank (9.25") with 3 transmission springs
4	Long tank (16.75") with 2 transmission springs	9	Long tank (16.75") with 3 transmission springs

TYPE 1 & 4: INPUT IMPEDANCE (@ 1 kHz)

A	8 Ω	1.0 Ω*
B	150 Ω	25 Ω*
C	200 Ω	30 Ω*
D	250 Ω	35 Ω*
E	600 Ω	60 Ω*
F	1,475 Ω	200 Ω*

TYPE 8 & 9: INPUT IMPEDANCE (@ 1 kHz)

A	10 Ω
B	190 Ω
C	240 Ω
D	310 Ω
E	800 Ω
F	1,925 Ω

* Approximate DC resistance of transducer coils can be used as a reference for input and output impedance if the original reverb tank is not labeled. The actual resistance measured may vary.

TYPE 1 & 4: OUTPUT IMPEDANCE (@ 1 kHz)

A	500 Ω	40 Ω*
B	2,250 Ω	215 Ω*
C	10,000 Ω	800 Ω*

TYPE 8 & 9: OUTPUT IMPEDANCE (@ 1 kHz)

A	600 Ω
B	2,575 Ω
C	12,000 Ω

DECAY TIME

1	SHORT	(1.2 to 2.0 s)
2	MEDIUM	(1.75 to 3.0 s)
3	LONG	(2.75 to 4.0 s)

CONNECTORS (Non-Insulated or Insulated from Outer Channel)

GROUNDED = 0
 INSULATED = 1

	INPUT	OUTPUT	
A	0	0	
B	0	1	
C	1	0	
D	1	1	E = No Outer Channel

LOCKING DEVICES

1 = NO LOCK

MOUNTING PLANE (Predetermined Factory Adjustment of Transducer Magnets)

HORIZONTAL (Least Desirable*)

A = OPEN SIDE UP

B = OPEN SIDE DOWN

VERTICAL (Best*)

C = CONNECTORS UP

D = CONNECTORS DOWN

ON-END (Next Best*)

E = INPUT UP

F = OUTPUT UP

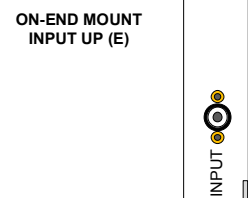
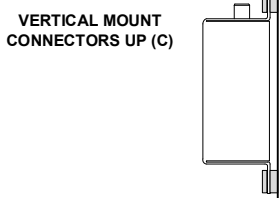
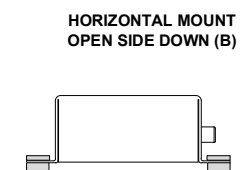

*The ideal mounting plane for reverb tanks is one that allows the weight of the transmission springs to keep the transducer magnets centered along the air gap and not toward the lamination.

BELTON REVERB TANK PART NUMBERING SYSTEM

Belton reverb tank part numbers have a slightly different numbering system than the Accutronics® numbering system (For example, BL2AB3C1B).

Company Identification

B Abbreviation for BELTON

Size

M	MINI	Outer Channel Length = 5.91"
S	SMALL	Outer Channel Length = 9.25"
L	LONG	Outer Channel Length = 16.75"

Number of Transmission Springs

2 two transmission springs	3 three transmission springs
-----------------------------------	-------------------------------------

2 SPRING: INPUT IMPEDANCE (@ 1 kHz)

3 SPRING: INPUT IMPEDANCE (@ 1 kHz)

A 8 Ω	0.9 Ω*	A 10 Ω
B 150 Ω	26 Ω*	B 190 Ω
C 200 Ω	27 Ω*	C 240 Ω
D 250 Ω	36 Ω*	D 310 Ω
E 600 Ω	75 Ω*	E 800 Ω
F 1,475 Ω	200 Ω*	F 1,925 Ω

* Approximate DC resistance of transducer coils can be used as a reference for input and output impedance if the original reverb tank is not labeled. The actual resistance measured may vary.

2 SPRING: OUTPUT IMPEDANCE (@ 1 kHz)

3 SPRING: OUTPUT IMPEDANCE (@ 1 kHz)

A 500 Ω	42 Ω*	A 600 Ω
B 2,250 Ω	200 Ω*	B 2,575 Ω
C 4,000 Ω	350 Ω*	C 4,000 Ω
D 10,000 Ω		D 12,000 Ω

All Other Specifications

SAME AS ACCUTRONICS®

A Comparison of Reverb Tank Brands

For many years, Accutronics® (a Hammond® Corporation Company) designed and built spring reverberation units in the United States. Today, most reverb tanks are built in Korea and China. The following is a comparison of current made reverb tanks, as well as the Accutronics® (made in USA) tanks which are no longer in production.

Physical Comparison:

Accutronics® (USA) – no longer in production

These tanks are the industry standard. They were marked as made in the USA.

- unpainted steel chassis
- panel mount phono jacks riveted to outer channel
- phono jack shell is grounded to reverb tank outer channel by surface to surface contact
- 3 spring units have all transmission springs laid out in one single plane
- phono jack terminals connect to transducer coils via small two pin plug connector

Accutronics® (Korea)

Accutronics® was purchased by Belton. These tanks are currently made in Korea with Accutronics® equipment.

- black painted steel chassis
- panel mount hooded phono jacks clamped into outer channel via plastic housing
- phono jack shell is grounded to reverb tank outer channel by a tab and self tapping screw driven into the chassis
- 3 spring units have all transmission springs laid out in one single plane
- phono jack terminals connect to transducer coils via small two pin plug connector

MOD™

Is a trademark of CE Distribution (USA). These tanks are currently made in China to vintage Accutronics® specs.

- black painted steel chassis
- PC mount phono jacks riveted to outer channel
- phono jack shell is grounded to reverb tank outer channel by two PCB copper pads and their soldered connection
- 3 spring units have transmission springs laid out in two planes
- phono jack terminals connect to transducer coils via direct wire taps

Belton (Korea)

Belton is a Korean electronic components company that also makes the Digi-Log Reverb Module.

- gray painted steel chassis
- panel mount hooded phono jacks clamped into outer channel via plastic housing
- phono jack shell is grounded to reverb tank outer channel by a tab and self tapping screw driven into the chassis
- 3 spring units have transmission springs laid out in two planes
- phono jack terminals connect to transducer coils via direct wire taps

Sound Characteristic Comparison:

Here is a comparison between the four different reverb tank brands discussed previously. In comparing the sound characteristics of reverb tanks it is important to remember that the amplifier plays a major role in how the reverberation effect will sound. (i.e. The same reverb tank will sound different depending on the amp).

As was discussed in detail on p. 3, the reverberation effect can be thought of as being composed of two parts:

- 1) Early reflections – shape the listener’s conception of room size
- 2) Cluttered reflections – convey the liveliness of a room

In this comparison we have created two categories to compare the early reflections and cluttered decaying reflections of each tank. The same guitar (Mexican Fender® Stratocaster®) and amp (Mesa Boogie® Mark II-C®) were used with each tank. A solid chord chop was played as the easiest way to compare these two characteristics.

“**Echo**” is used to describe the initial reflections. The first reflections arrive about as quickly as the blink of an eye, but they can be heard as being “**pronounced**”, “**moderate**” or “**subtle**”.

“**Flutter**” is used to describe the cluttered reflections while they decay over the matter of a few seconds. As the cluttered waves blend into one another a fluttering sound can be heard as “**rapid**”, “**moderate**” or “**slow**”.

COMPARISON OF 9AB3C1B REVERB TANKS CONNECTED TO THE SAME MESA BOOGIE® MARK II-C® GUITAR AMP

	Echo (early reflections)	Flutter (cluttered reflections)	Guitarist Description (Overall)
Accutronics® (USA) <i>No longer in production</i>	Pronounced	Rapid, Most emphasis on highs	Focused, bright and mellow wetness.
Accutronics® (Korea)	Subtle	Rapid, Emphasis on lows & mids	Thick, with lots of wet bite and mid attack.
MOD™	Pronounced	Rapid, Emphasis on mids & highs	Focused, lots of wet shimmer and bite.
Belton (Korea)	Moderate	Slow, Most emphasis on lows & mids	Straightforward with lots of wet bite.

Three Springs vs. Two Springs:

Any amp using a two spring tank may have its tank replaced by a three spring tank of the same impedance code (for example, 4AB3C1B vs. 9AB3C1B) and vice versa. This will also change the sound characteristics of the reverberation effect. Three spring tanks have a more smoothed out flutter with a bigger, fuller sounding reverb effect and more lows. Two spring tanks have more flutter and grit, they also seem to capture that vintage 1960's vibe better.

Written by Kurt Prange

Kurt Prange (BSEE) is the Sales Engineer for Amplified Parts in Tempe, AZ (amplifiedparts.com). Kurt began playing guitar at the age of nine in Kalamazoo, MI. He is a guitar DIY'er and tube amp designer who enjoys helping other musicians along in the endless pursuit of tone.