

2W Electric Guitar Amplifier

- Class A Single Ended Pentode Output
- 12AX7 Small Signal Dual Triode Pre-Amp
- 12L8GT Dual Power Pentode Output
- Designed & Drawn by Petter Blix

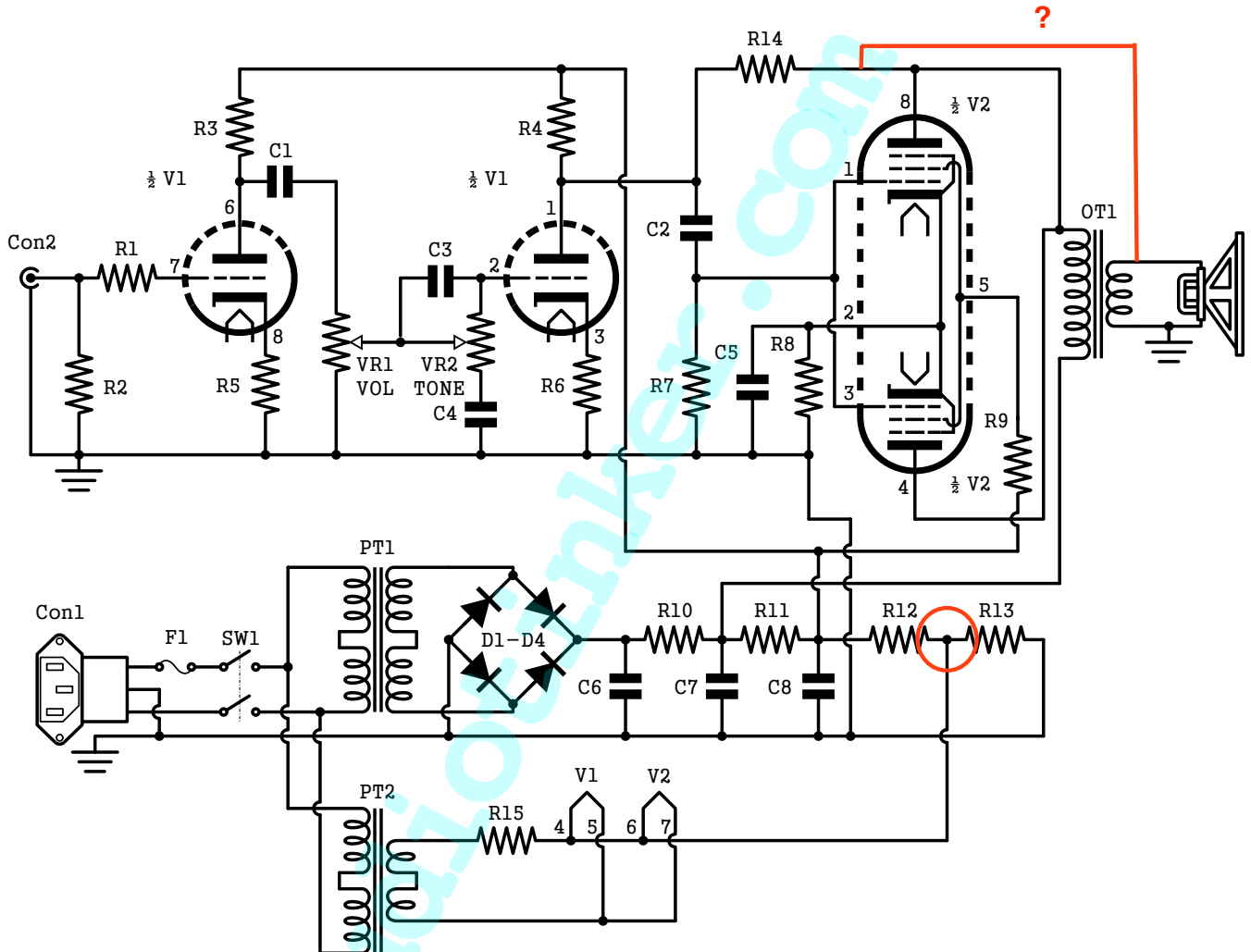

C1, C2	.02uF/450V	PT1	120VCT @ 100mA
C3	470pF/450V	PT2	12.6VCT @ 300mA
C4	4700pF/450V	OT1	5K : 8Ω, SINGLE ENDED
C5	10uF/10V	V1	12AX7/ECC83
C6	10uF/250V	V2	12L8GT
C7, C8	100uF/250V	F1	FUSE, 1A
D1-D4	1N4007	SW1	POWER SWITCH
R1	47k	Con1	IEC POWER ENTRY/LINE FILTER
R2, R14	1M	Con2	1/4" PHONO RECEPTACLE
R3, R4	100k		
R5, R6	1k2		
R7	470k		
R8	270Ω, 5W		
R9	1k, CC		
R10, R11	150Ω, 5W		
R12, R13	120k, CC		
R15	7.5Ω, 5W		
VR1, VR2	1M, Audio Taper		