

Fig. 1. Front view of "universal vibrato" unit showing location of above-chassis parts and the various controls on the chassis apron.



THE UNIVERSAL Vibrato

By
RICHARD H. DORF
Audio Consultant

A phase modulator circuit which can be used with guitars, organs, pianos, etc., to produce a realistic vibrato effect.

IN THE course of a great deal of investigation into the electronic production and control of music and publication of the results, the writer has received quite a number of requests for a vibrato circuit from guitarists and others. Until recently the only circuit capable of imparting vibrato to music originating from fixed-frequency sources was the elaborate electro-mechanical scanner used in some *Hammond* organs, and it is impractical for individuals to construct. Now, however, an entirely practical, easily constructed all-electronic circuit does exist. The writer has employed it in somewhat modified form in the "universal vibrato," a completely self-contained device.

Either vibrato or tremolo is an important factor in music of almost every kind. To note its effect, hum a single tone, keeping the pitch perfectly constant as far as possible. Whether you are a crow-voiced musical duffer or a Metropolitan tenor, you will note that the tone is musically uninteresting. Now listen to a professional singer on the radio or from a record and note that when he sings a single tone he does *not* keep the pitch or frequency constant. He varies it up and down slightly at a rate somewhere between about 5 and 8 cycles-per-second. This pitch variation is known as "vibrato." It makes a tone interesting.

The violinist or other stringed-instrument player does the same thing by moving the finger with which he is pressing down a string. This varies the effective length of the string between 5 and 8 times per second and gives the vibrato frequency variation. Everyone who has seen a violinist play remembers that the left hand is always in

vibratory motion; it is kept so to produce vibrato.

A few instruments have tone sources whose pitch cannot be varied. One of these is the pipe organ, whose pitch depends on the dimensions of the pipes. Another is the harmonica, whose pitch depends on the dimensions and mass of the reeds. In those instruments vibrato is impossible and the substitute is tremolo. Tremolo is a periodic variation in volume. In the organ it is produced by alternately blocking and unblocking the orifice in the chamber containing the pipes by mechanical means. In the harmonica tremolo can be produced by the vibratory movement of a hand at the rear of the instrument, closing and opening a path between the reeds and the outer air.

Players of instruments capable of vibrato must be fairly skillful to produce it. Many amateur guitarists do not have that skill. They employ contact microphones and amplifiers to give their instruments Hawaiian guitar effects. To provide the desired periodic variation some of these amplifiers contain tremolo circuits. Such circuits consist of a low-frequency oscillator, the output of which varies the gain of an amplifier stage at the oscillator frequency.

Fig. 2. The "Doppler effect" applied to the "universal vibrato" circuit. See text.

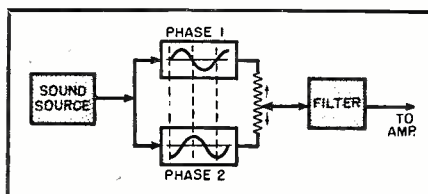

Unfortunately, however, tremolo—volume variation—is not nearly as pleasing as vibrato—frequency variation. But while it is easy to vary the volume of music, it is not as easy to vary its pitch electrically.

The "universal vibrato" does this seemingly impossible job. It can take music from any source whatever—any instrument, from a contact microphone, radio, records, tape—and vary its pitch up and down at a rate 5 to 8 times per second to produce the same effect as if the player had himself produced the vibrato. This means not only that the guitar player can have vibrato without working at it, but also that other instrumentalists can do the same. Of equal interest is the fact that instruments on which vibrato cannot be produced at all—pipe and reed organs, some *Hammond* organs, piano, etc.—can now have it, and some very interesting new effects are possible.

How It Works

The "universal vibrato" is a phase modulator. Its principle has been thought of before, but an embodiment of it was recently designed in detail and brought out commercially in a spinet electronic organ made by *Wurlitzer*, the Model 44. This organ has reeds as tone sources. The designers were dissatisfied with the tremolo which was produced by rotating vanes in front of the speaker on previous models and designed this circuit to provide a genuine tremolo.

To visualize how the principle works, remember the old illustration of the Doppler effect. A train is approaching you, blowing its whistle. As the train gets closer the pitch of the whistle seems to rise, reaching a maximum as the train reaches you. Then, as the train goes away the whistle pitch descends again.

The vibrato is like the moving train whistle. But instead of approaching and passing the listener, it travels on a reciprocating path—moving forward

and backward, approaching, backing away, approaching, and backing away. Thus we hear the whistle pitch rise and fall, rise and fall. All this despite the fact that the whistle itself—steam blown against a mechanical whistle device—really remains at quite constant pitch as far as the train engineer (who remains at a constant distance from it) is concerned.

What is really happening, from the viewpoint of the trackside listener, is phase modulation. If the train remains a constant distance away, the pitch is constant. It takes a certain amount of time for the sound to reach the listener's ears; and all parts of the wave take the same amount of time, so that the ear hears each part of the wave in the proper order and with the same time separation as at the source.

When the train is moving toward the listener, however, that is not true. As the train gets nearer, the time required for the sound to get to the ear constantly decreases. As a result, the second half of the wave, for instance, gets to the listener before it ought to. And since the two parts of the wave are closer together at the ear than at the whistle, the ear assumes that the frequency is higher.

This Doppler effect is simply a case of advancing phase. The principle is used commonly in phase-modulated r.f. transmitters to produce frequency modulation. And this is exactly what happens in the "universal vibrato."

The idea is block-diagrammed in Fig. 2. The sound source, whatever it may be, is converted to audio by a microphone, tuner, pickup, or whatever it may be. From it two separate audio signals are derived. Each signal is an exact replica of the original, but they are displaced from each other in phase by approximately 90 degrees. In Fig. 2 phase 2 lags phase 1.

The two phase-displaced signals are connected (for illustration purposes only) by a potentiometer. The arm of the potentiometer is constantly moving up and down 5 to 8 times per second. At each end of the potentiometer the arm picks up maximum signal from one phase and minimum from the other. At medium positions it picks up a proportional amount of each. Thus the signal on the potentiometer arm is constantly varying in phase. As it travels toward the phase-1 signal, the signal it picks up is advancing in phase and the frequency apparently rises; as it moves toward phase 2, the phase is retarded and the frequency decreases.

Note that if the arm stops in a single position, the frequency remains constant. The two signals simply mix at the arm and produce a single signal and with a phase which is the resultant of the two, according to the proportion in which they are mixed. Since the ear is not sensitive to phase as such, the result, amplified and radiated from a loudspeaker, will sound just like any ordinary signal.

The faster the arm travels up and
(Continued on page 90)

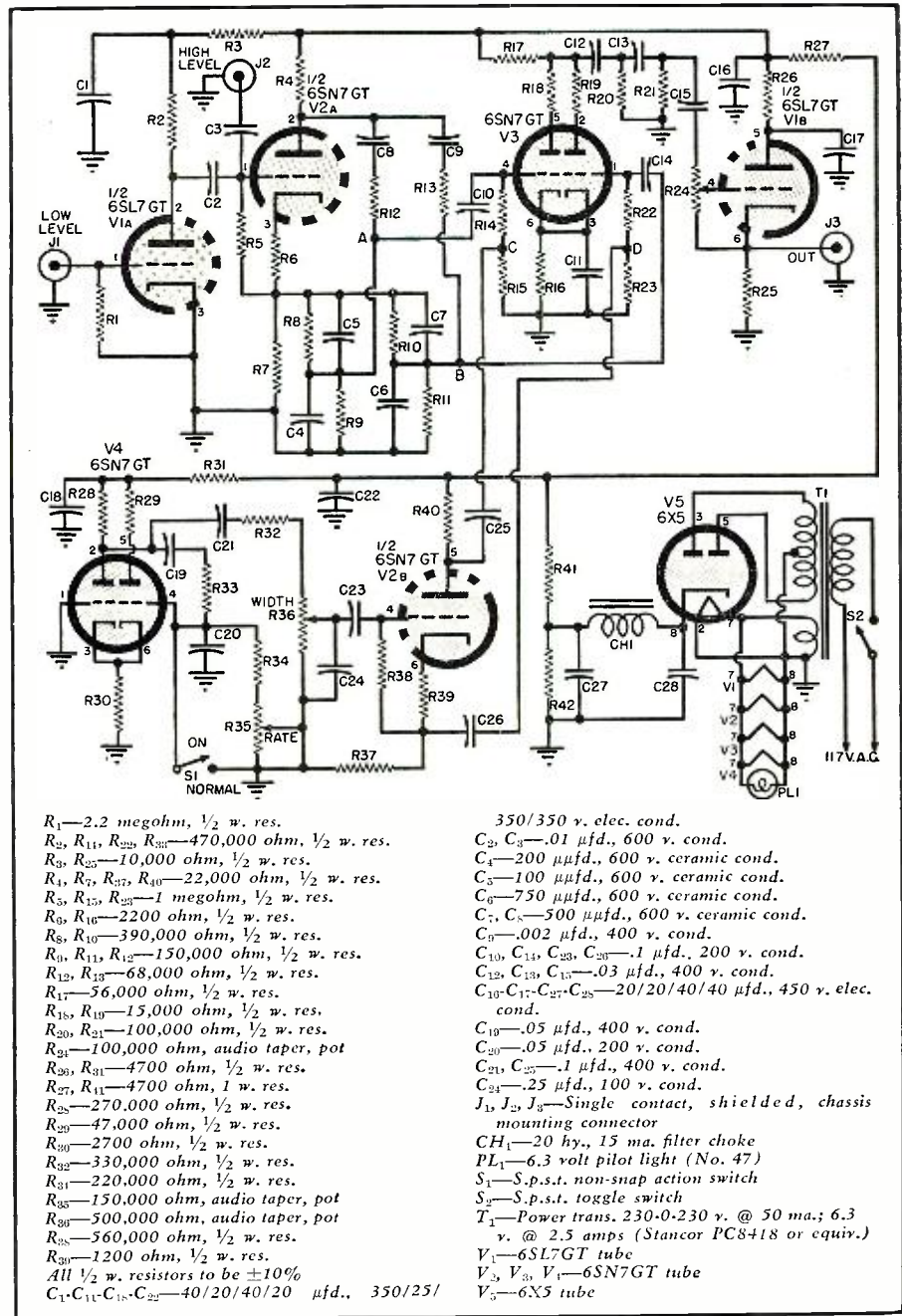
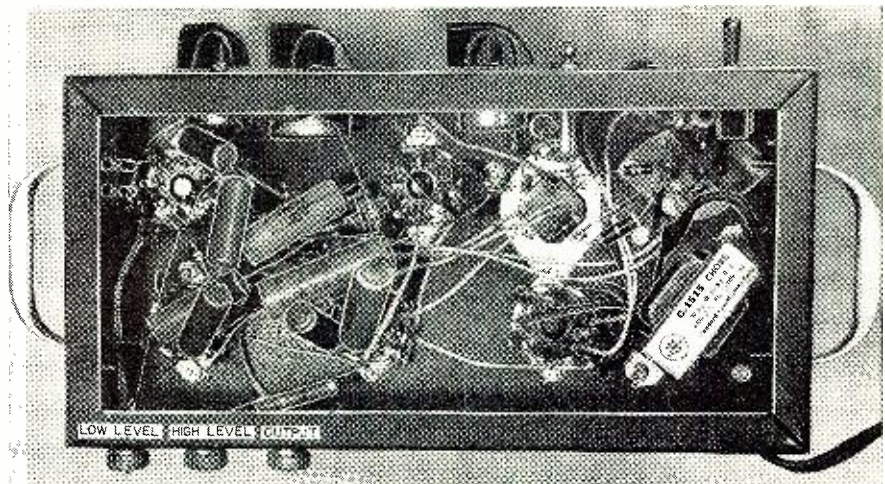
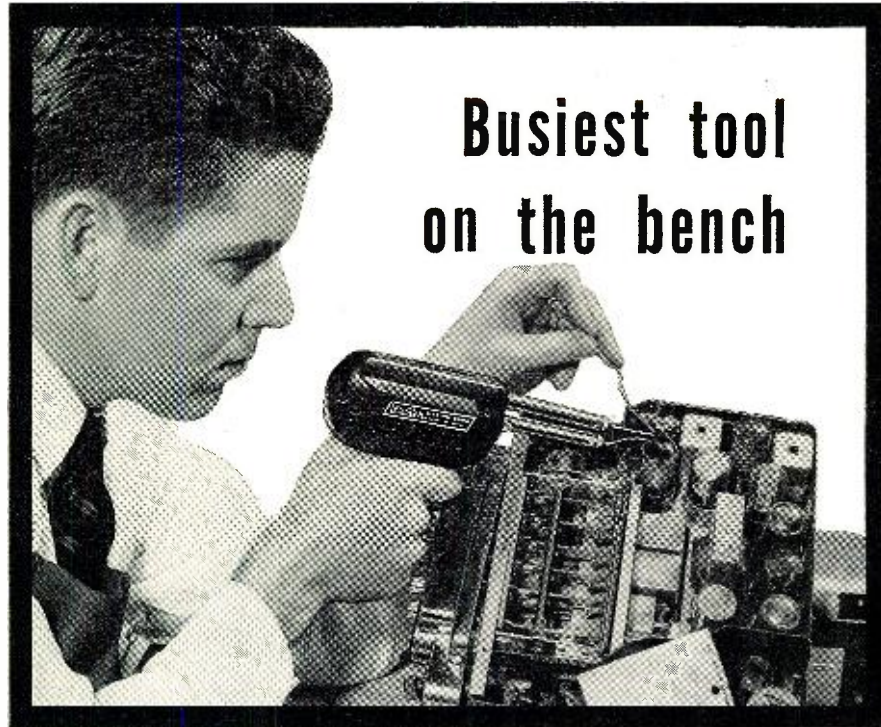

Fig. 3. Complete schematic diagram of the "universal vibrato" unit.

Fig. 4. Underchassis view. A smaller chassis may be used if desired.





Busiest tool on the bench

**The new Weller Soldering Gun—the tool that finishes
the job before ordinary soldering tools warm up!**

Weller's newest models—

Go anywhere inside circuit-jammed chassis of smallest portables and table models. Slim streamlining and longer reach makes tight spots a cinch—in a fraction of the normal time.

Get hot instantly with click of trigger. Another click and—power is instantly boosted—up to 275 watts!

Give wide selection of power for every job—100, 135, 200, 250, and now—275 watts! Light and heavy duty models, either single or dual heats.

You'll like the perfect balance and slim lines, too—on all latest Weller models. Ask your distributor for a demonstration, or write direct for bulletin.

Weller

**Better from Grip to Tip
SOLDERING GUNS**

810 Packer Street, Easton, Pa.

**... FIRST CHOICE with
servicemen because
Fenwire is BEST by TEST**

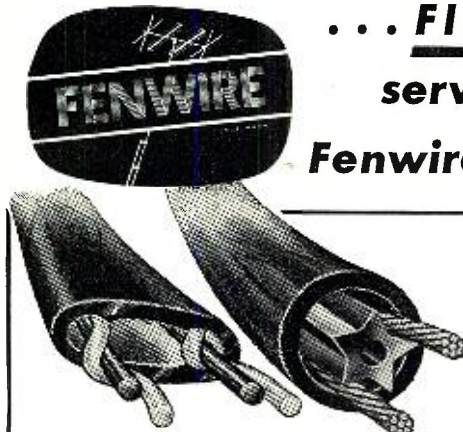

*FENTUBE-AIRSPACED and *TWISTUBE are outstanding for high performance—low loss—stable characteristics under all atmospheric conditions—reduced interference pick up—reasonable price.

Write Dept. RN-4 for literature on complete FENWIRE line including "TUF-GUY" . . . finest guywire made.

(Sold through jobbers only.)

*U.S. & British Pat. Pending

FENTON COMPANY • 15 Moore Street, N. Y. 4, N. Y. Tel. Bowling Green 9-3445

The Vibrato

(Continued from page 53)

down the higher will be the rate of frequency change. (Also, to a minor extent in practice, the greater will be the apparent total frequency variation.) If the arm travels all the way to the ends of the pot the frequency will vary to its greatest extent; but if it moves only a little way each side of center the amount of frequency change will be small. Obviously then, the vibrato rate and width (or depth) can both be controlled.

The filter which follows the potentiometer is there to remove the frequency component representing the movement of the pot arm itself, which is below 10 cycles.

Electronic Circuits

In the actual device there are no moving parts; the whole job is done by invisible electrons. The entire circuit is diagrammed in Fig. 3.

In the "universal vibrato" pre- and post-amplification have been added to the vibrato circuit itself to make it more versatile. V_{3A} is a preamplifier for low-level inputs. The high-level input is satisfactory for most purposes. When it is used with the volume control at maximum the device has approximately unity gain, and the output voltage is practically identical to the input. V_{1B} is the output amplifier, a cathode-follower, allowing a long line to the main amplifier.

The first tube of the vibrato circuit itself is V_{2A} , the phase splitter. It looks like an ordinary "long-tailed" phase splitter, with equal loads in cathode and plate circuits to produce two outputs 180 degrees apart. And this is just what it is.

The requirement for the vibrato circuit is to obtain two voltages which are about 90 degrees apart at all frequencies. Phase-shifting circuits are quite common, but the amount of phase shift, as well as the amplitude of the output, in any single circuit is entirely dependent on frequency. To make the phase separation fairly independent of frequency it is possible to take two voltages 180 degrees apart and pass them through phase-shift networks so designed that as one signal shifts in phase due to frequency the other also shifts in such a manner as to keep the angle between the two at about 90 degrees. The angle of either changes with frequency with respect to the original signal entering the phase splitter. But this does not matter as long as we can derive two signals whose separation in phase remains constant. An article, "Phase Angle Measurements at A.F.", in the *Radio-Electronic Engineering* Edition of this magazine for July, 1953, explains this in detail and gives the calculations, though for a different purpose.

In Fig 3 the result is produced by the networks R_8-C_5 , C_4-R_9 , $R_{10}-C_7$, C_6-R_{11} , C_5-R_{12} , and C_8-R_{13} . The two signals

RADIO & TELEVISION NEWS

**HUDSON RADIO & TELEVISION
CORP.**

48 W 48th ST., NEW YORK 36, N. Y.
212 FULTON ST., NEW YORK 7, N. Y.
35 WILLIAM ST., NEWARK 2, N. J.

by itself

IN A CLASS

NC-98 \$149⁹⁵

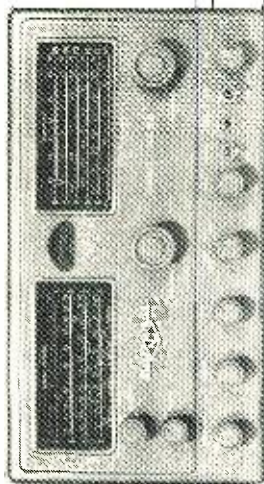

National



THE NEW

present at points *A* and *B* are sufficiently close to 90 degrees apart at all audio frequencies to give the needed result.

Each of these signals is fed through a 0.1- μ fd. blocking condenser to one grid of V_3 . The plates of V_3 are connected through separate 15,000-ohm resistors (for isolation) to a common load resistor R_{17} . At this point, assuming the tube operates normally, we would have a single signal of the same waveshape as the input with phase halfway between those of the signals at *A* and *B*.

The tube is actually operating as an electronic switch, however. To points *C* and *D* is connected a locally generated signal of a frequency between 5 and 8 cycles. When this signal makes point *C* most negative and point *D* most positive, the left triode of V_3 is cut off and the right triode has maximum gain; the reverse is true as well. Thus at one time the signal from point *A* appears at the output and at another the signal from point *B* appears. This means that the output of V_3 is constantly changing in phase, which will appear as a constant change in frequency. We have thus frequency-modulated the audio input signal and imparted a genuine vibrato to it.

The network C_{12} - C_{13} - C_{15} - R_{20} - R_{21} - R_{24} is a high-pass filter, of which R_{24} also acts as a volume control. The filter prevents the switching action of V_3 from appearing in the output as amplitude modulation of the signal. Some AM may appear but it contributes to the pleasantness of the effect. The filter also reduces the low-frequency response of the system somewhat, but this is unimportant for most musical instruments, which do not generate tones low enough to be affected. If necessary a sharp-cut-off LC filter can be substituted, tuning for a cut-off just below the lowest musical note to be passed.

The switching signal is generated by V_1 , which is a simple RC sub-audio oscillator. The frequency is determined by C_{19} , R_{23} , C_{20} , and the series value of R_{21} and R_{23} . R_{23} is the vibrato rate control which varies the oscillator frequency to determine how fast the vibrato should be. S_1 stops oscillation when it is closed, removing the vibrato.

The oscillator output is carried through C_{21} and R_{22} to a potentiometer R_{26} . The arm of this pot goes to the grid of V_{2B} , the vibrato phase splitter. R_{26} is the width control, which determines how much frequency change there will be on each vibrato cycle.

While V_{2B} is a phase splitter of the same type as V_{2A} , no further phase-shifting networks are added. The two 180-degree-separated low-frequency signals are fed to the two grids of V_3 in push-pull as the switching signals.

Construction

In the case of this particular gadget it is impossible to claim that the neatest possible layout was made.

AIREX'S HI-FIDELITY 1954 CO-CHANNEL 630FA-2A GENUINE FM ARMSTRONG SOUND SYSTEM READY FOR COLOR CONVERTER

**3 MONTHS
RMA
GUAR.
ON ALL
PARTS**

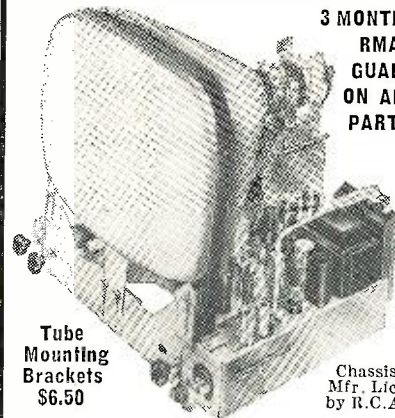

Tube
Mounting
Brackets
\$6.50

Chassis
Mfr. Lic.
by R.C.A.

CHECK THESE EXCLUSIVE FEATURES

- 10 WATT push-pull audio output. Frequency range from 40 to 12,000 cycles • 3 position fringe area switch • Delayed gated AGC system • Standard Coil Cascade Tuner prevents radiation • Retrace Blanking Circuit allows you to raise the brightness without the annoying vertical retrace lines • Heavy duty front focus control • Automatic gain control potentiometer allows you to adjust the threshold sensitivity as low as 4 microvolts & still keep the full 4 MC band width • Improved sync amplifier • Improved automatic brightness control • Set aligned for 21.9 MC. New Ham band will not interfere • Improved fused high voltage power supply gives full 14.5 KV under load. Will handle all picture tubes up to 24 inch round with full sweep • Improved video amplifier has a gain of 40 • All moulded plastic condensers give long life & trouble-free operation • Easily adapted to new UHF stations in 2 minutes by just changing a strip in the tuner • Extra heavy duty power transformer with large safety factor • 6CB6 tubes in Video IF to give full gain • Extra filtering in power supply for hum & ripple-free operation • Phono Connection & switch on chassis allows you to play your phonograph or tuner through the built-in 10 watt hi-fidelity amplifier • Extra heavy duty focus coil, which runs cool • Full focus cosine yoke.

THE ONLY CHASSIS WITH 10 WATT PUSH-PULL HI-FI AUDIO SYSTEM AT

\$169⁹⁵

Fed. Tax Included Less C.R. Tube and Brackets

Complete with Two Speakers—12" Hi-Fi
Woofer and Tweeter

With UHF 83 Channel Converter—\$211.90
Detailed Service Manual & Schematic—\$1

COMBINATION SAVING!

• 630 FA-2A Chassis
• 21" Picture Tube
• Mah. Console Cabinet
With mask, glass, tube mtg brackets FOR THE 3 UNITS

This Month
Only
\$244⁹⁵
Fed. Tax
Incl.

TV PICTURE TUBE SALE

Standard Brands, Factory
New, Guar. 1 year.

- 17" Tube...\$27.95
- 20" Tube...\$34.95
- 21" Tube...\$39.95
- 24" Tube Round
(Guar. 6 Mos.)...\$79.95
- 24" Rect...\$59.95
- 27" Tube Rect...\$79.95
- Ring and Sleeve
for 24" Round...\$ 7.50

**630 CHASSIS
FOR 24" & 27" RECT.
OPERATION \$189⁹⁵**
PRICE
Not push pull audio

**TV GOLD
PLASTIC MASKS**

- 16" and 17" \$ 4.95
- 20" and 21" \$ 7.95
- 24" \$14.95

630 UHF
converter . . . \$34.95

BARGAIN CABINET BUY

Beautiful mahogany console cabinet cut
for 630 FA-2A Chassis. Complete with
mask, glass & tube mounting brackets..

\$49.95

In Blond \$59.95

Send for complete cabinet brochure

FREE—New TV—Hi-Fi PARTS CATALOG

All merchandise brand new, factory fresh, guaranteed. Mail & phone orders filled upon receipt of certified check or money order for \$25 as deposit on TV chassis. 20% on other items. Balance C.O.D., F.O.B. factory N. Y. Prices & specifications subject to change without notice. NO FED. TAXES TO PAY.

AIREX RADIO CORP.

SHOWROOM: 171 Washington St., N. Y. 7
Gramercy 7-9245

Probably not enough time was spent figuring out on paper exactly what underchassis room had to be made available where. However, the model was not really too far off and readers can do a better job by noting where the crowding occurs and acting accordingly.

The basic unit is an "amplifier foundation" 10 1/4" long and 5" wide. The circuit could probably be built on a slightly smaller chassis but this size seems about the best. The chassis-cover "foundation" unit is more useful than a chassis-and-cabinet setup because all controls can be on the chassis apron without looking incongruous. Where there is a cabinet the controls ought to be on the front panel, which would require long leads coming through the chassis.

Fig. 1 shows the chassis top with the cover removed. At lower left is V_1 , with V_2 to its right. The tubes at the rear are, left to right, V_4 , V_3 , and V_5 . The underchassis view of Fig. 4 shows that the filter choke is mounted under the power transformer by two of the same screws that hold the transformer down. Switch S_1 , the vibrato "on-off" switch, is a surplus item taken from an SCR-274-N antenna junction box, but any kind can be used.

The reader with a vibrato requirement need not, of course, build his unit just as this one was designed. If it is convenient it can be built into an amplifier between any two stages that do not handle more than 10 volts of audio. In that case it can use the amplifier's power supply. The "B" requirements are only about 15 ma., although the existing filament transformer should be looked over to be sure that it will stand an additional 900 ma. drag required by the vibrato-circuit tubes, V_2 , V_3 , and V_4 in Fig. 3.

In using the "universal vibrato" with instruments which are primarily acoustic (where amplification need not be used or where the acoustic sound will be louder than the amplified sound) the way to add the vibrato is to make a recording, placing the vibrato between microphone and amplifier or between two amplifier stages. Instruments of this kind include pianos, pipe organs, and the like.

-30-

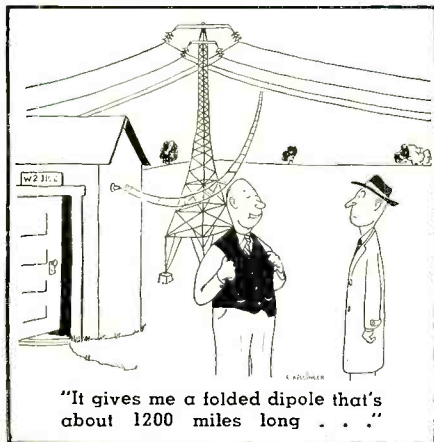

April, 1954

Here's how RCA INTERMATCHED COMPONENTS take the mystery out of High Fidelity

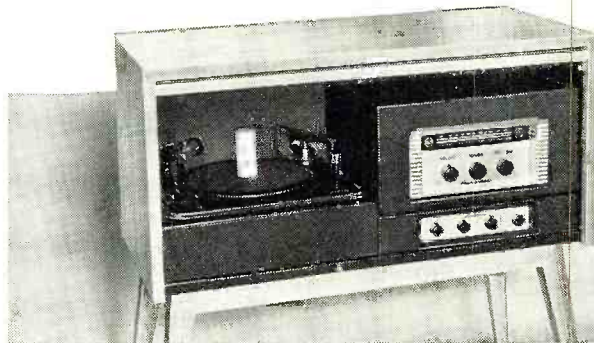

RCA Intermatched High-Fidelity cabinet and enclosures house any selection of components you may choose.

If you're interested in high fidelity . . . interested in the beauty of music, beautifully reproduced, but confused about how to select the system you want . . . here's how you can have everything you want in high fidelity *plus the assurance of the RCA name on every component in your system.*

Here is professional-grade equipment—bearing the best known name in professional sound—designed to bring the concert hall and the recording studio into your home. Here is RCA's broad background in acoustics and profes-

sional sound reproduction in equipment selected to meet your needs, your taste in high fidelity, and your budget.

In RCA's broad line you can find an almost limitless number of combinations—and the *one* combination you want. Because these units are all *intermatched*, you can develop your own system without a technical background—without fear of mismatch at any stage. It's the easy way to choose . . . it's the sure way to get what you want in high fidelity.

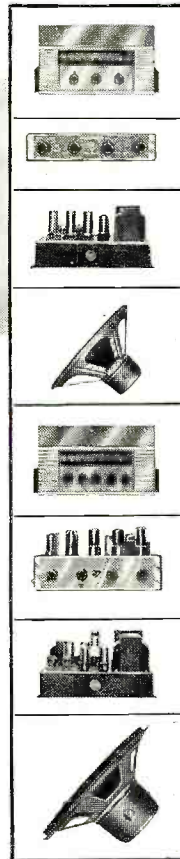

Work out any system you want—Select from these typical combinations—or plan your own

HEAR THEM AT YOUR RCA ELECTRONICS DISTRIBUTOR'S

	TUNERS		AMPLIFIERS			SPEAKERS				
	Record Changer (SRC-51)	Pre-Amplifier (SV-1)	ST-1	SVT-1	SVP-10 (10-watt)	SP-10 (DeLuxe 10-watt)	SP-20 (DeLuxe 20-watt)	SL-8	SL-12	LC-1A
Quality record reproduction at low cost	X				X			X		
Quality record and radio reproduction at low cost	X		X		X			X		
Extended range record reproduction, medium price	X	X				X			X	
Extended range record and radio reproduction, medium price	X			X		X			X	
DeLuxe quality record reproduction	X	X					X			X
DeLuxe quality record and radio reproduction	X			X			X			X

"Professional-Grade"
High Fidelity
from RCA—
LEADER IN SOUND



RADIO CORPORATION of AMERICA

RCA Engineering Products
Dept. B222, Building 15-1, Camden, N. J.

- Please send me your new, free booklet on RCA Intermatched high-fidelity equipment.
- Please send me information on the new complete RCA high-fidelity "Victrola"® phonographs.

Name _____
Address _____
City _____ Zone _____ State _____