

All caps 500VDC, unless noted

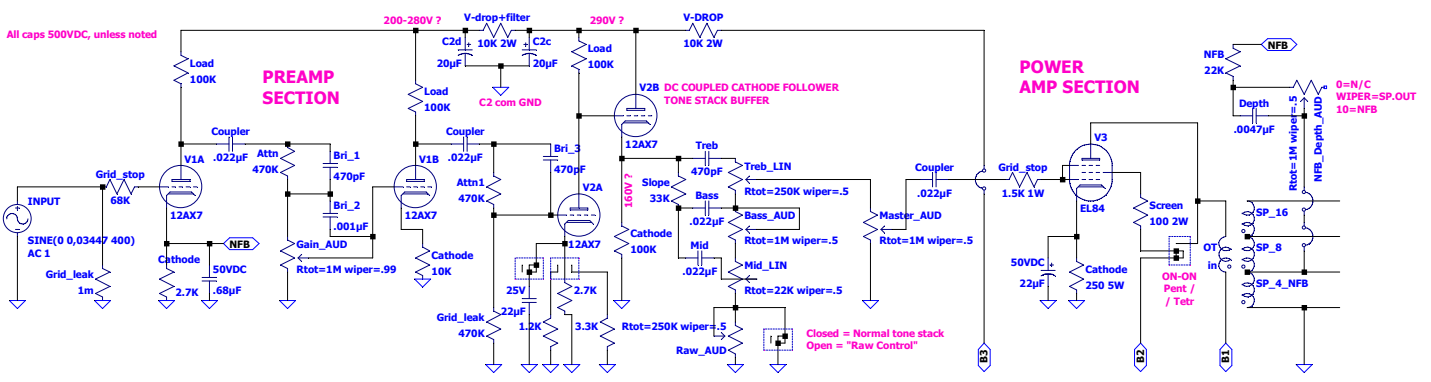

Check all B+, EL84 design max 300V.

