

OD Section

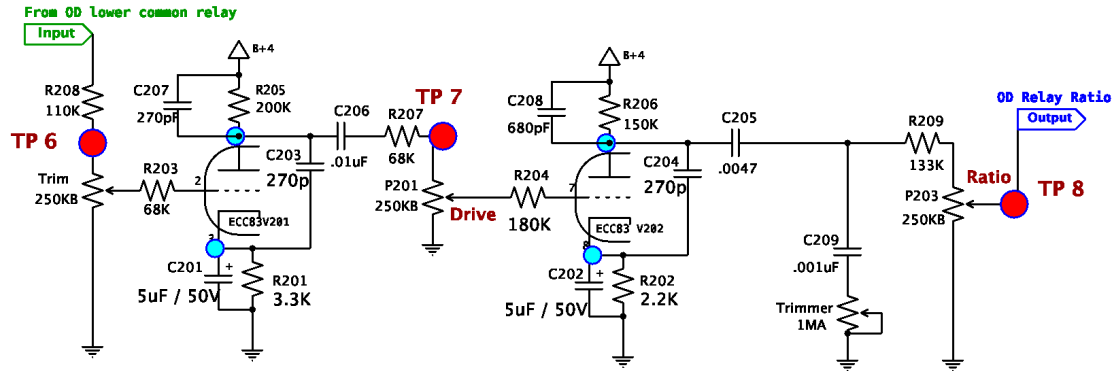

Tweed Bluezmeister

Based on DaGeezer and Tubenit versions

acheld

Rev 1.0
2025-02-26

Page # 1 of 2

From Preamp Output / OD Relay

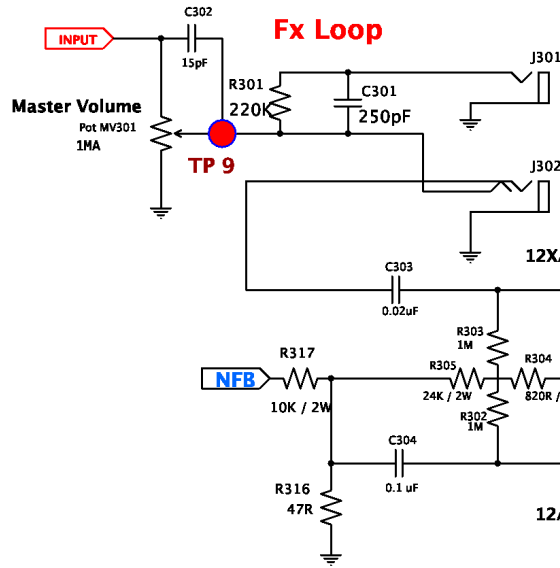

Fx Loop

Notes:

1. Consider 10k grid stoppers, R510 R311
2. Consider 0.1uF, C306 C307

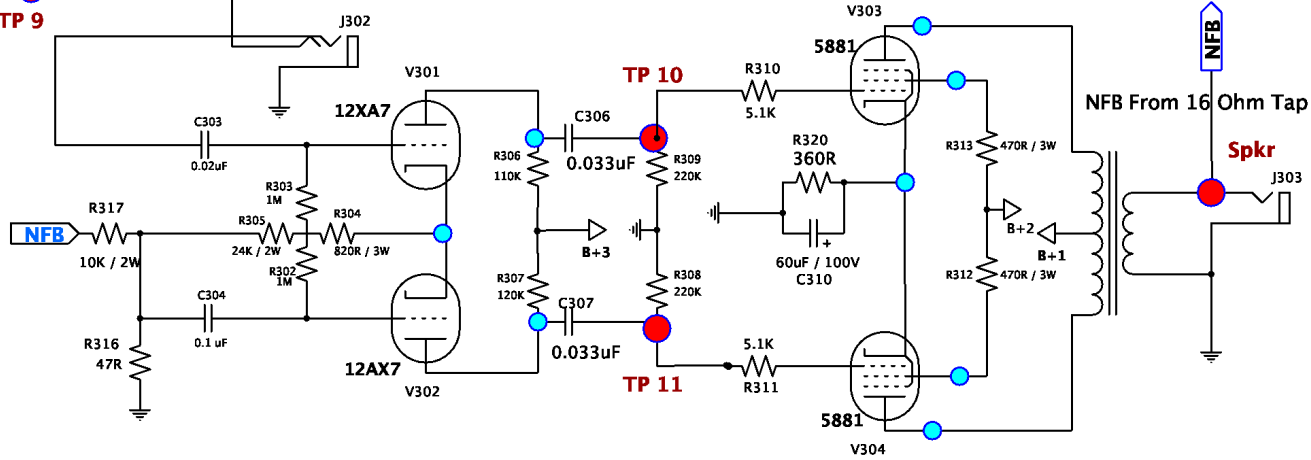

5 VDC Power Supply

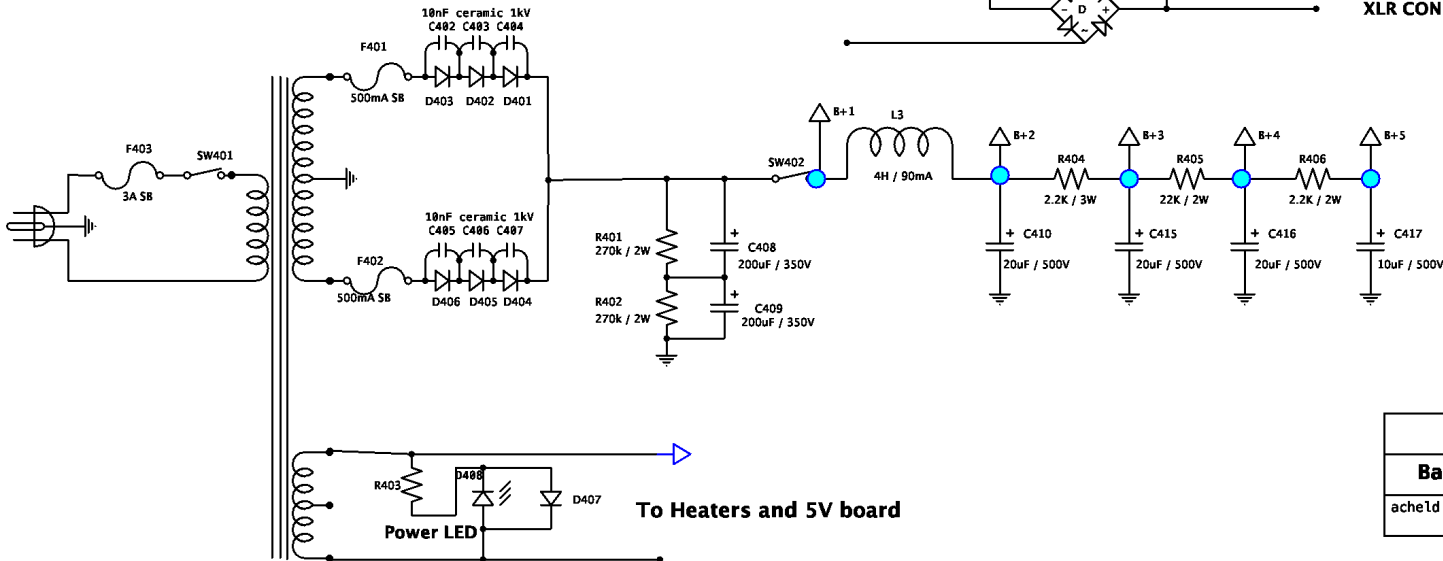
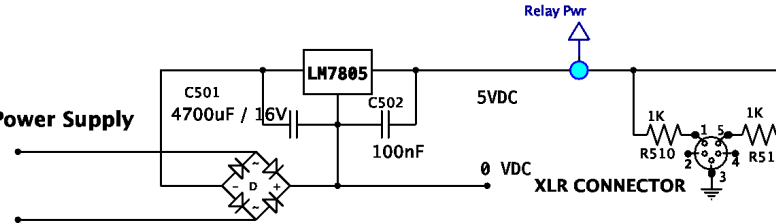

Iron:
 PT — Hammond 290CX
 Choke — Hammond 194B
 OT — Hammond 1760J

Tweed Bluezmeister		
Based on DaGeezer and Tubenit versions		
acheId	Rev 1.0 2025-02-26	Page # 2 of 2