

NOTE: IF THE HRM TONE STACK IS NOT REQUIRED:
 1) DO NOT POPULATE R22, R23, R24, C40A, C41, C42, TR3, TR4 AND TR5.
 2) POPULATE CAPACITOR C40B.

NOTE: IF THE HRM TONE STACK IS REQUIRED:
 1) DO NOT POPULATE C40B.

PT, No CT, Use D1, DO NOT USE D17, D18, D19 & D20
 PT, w/ CT, Use D17, D18, D19 & D20, DO NOT USE D1

All relays are C93402
 DO NOT SUBSTITUTE!

Title		HRD to ODS	
Size	C	Document Number	ODSBM2019
Date:	Saturday, September 14, 2024	Sheet	1 of 3
Rev	F2		

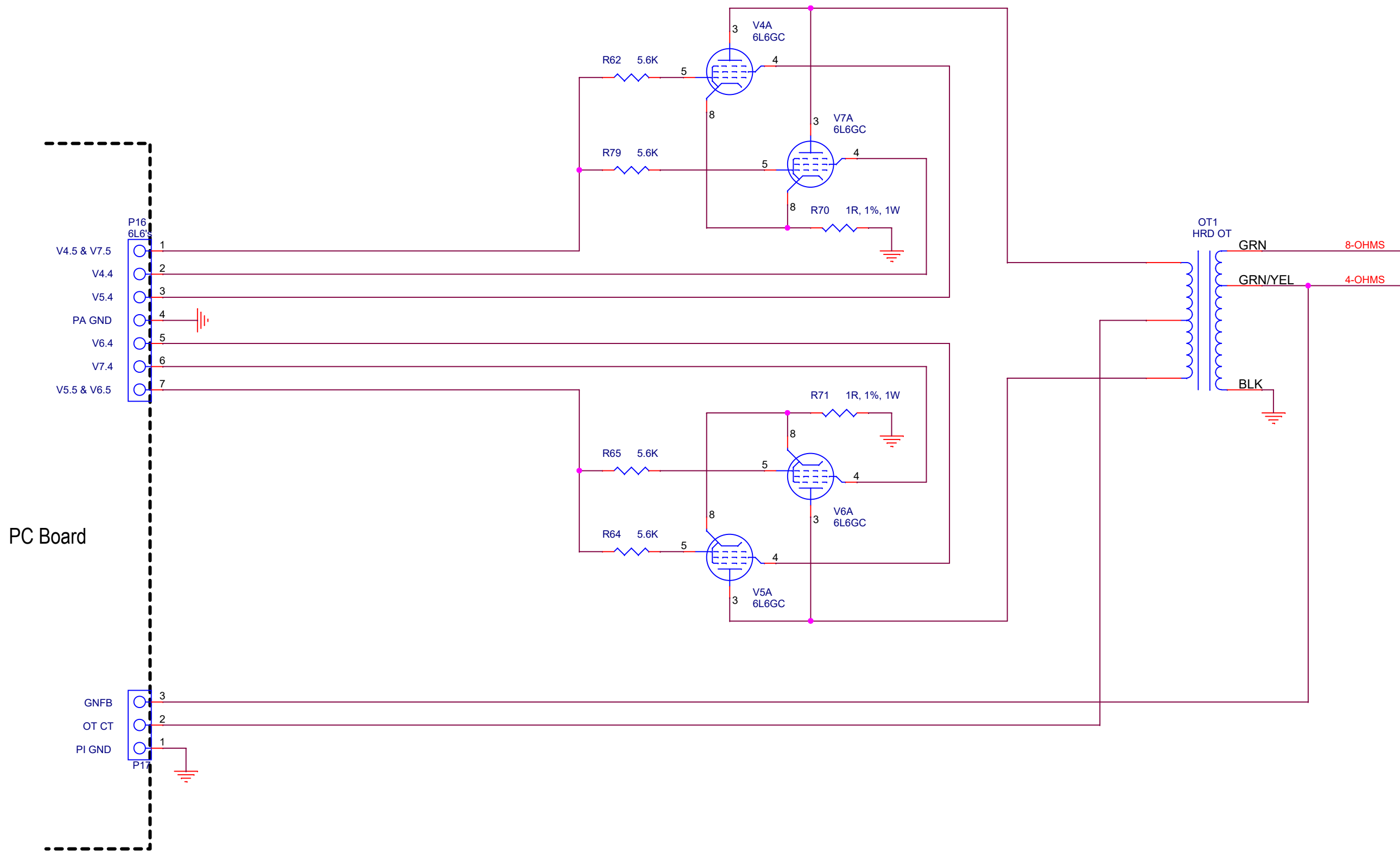

PC Board



Title		
SCHEMATIC, POWER AMP CHASSIS WIRING		
Size	Document Number	Rev
B	HRD to ODS	F2
Date:	Saturday, September 14, 2024	Sheet 2 of 3

PANASONIC DS2Y-2-DC12V
Pull-in V = 8.4V
Nom Coil DCR = 720R
MaxVin = 24V

LT1082 regulator in negative
to positive buck / boost mode.
Set for +15V output.

MOLEX CONNECTOR PART NUMBERS

	PCB HEADER	SCREW TERMINAL HOUSING
2POS	OQ0232500000G	TS02315A0000G
3POS	OQ0332500000G	TS03315A0000G
4POS	OQ0432500000G	TS04315A0000G
5POS	OQ0532500000G	TS05315A0000G
6POS	OQ0632500000G	TS06315A0000G
7POS	OQ0732500000G	TS07315A0000G

Title <Title>		
Size B	Document Number <Doc>	Rev F2
Date:	Saturday, September 14, 2024	Sheet 3 of 3