

5879 Pinout
Ground pins 2 & 6

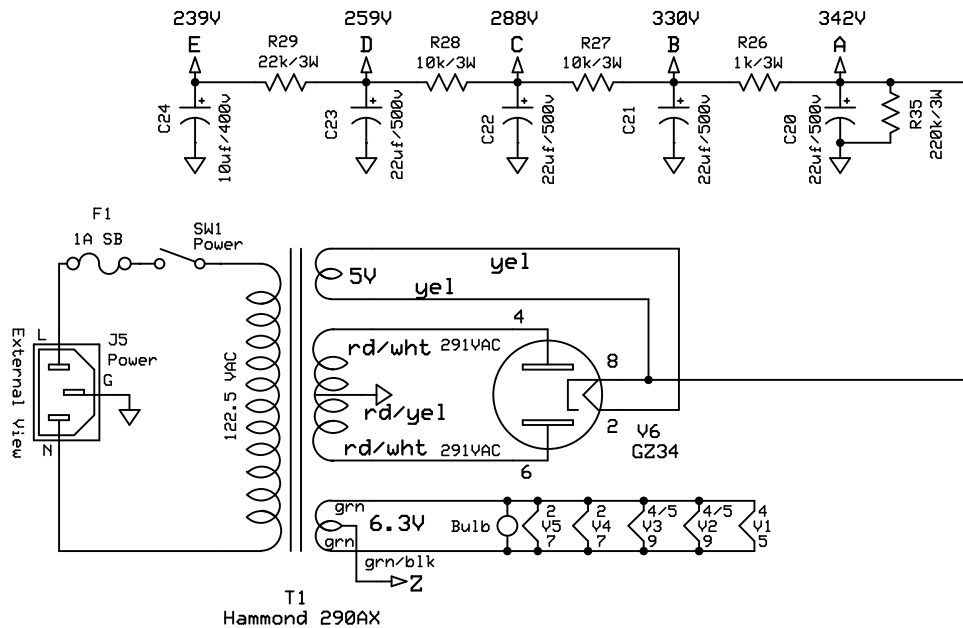

CHANGES FROM ORIGINAL:

- Input Stage
 - Remove C5 (150p) bypass cap on V1 plate
 - R7 (330k) to 1M, R6 (100k) to 220k
 - Connect C3 to cathode instead of ground
 - Change input grid resistor / remove feedback network on 5879
 - C2 to .01
- Plate bypass caps to B+ rather than ground, change values
- Remove original V2A gain stage, parallel with V2B.
- Split tone control into bass and treble 1M-A pots, add R32 120k mid resistor
- Added master volume and .02 cap before P1
- Add FX loop
- 6V6 Rk to 270ohm, bypass cap to 100uF, add 1.5k grid & 470R screen resistors
- Removed NFB
- Removed R25 in power supply
- C20 to 22uF to save rectifier
- Add R35 (PS Cap Bleed Resistor)

Filmosound 385		
Modified From Original		
BY: ADRIEN	Rev 4.1	Page 1 of 1
	26/03/2025	