

# SVT (REV A)

# Ampeg

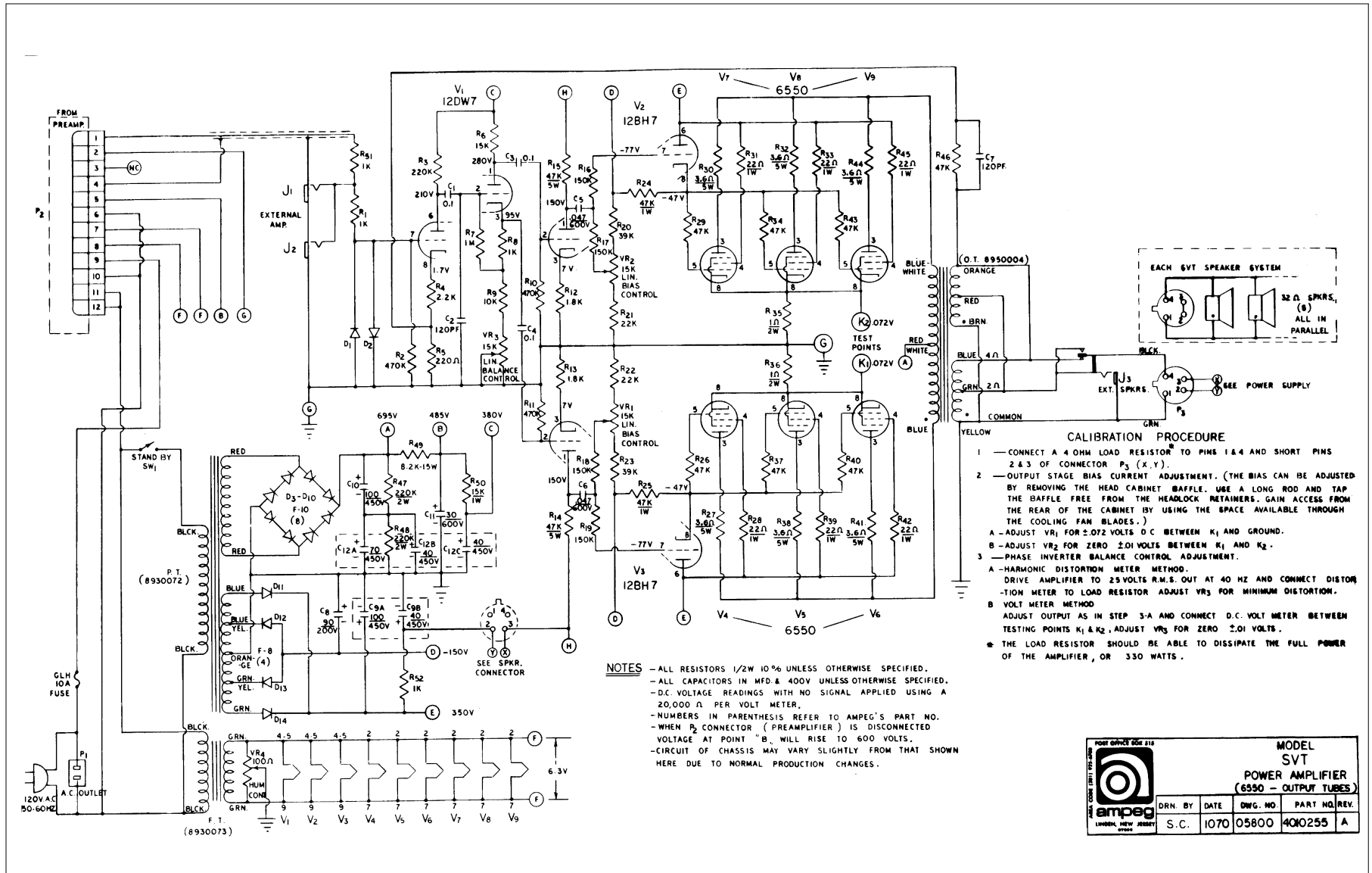

	MODEL SVT			
	POWER AMPLIFIER (6550 - OUTPUT TUBES)			
DRN. BY	DATE	DWG. NO.	PART NO.	REV.
S.C.	1070	05800	40K0255	A