

WARBLER DRILL GUIDE

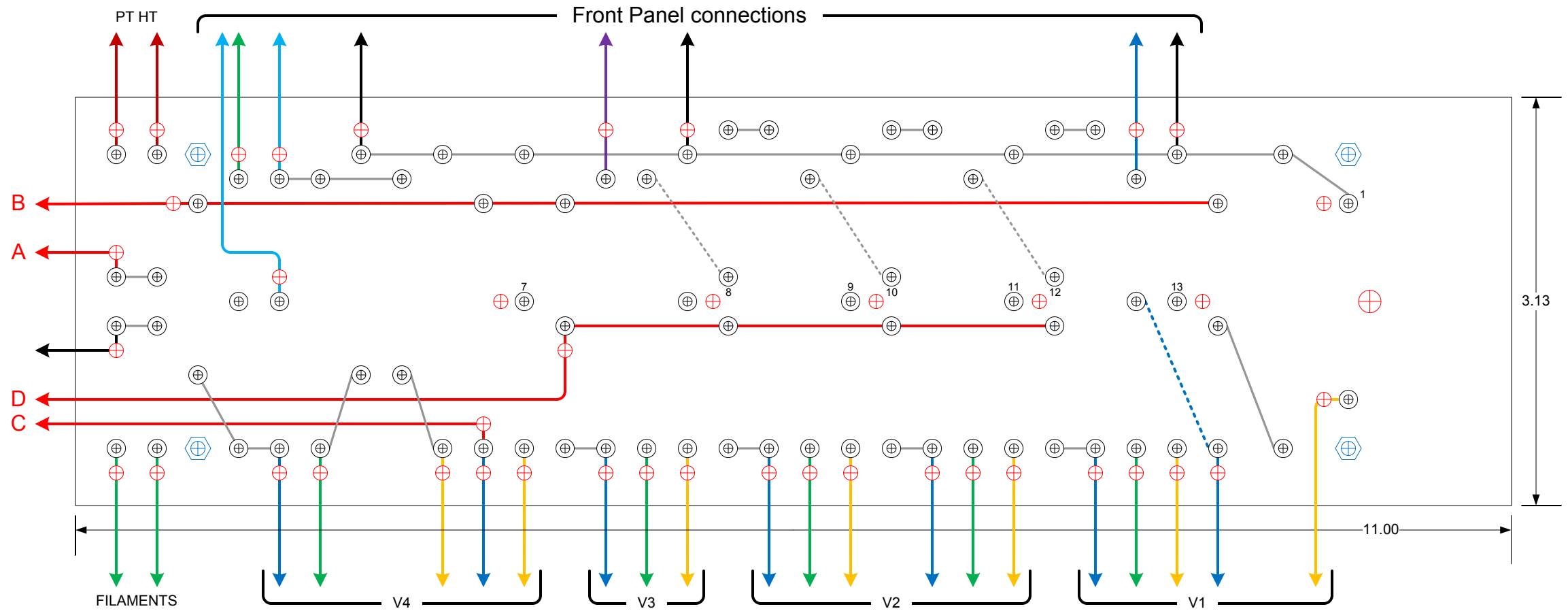

- ⊕ Turret --- drill size is 3/32"
- ⊕ Standoff – drill size to fit
- ⊕ Hole for wire pass thru – drill size to fit
- Dashed lines are underboard jumpers

INSTRUCTIONS

Board size is 3 1/8" X 11". Print this drill guide FULL SIZE on legal sized paper. Measure the board length of the printout to verify it is 11". Attach to blank board using double sided carpet tape. Use a center punch to put a mark at the cross hairs of each turret, standoff, and hole. Use a 3/32" drill bit to drill all holes. Then enlarge holes for standoffs and wire pass thru. The pass thru hole on the right end of the board will have 8 wires in it. I used # 24 wire and a #1 drill bit.