

VOX

NO. V-1-5

VOX AC-15 AMPLIFIER

AMERICAN TUBE NUMBER IN PARENTHESIS

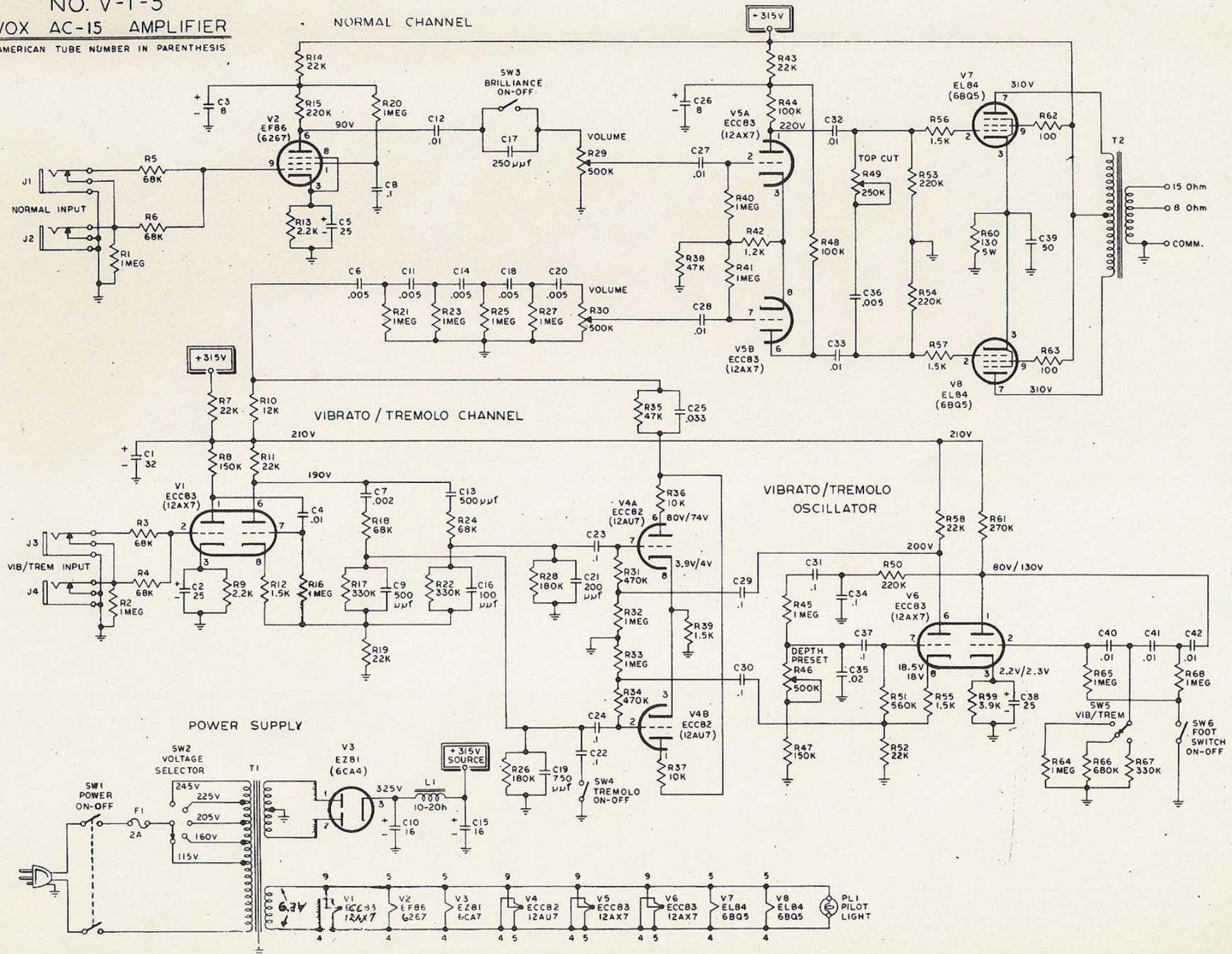

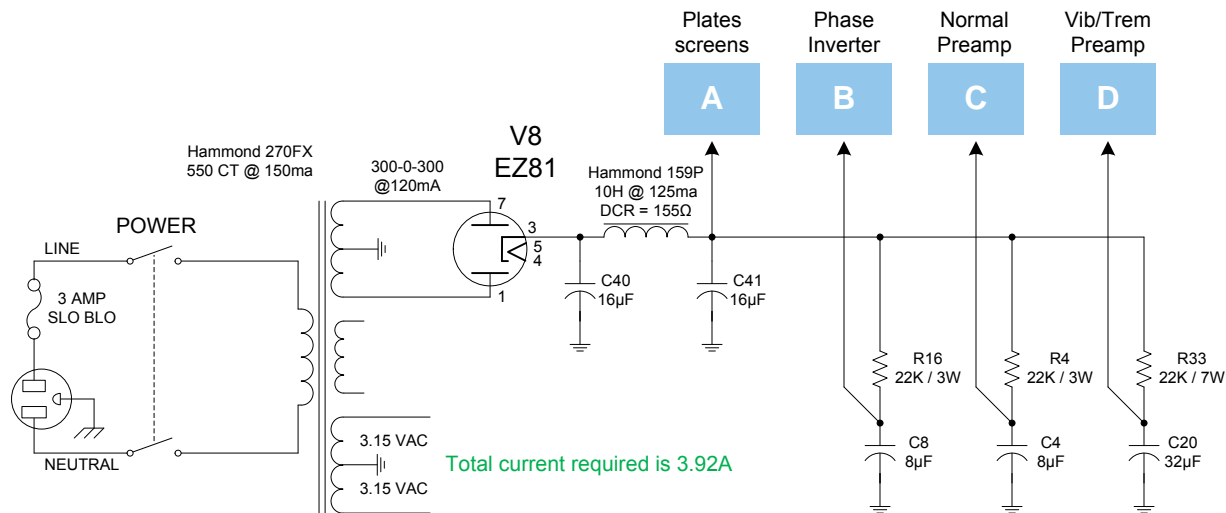
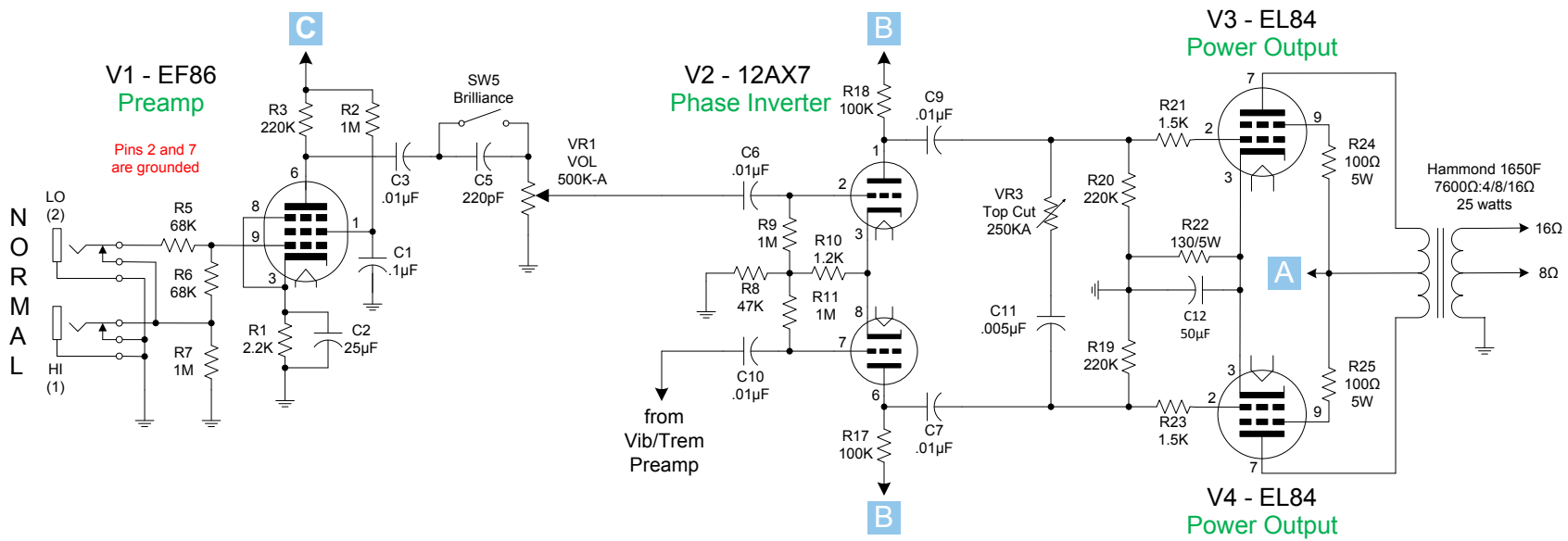

Fender style cap can/board

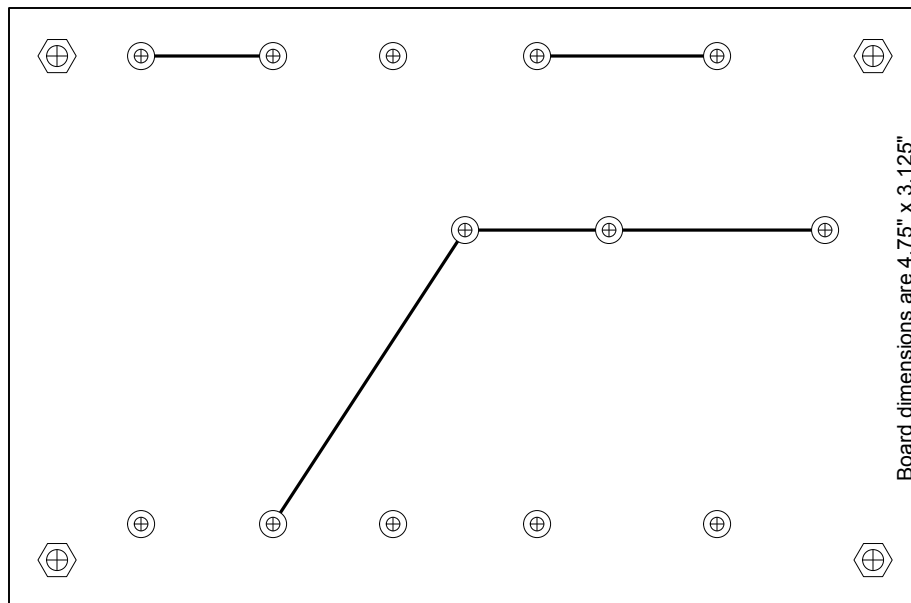
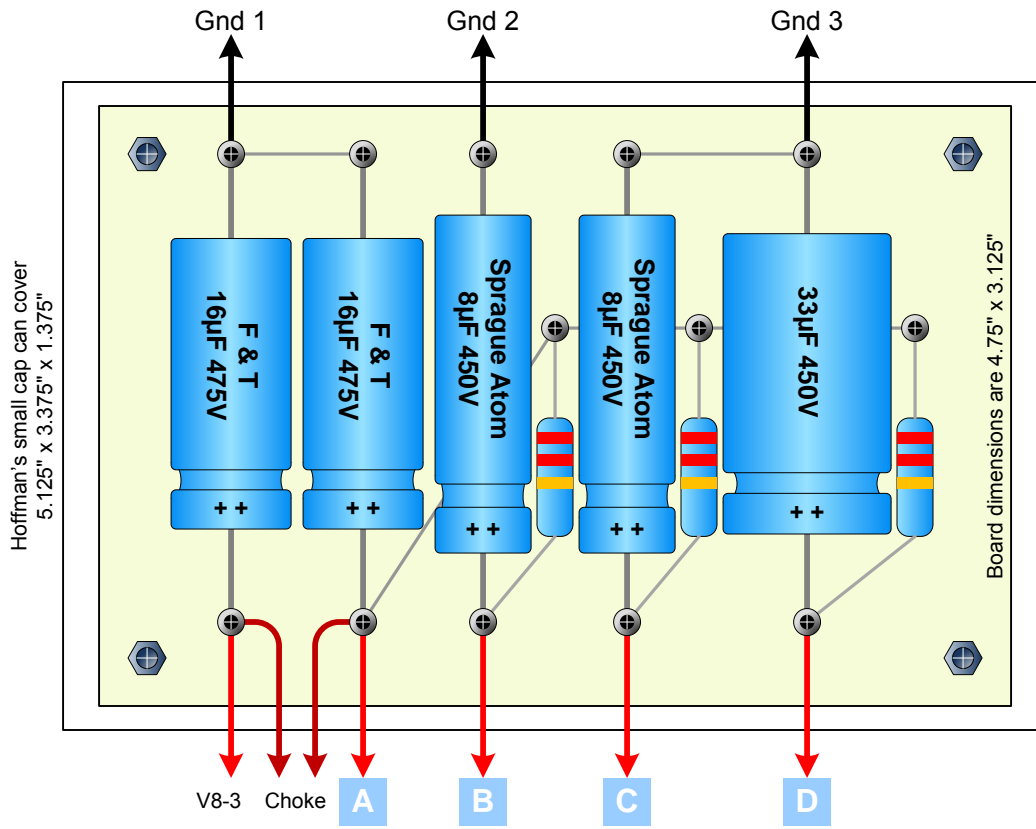

⊕ Turret --- drill size is 3/32"

⊕ Standoff – drill size to fit

⊕ Hole for wire pass thru – drill size to fit

----- Dashed lines are underboard jumpers

INSTRUCTIONS

Board size is 3 1/8" X 11 3/4". Print this drill guide FULL SIZE on 11" X 14" paper. Measure the board length of the printout to verify it is 11 3/4". Attach to blank board using double sided carpet tape. Use a center punch to put a mark at the cross hairs of each turret, standoff, and hole. Use a 3/32" drill bit to drill all holes. Then enlarge holes as needed for standoffs and wire pass thru.

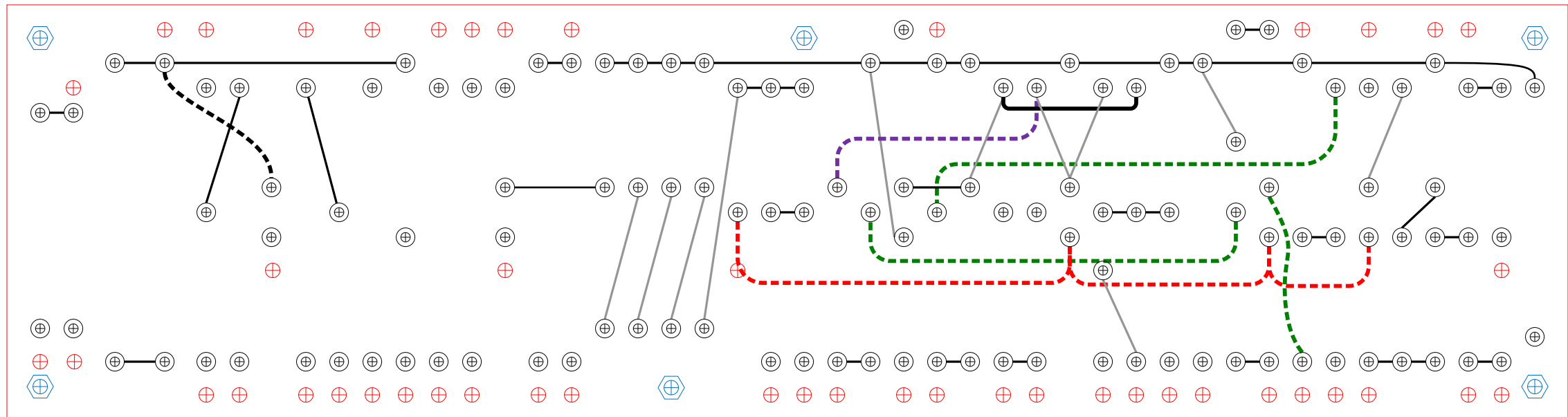
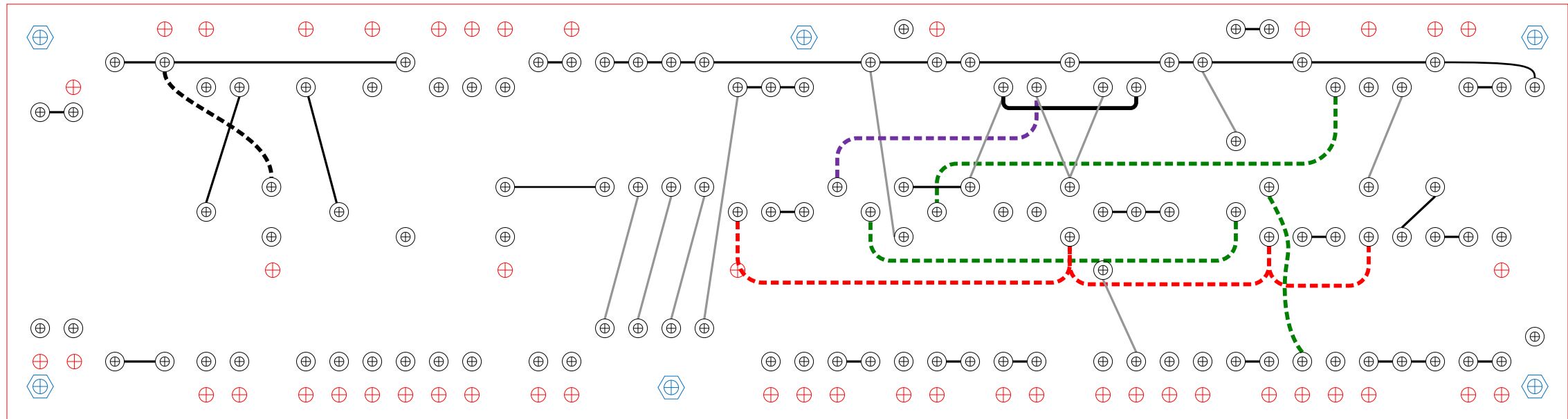



Chassis 17" X 6½" X 2½"
for planning purposes

Chassis available from
<http://www.turretboards.com>

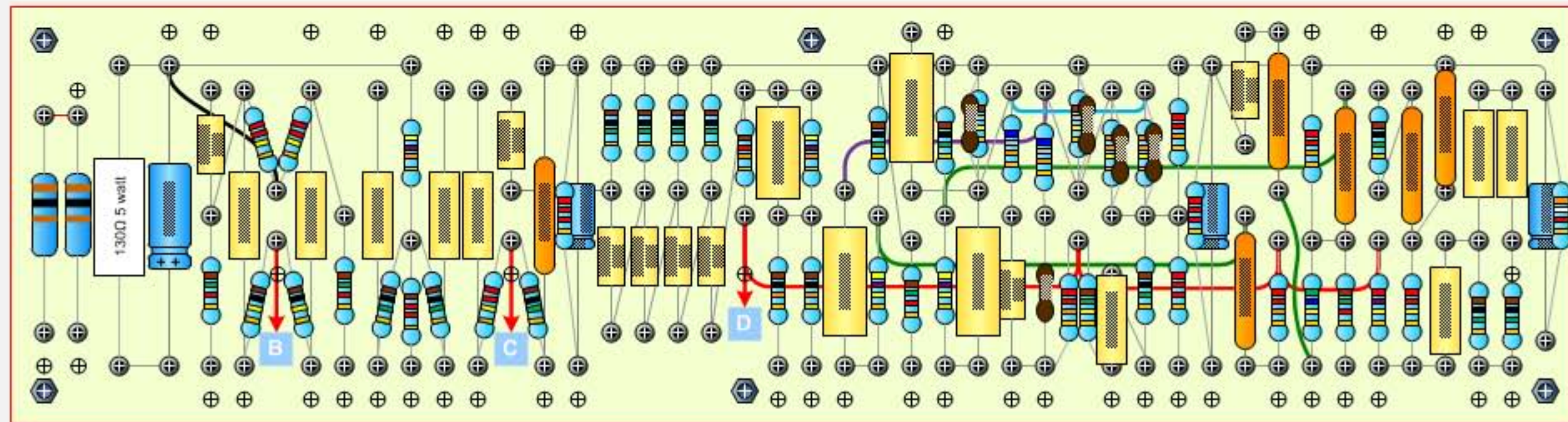

V8 - EZ81
Rectifier



V4 - EL84
Power



V3 - EL84
Power



V2 - 12AX7
Phase Inverter

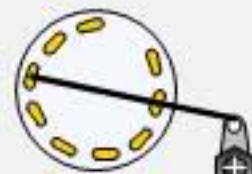

V1 - EF86
NOR Preamp



V6 - 12AU7
Modulator



V5 - 12AX7
Vib Preamp



V7 - 12AX7
Trem/Vib

Vox AC-15 Parts List

63 RESISTORS			43 CAPACITORS			POTS		
Quantity	Value	Power	Quantity	Value	Voltage	Quantity	Value	Comment
2	100	5	3	25	25	2	500K-A	Volume
1	130	5	9	0.1		1	250K-A	Top Cut
1	1200		9	0.01		1	1M-A	Depth
4	1500		1	220p				
3	2200		7	0.005				
1	3900		1	50	25			
2	10000		2	16	450			
1	12000		2	8	450			
2	22000	3	1	32	450			
1	22000	7	1	0.0022				
4	22000		2	500p				
1	47000		1	750p				
1	47000		1	100p				
6	68000		1	200p				
2	100000		1	0.022				
1	150000		1	0.033	(maybe 0.047)			
2	180000							
4	220000							
1	270000							
3	330000							
2	470000							
2	560000							
16	1000000							