

Build Your Own *Vibrato*



IF YOU OWN an electronic musical instrument or a conventional instrument equipped with a pickup, chances are that the vibrato described in this article is just what you've always wanted.

A vibrato is a device which continuously and automatically varies the amplitude of the music at a low rate of speed, usually somewhere in the range of 6 to 15 times per second. For instance, it is a vibrato which produces the soul-stirring throbbing, especially in the bass notes, of a pipe organ.

Construction. Layout and wiring are not especially critical. For convenience a turret socket was used to mount the oscillator tube, *V1*, and its components, but a standard socket and tie points will do as well.

Miniature coaxial jacks, of the type found on most hi-fi amplifiers, were used at *J1* and *J2* for the output and input con-

*Make like Elvis
with an "electronic"
throbbing guitar*

By FRANK H. TOOKER

nections, respectively. If your setup requires something different, any conventional type of jack may be employed.

Keep the power supply components well separated from the oscillator and modulator components, to prevent hum pickup—and orient the tube sockets for reasonably short lead connections. Make sure that the 6.3-volt heater leads are dressed snugly against the chassis and that they are well separated from grid terminals and leads.

A miniature amplifier foundation (Bud No. CA-1754) was used for a chassis (any other setup of suitable size can be substi-

tuted). The Bud chassis measures 5" x 7" x 2", and its over-all height with the grille cover in place is 6". The finish is black crackle—but if some other color appeals to you, it's a simple matter to go over the chassis with a couple of coats of plastic spray.

In some instances, it may be possible to mount the vibrato circuit proper on the same chassis with the musical instrument amplifier. This can be done provided that there is room, and that the power transformer in the amplifier can supply the 0.6-ampere additional filament current de-

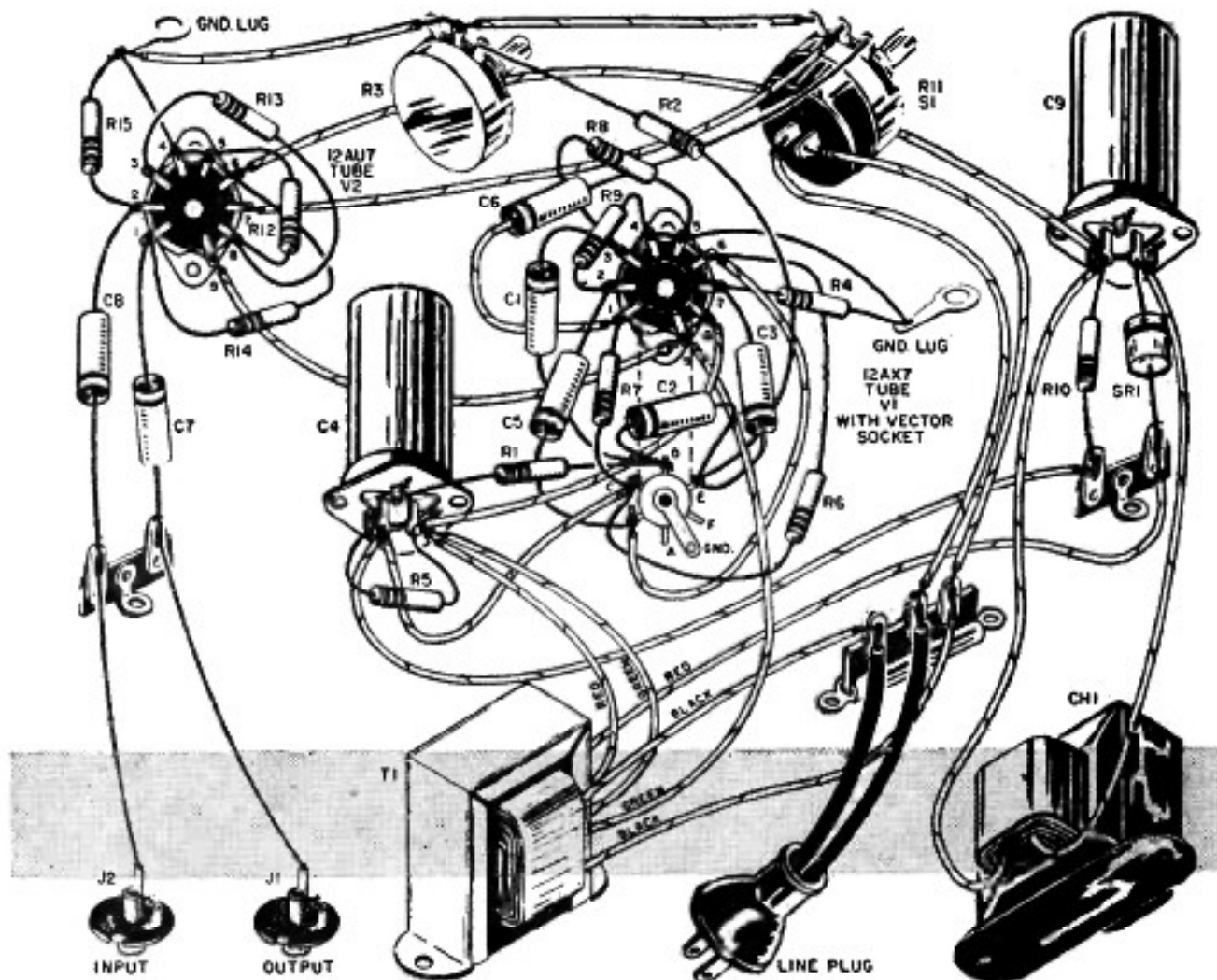

PARTS LIST

C1, C2, C3, C5—0.05- μ fd., 200-volt, metalized paper capacitor
 C4a/C4b—20/20- μ fd., 150-volt, dual electrolytic capacitor
 C6, C7, C8—0.02- μ fd., 200-volt, paper capacitor
 C9a/C9b—40/40- μ fd., 250-volt, dual electrolytic capacitor
 CH1—3.5-henry, 50-ma. filter choke
 J1, J2—Miniature phono jack
 R1, R4, R7, R8, R10—220,000-ohm, $\frac{1}{2}$ -watt resistor
 R2, R5—100,000-ohm, $\frac{1}{2}$ -watt resistor
 R3—500,000-ohm potentiometer (Rate control)
 R5—10,000-ohm, $\frac{1}{2}$ -watt resistor
 R9—3.9-megohm, $\frac{1}{2}$ -watt resistor

R11—500,000-ohm potentiometer (Depth control)
 R12—27,000-ohm, $\frac{1}{2}$ -watt resistor
 R13—560-ohm, $\frac{1}{2}$ -watt resistor
 R14—47,000-ohm, $\frac{1}{2}$ -watt resistor
 R15—470,000-ohm, $\frac{1}{2}$ -watt resistor
 S1—S.p.s.t. switch (on Depth control)
 SR1—20-ma., 130-volt selenium rectifier
 T1—Miniature power transformer, 125 volts at 15 ma., 6.3 volts at 0.5 amp. (Stancor PS-8415)
 V1—Type 12AX7 tube
 V2—Type 12AU7A tube
 I—Miniature amplifier foundation chassis or equivalent (see text)
 I—Turret-type miniature 9-pin tube socket
 I—Miniature 9-pin tube socket
 Misc. hardware, grommets, tie points, etc.

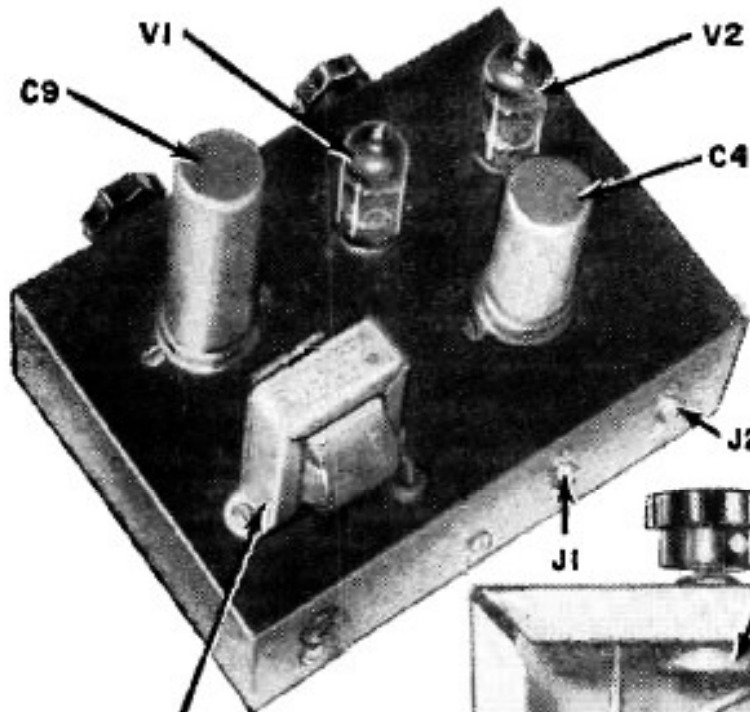

Top and bottom views of the vibrato chassis are seen at left and below. Twist the lugs of the can-type filter capacitors so that the filters are tight to their metal mounting plates.

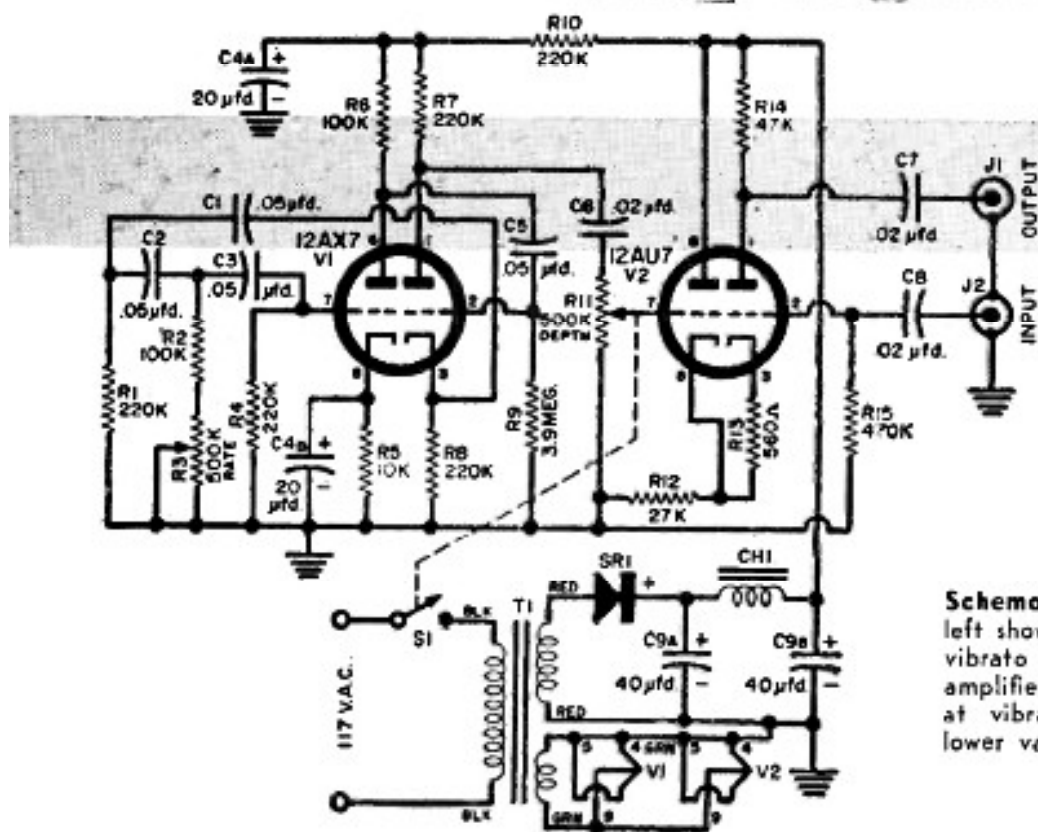
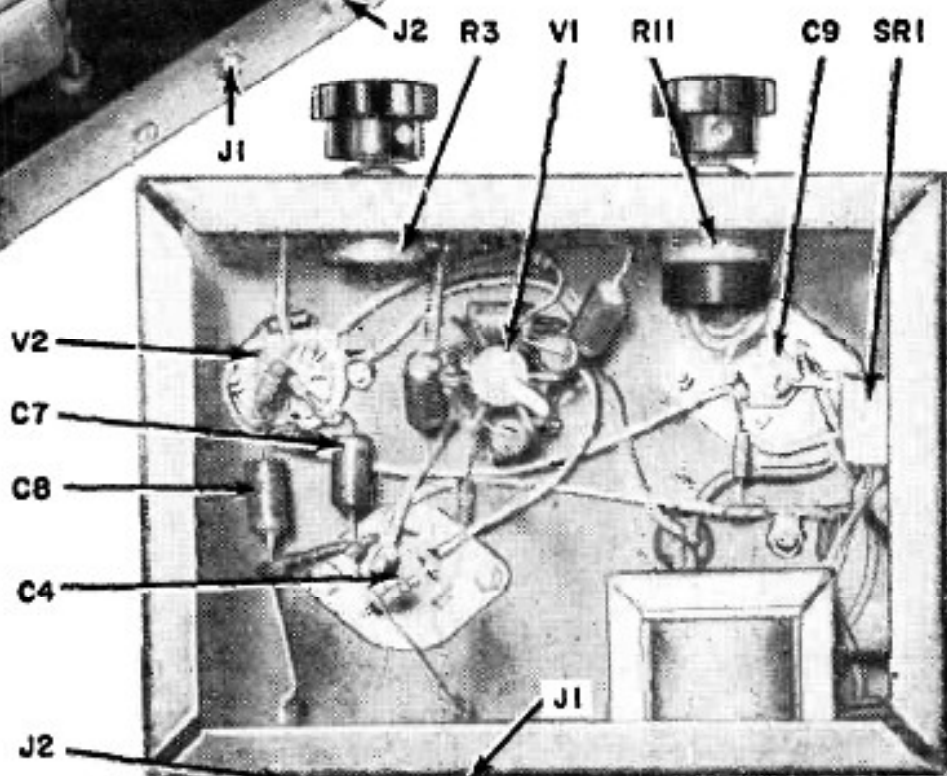

Schematic and pictorial at left show the simplicity of the vibrato construction. If your amplifier tends to "thump" at vibrato frequency, try a lower value capacitor for C7.

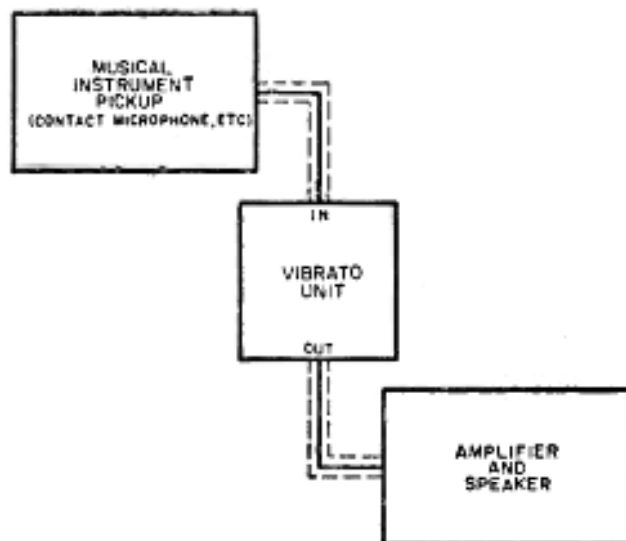

Block diagram shows correct interconnection of the three basic components of the revised setup. Use shielded microphone cable between units to prevent electrostatic hum pickup. If there seems to be excessive 60-cycle hum present, try reversing line plug of either amplifier or vibrato unit.

manded by the two vibrato circuit tubes. The plate voltage requirement is approximately 175 volts.

Hooking It Up. The vibrato is intended to be inserted or connected between the musical instrument and its amplifier. All you have to do to use it is unplug your musical instrument from its amplifier and plug it into the *input* jack of the vibrato. Then connect a jumper cable of convenient length between the *output* jack of the vibrato and the *input* jack of the amplifier.

The *Rate* control determines the rate or frequency of the vibrato effect, i.e., the

HOW IT WORKS

The schematic shows that the vibrato consists of two parts: (1) a very low frequency audio oscillator, and (2) a modulator. The low-frequency oscillator is of the phase-shift type which uses resistors and capacitors $C1$, $C2$, $C3$, $R1$, $R2$ plus $R3$, and $R4$ in three RC sections to obtain feedback in the proper phase to produce oscillations. The rate or speed of the vibrato, i.e., the frequency of the oscillator, is determined by the resistance and the capacitance used in the RC sections. Thus, $R3$ is the *Rate* or speed control of the vibrato.

$V1$'s second triode section serves a dual purpose: (1) it provides a low source impedance for the RC feedback loop (taken from the cathode), and (2) it acts as a buffer to isolate the oscillator from the connection to the modulator (taken from the plate).

The low-frequency oscillator signal is fed through the gain or *Depth* control, $R11$, to the control grid of one section of the twin-triode modulator, $V2$. At the same time, the output signal from the musical instrument is fed through to the control grid of the second section. The two signals mix in $V2$, with the result that the gain or amplification of the musical signal is made to increase and decrease, smoothly and periodically, at the rate of the low-frequency oscillations. Output from the modulator is taken through $C7$ and coupled to the input of the musical instrument's conventional amplifier.

Plate current demand is very small, so a miniature power transformer, $T1$, and a miniature selenium rectifier, $SR1$, more than meet the requirement.

speed at which the rise and fall in amplitude occurs. Proper setting of this control depends upon the type of instrument with which the vibrato is used and the type of music being played. Component values given in the parts list permit the unit to be adjusted over the most useful range of speeds.

The *Depth* or vibrato-frequency gain control determines the amplitude of the

POSSIBLE TROUBLES AND CURES

No Vibrato Effect: Check all wiring for errors. Make sure input and output plugs are making good contact in the jacks. Look for faulty components. Check the tubes. Make sure the 12AX7 tube is in the oscillator socket, the 12AU7 in the modulator socket, and not vice-versa. Check interconnecting cables for a poor solder joint or broken wire.

Distortion: Most, if not all, vibratos cause a certain amount of distortion. However, the effect should not be objectionable. Reduce the setting of the *Depth* control slightly to see if it improves the condition. If so, check the musical signal voltage at the input to the modulator. An input greater than 0.7 volt r.m.s. may cause distortion. Check the value of components around the modulator. Look for a possible defective component. And check the modulator tube.

Thumping in Speaker: A thumping noise at the vibrato rate may be due to low frequencies pulling the voice coil or cone out of linearity. This isn't likely to happen unless you have an amplifier with exceptionally heavy bass response. A high-pass filter cutting off at about 100 cycles inserted between the vibrato and the amplifier may be necessary in such cases if all else fails.

Hum: Hum can come from a variety of sources such as a poor layout of components, excessively long leads or poor lead dress, a defective modulator tube, faulty filter choke or capacitors, unshielded interconnecting cables or cables with the shield ungrounded to chassis, using the unit close to power wiring carrying heavy a.c. currents, etc. All of these possible troubles can be easily corrected.

vibrato effect. The more this control is advanced, the more pronounced the vibrato effect becomes. Proper setting depends upon the strength of the musical signal fed to the modulator as well as on the type of instrument and the selection being played.*

Probably the best method is to adjust the *Rate* and *Depth* controls for the most pleasing effect. You can get some idea as to proper settings by listening to recordings in which a vibrato is used. Many beginners tend to use too much vibrato, or to use it too frequently. Much can be learned by listening to professionals. —30—

* Maximum musical signal voltage should not be greater than approximately 0.7 volt, to prevent overloading the unit. Optimum operation occurs with a musical signal input from the contact microphone between 0.5 and 0.7 volt.

Electronic Echo Chambers

■ I have recently built an amplifier for use with a guitar and have used the vibrato circuit in your December 1957 issue. However, the person for whom the amplifier was built would like to have an echo chamber added, if possible. Have you ever published such a circuit?

EDWARD JENSEN
Stamford, Conn.

■ I play in a small band and would like to install an "echo" effect in our p.a. system, i.e., one which electronically repeats the attack on the notes. I would like to build this myself.

STEPHEN M. EHMELA
Chicago 51, Ill.

An electronic echo chamber is difficult to design. The effect can be achieved acoustically, however, with a long hollow pipe or other mechanical delay device.

Vibrato or Tremolo?

■ I would like to take exception to the article entitled "Build Your own Vibrato," December 1957. My contention is that the circuit described does not add "vibrato" but "tremolo" to the input signal.

To the prospective builder I would point out that there is a world of difference between the two effects. The article states that it is "the vibrato which produces the soul-stirring throbbing, especially in the bass notes, of a pipe organ." If we consult Webster, he states correctly that vibrato is a "slightly tremulous or pulsating effect (but no tremolo) for adding warmth and beauty . . . it consists of slight and rapid variations in the pitch of the tone being produced." Note that the effect is that of a pitch (frequency) change, not amplitude.

Let us examine the circuit described. The author states that there are three important functions; a phase shift oscillator, an amplifier-modulator, and a mixer. Actually, the net result is a stage

of signal amplification where the gain of the amplifier is varied at a preset rate and in a preset amount to produce tremolo, a change in volume level.

As for examples of vibrato, the electronic organ generally uses a low-frequency oscillator (6-8 cps) to modulate the supply voltage for the various tone oscillators. This causes the pitch (frequency) to vary at the same rate and in excursion (FM, if you will) by the depth of modulation.

The Hammond organ, with a mechanical tone generator, uses a complicated mechanical phase delay line which essentially splits the signal tone into two paths, straight through and delayed, and recombines the signals with a random phase delay. In stringed instruments it is produced by a rapid rocking of the player's finger on the string.

As for the soul-stirring pipe organ, this total effect is due to reverberation, phase cancellation of some frequencies, and downright poor acoustics. It is pretty difficult to alter the length of a pipe (pitch change) at a 7-cps rate; in fact, it just isn't done . . . !

This is not to deny the existence of electronic vibrato circuits—the Wurlitzer organ uses one—but a circuit which will affect the pitch of a tone after it is generated unfortunately just doesn't turn out to be a simple two-tube device.

JOSEPH F. CURRAN
Neptune, N. J.

Not being music connoisseurs, we sought advice from two experts (?) in the field when we edited the article. We must have been misled.

■ I was fortunate to acquire the December 1957 issue of P.E. and built the "Throbbing" Vibrato. I am very pleased with the results. It is wonderful.

ARNOLDO VARELA
Chitre, Prov. Herrera
Republic of Panama