

Rock-Ola Model 1442 Jukebox Amplifier Conversion

Conversion by Steve Luckey, 08/20/09

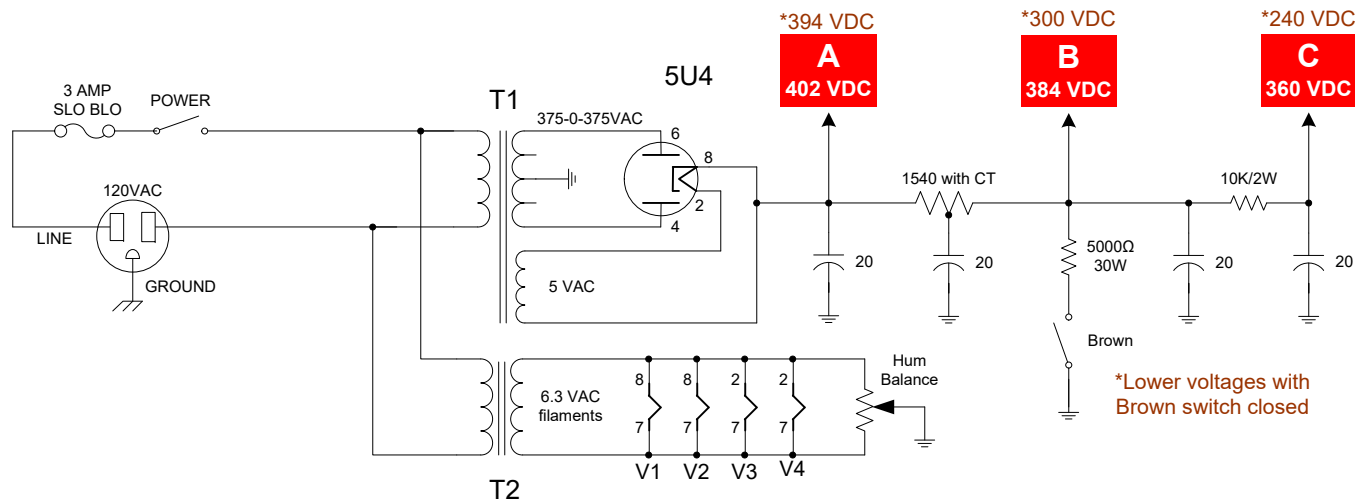
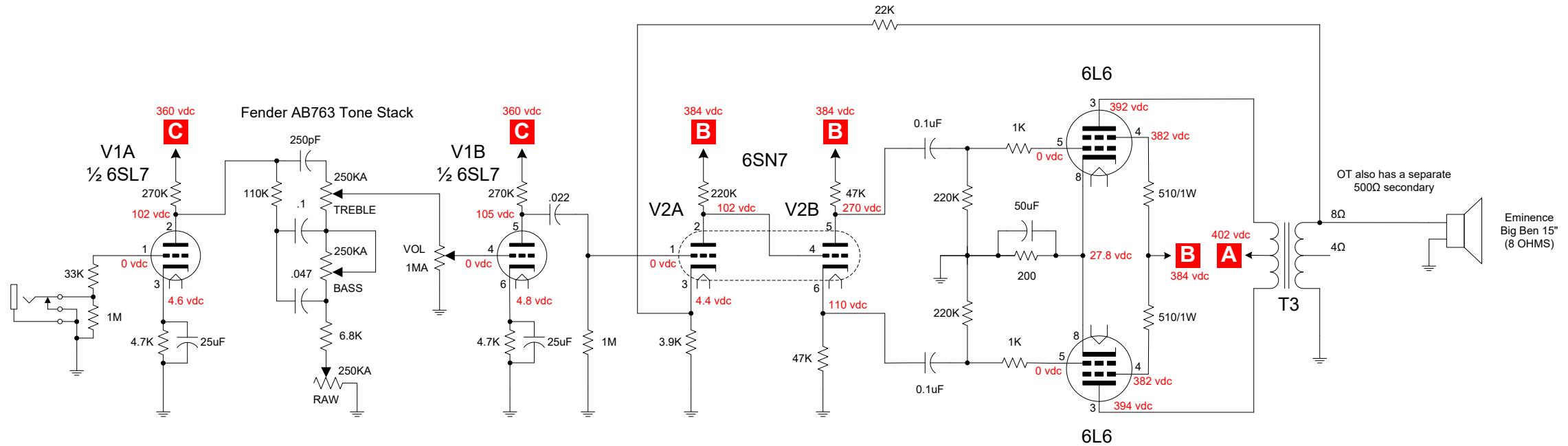

- ### Conversion notes
- Converted V1B cathode follower to a gain stage identical to V1A.
 - Replaced James tonestack with Fender AB763 tonestack plus Raw control.
 - Removed Hi cut filter at input to split phase inverter/driver.
 - Removed 75pF cap in NFB loop.
 - Replaced 100KΩ grid resistors for 6L6s with 220KΩ.
 - Installed 510Ω screen grid resistors.
 - Replaced field coil with 5KΩ 30W resistor and added Brown switch.
 - Replaced 6.8KΩ dropping resistor for Node C with 10KΩ 2W resistor.
 - Added onboard filament transformer T2.