

Bias circuit and full wave bridge

(from Marshall JCM900 and some old Ampegs)

How does it work?

The test bias circuit inside the blue circle was just breadboarded and connected via clip leads to the power supply of my Revibe. The AC at the bridge is a pulsing positive DC waveform. C1/R1 couple this waveform to the input of the diode and also shift the baseline such that the waveform now has a positive as well as negative half cycle.

Shifting the baseline in this manner is the key to the operation of this bias circuit.

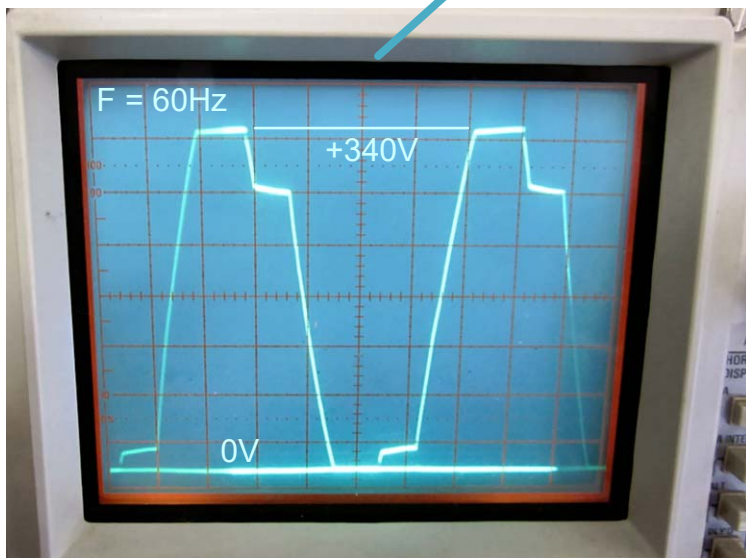
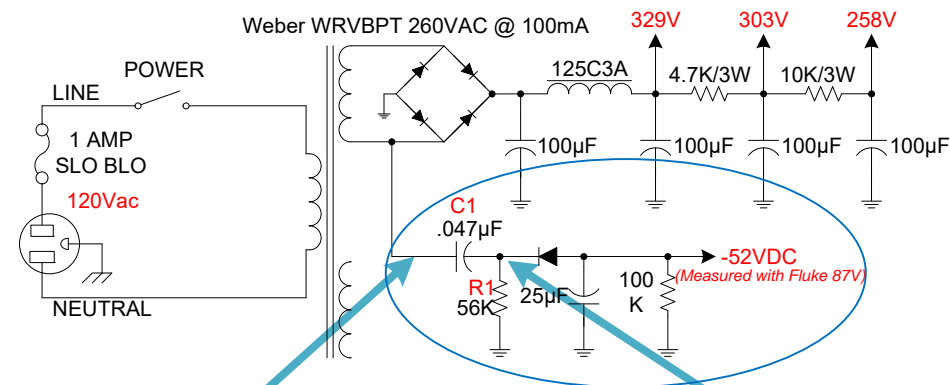

340VAC_{pp} with 0V baseline

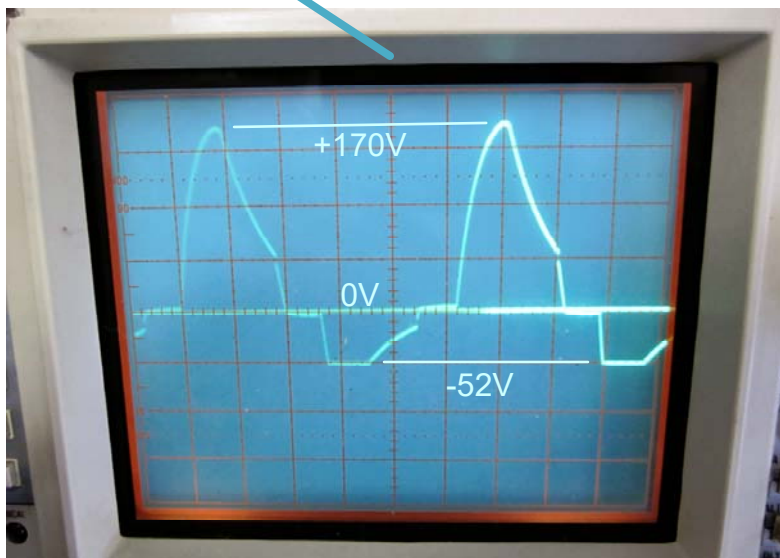

222VAC_{pp} (170V positive, 52V negative)

Notice that this waveform never goes negative with respect to ground. If you were to apply this signal directly to the cathode of this simple half wave rectifier, the diode would block the entire waveform and the resulting DC output would be zero volts.

Well, C1 and R1 have certainly affected the shape and amplitude of the input AC waveform. But more important, the baseline has shifted and now a portion of the signal goes below zero volts. The diode blocks the positive portion and passes the negative portion. The resulting unloaded DC output is now -52VDC.