

TUBE VOLTAGE CHART

	1	2	3	4	5	6	7	8	9
V1	206	0	1.5	htr	htr	203	0	1.5	htr
V2	424	0	7.5	htr	htr	424	0	7.5	htr
V3	206	0	1.8	htr	htr	209	0	1.8	htr
V4	196	* -1.5	77.5	htr	htr	194	* -1.5	77.5	htr
V5	nu	htr	423	425	-36	nu	htr	24mv	x
V6	nu	htr	423	425	-36	nu	htr	24mv	x
V7	nu	htr	nu	330vac	nu	330vac	nu	htr	x

Measured with Fluke 87 III DMM. All controls max CCW. Amp warmed up for 30 minutes.

* V4 grid (2,7) voltages measured in respect to cathodes (3,8).

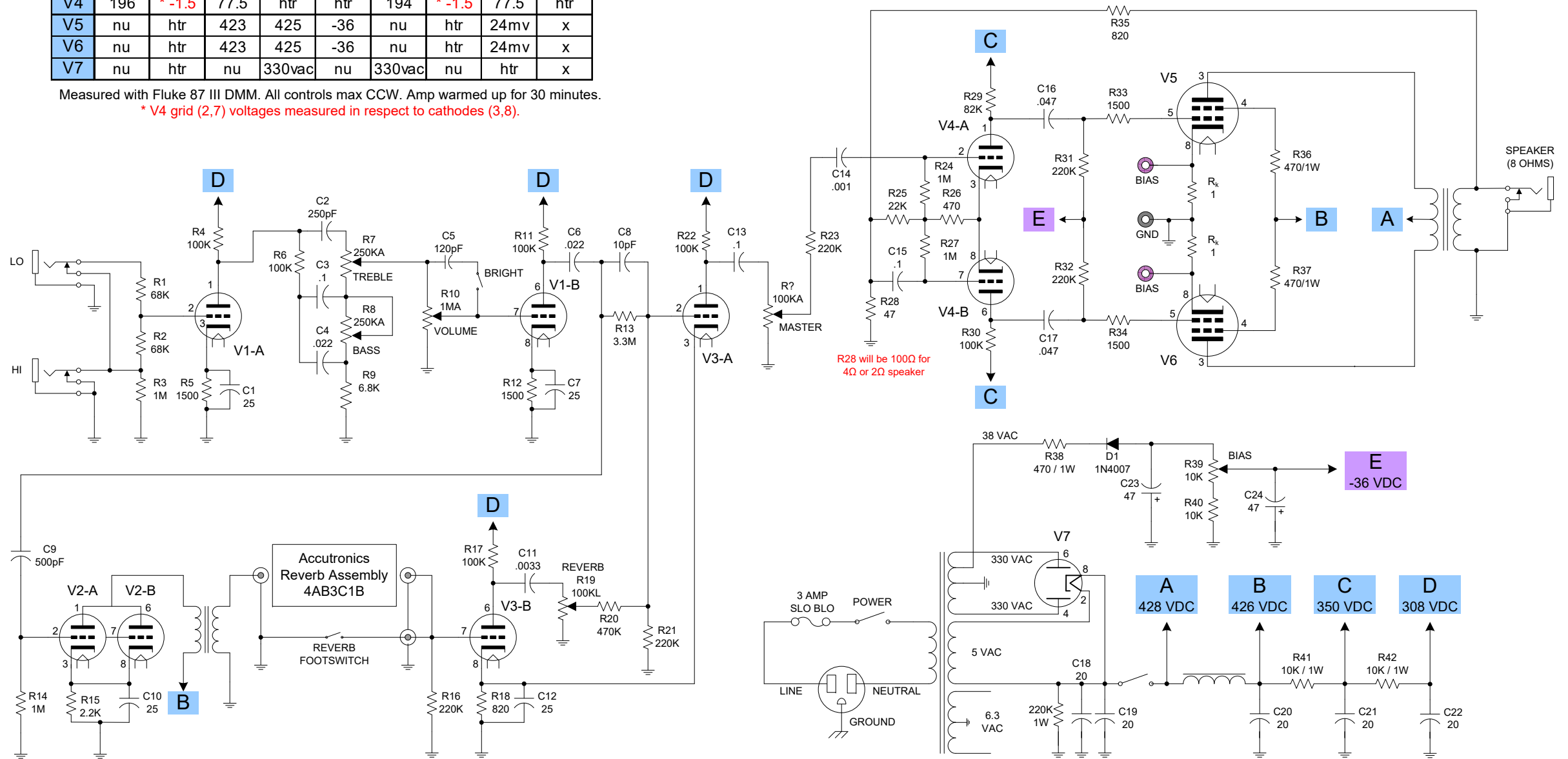

TWEED DELUXE REVERB designed by Steve Luckey. (2006)

Schematic is based on Fender Deluxe Reverb AB763 circuit.

R28 will be 100Ω for 4Ω or 2Ω speaker

