

COMPACT HI-FI POWER AMPLIFIER

By MELVIN LEIBOWITZ / Delaware Electronics Supply Co.

Constructing a 6-watt amplifier in which the output tubes serve as their own phase inverter.

***note to self: Self Split output stage info here

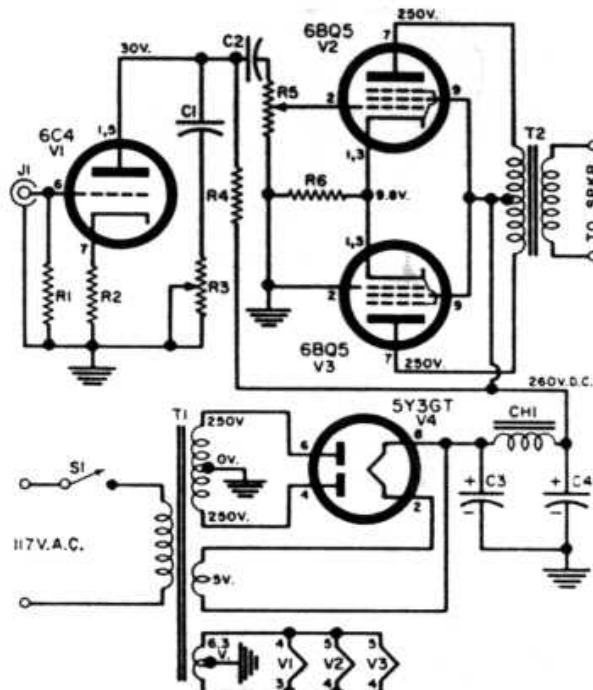

R_1 —470,000 ohm, $\frac{1}{2}$ w. res.

R_2 —4700 ohm, 1 w. res.

R_3 —100,000 ohm pot

R_4 —560,000 ohm, $\frac{1}{2}$ w. res.

R_5 —500,000 ohm audio-taper pot

R_6 —130 ohm, 2 w. res. $\pm 5\%$

C_1 —.02 μ f., 600 v. capacitor

C_2 —.1 μ f., 600 v. capacitor

C_3, C_4 —20/20 μ f., 450 v. elec. capacitor

J_1 —Phono jack

CH_1 —5-15 hy., 75 ma. filter choke

S_1 —S.p.s.t. switch

T_1 —Power trans. 250-0-250 v. @ 75 ma.; 5 v. @ 2 amp; 6.3 v. @ 2.5 amp. c.t.

T_2 —Output trans. 8000 ohms c.t., 15 watts, to 3-4 ohm sec. (Triad S-21-A, see text)

V_1 —6C4 tube

V_2, V_3 —EL84/6BQ5 tube V_4 —5Y3GT tube

Circuit diagram of the amplifier. The signal for output tube V_3 is the voltage developed across unbypassed resistor R_6 .

MODERN tubes and components have done much to destroy the old-fashioned idea that high-fidelity amplifiers must be cumbersome and expensive. The unit to be described is a case in point. Excellent performance is obtained although a mere handful of lightweight, inexpensive components are required in the construction. The very simplicity of this circuit is partly responsible for its performance as there is so little to go wrong with it.

The design of this amplifier, as is the case with any amplifier, centers around the output stage. EL84/6BQ5 tubes were selected for the output stage for several reasons.

They will produce adequate power at low distortion with only 250 volts on the plates and screens. Plate current requirements are modest.

The most important consideration in the use of 6BQ5's was their low drive requirements.

Only 22.5 volts grid-to-grid are required to drive the tubes to full output.

Compared with the better known 6V6, the 6BQ5 will produce more output with lower distortion, less plate-current consumption, at about one-third less grid drive.

This means that if we use the 6BQ5, our power supply may be reduced in size and the voltage amplifier stages preceding the power amplifier stage may be simplified.

We have achieved a large part of our goal simply by choosing the correct output tubes.

A little unusual circuitry now comes into play to enable us to reach our goal of the "ultimate" in a simple, yet good, amplifier.

It will be noticed that there is no phase inverter in the amplifier and, at the same time, the hook-up of the output tubes is unconventional. The output tubes act as their own phase inverter. This type of circuit is not new and can be found in some of the audio hand books. The circuit is not used much despite its advantages of good inherent balance, simplicity, and low drive requirements. There are those words "low drive" again! Only one tube is driven in this circuit as opposed to two in the normal type of output stage. This means that the required driving voltage is halved which, in this case, now amounts to 11 volts. Almost any tube will supply the required 11 volts when driven from a ceramic phonograph cartridge, FM tuner, or tape deck so we eliminate the multi-tube input stages found in most amplifiers and end up with a single 6C4.

Inasmuch as we do not have a great deal of voltage amplification we do not need a lot of filtering in the power supply, hence almost any filter choke and capacitors will do the job. Since we are not striving for maximum gain in the input stage, the cathode resistor has not been bypassed, thus giving us desirable

inverse feedback and saving the cost of the bypass capacitor.
Some further information about the output stage is in order.
The plate current of V1 varies in accordance with the signal.
The voltage across the cathode resistor, R will also vary as a result.
Thus there is a component of signal voltage on the cathode of V.
Since the cathode of V: is in parallel with that of V.
it will also have signal impressed on it and since the grid of V.
is grounded the cathode will swing around the grid which is
equivalent to having the grid swing around the cathode as
we are accustomed to having it. The cathode resistor must
not be by-passed (by a capacitor). (←Maybe this is only for HiFi use???)
None of the parts in the amplifier are critical, however,
you should make every effort to get the output transformer
of the impedance and power specified in the parts list.
This amplifier has plenty of high frequency response so tone
controls have been kept to a minimum and only a simple treble
attenuator is employed. The output power is just over 6 watts
before the scope shows any noticeable distortion.

*My thoughts are to use this for a higher powered Firecracker-type amp w/ high
overdriving gain and Marshall/Soldano crunch!?!