

TUBE VOLTAGE CHART

	1	2	3	4	5	6	7	8	9
V1	206	0	1.5	htr	htr	203	0	1.5	htr
V2	424	0	7.5	htr	htr	424	0	7.5	htr
V3	206	0	1.8	htr	htr	209	0	1.8	htr
V4	196	* -1.5	77.5	htr	htr	194	* -1.5	77.5	htr
V5	nu	htr	423	425	-36	nu	htr	24mv	x
V6	nu	htr	423	425	-36	nu	htr	24mv	x
V7	nu	htr	nu	330vac	nu	330vac	nu	htr	x

Measured with Fluke 87 III DMM. All controls max CCW. Amp warmed up for 30 minutes.

* V4 grid (2,7) voltages measured in respect to cathodes (3,8).

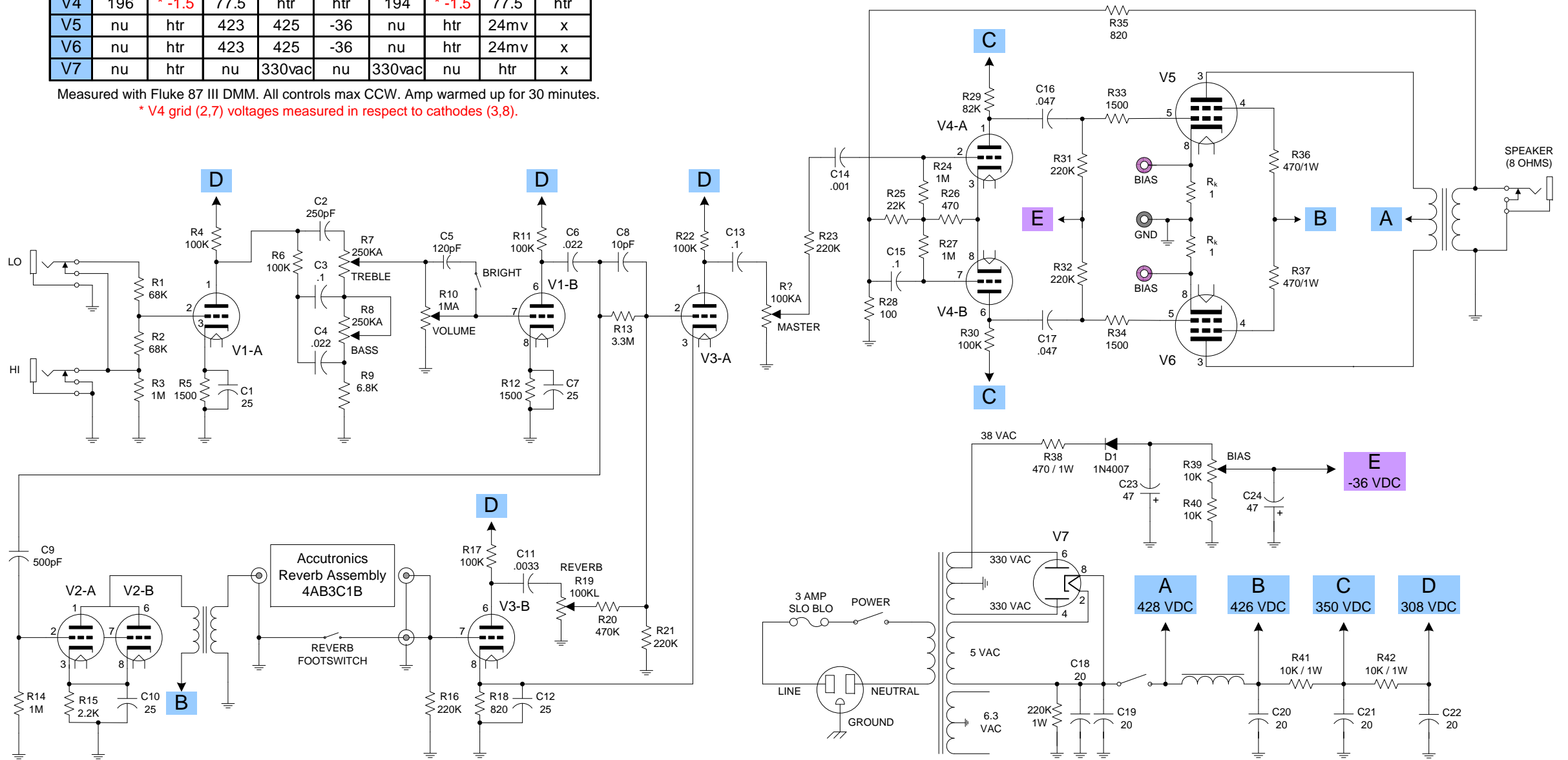

TWEED DELUXE REVERB designed by Steve Luckey. (2006)

Schematic is based on Fender Deluxe Reverb AB763 circuit.

