

# Commercial Instrument Amplifiers

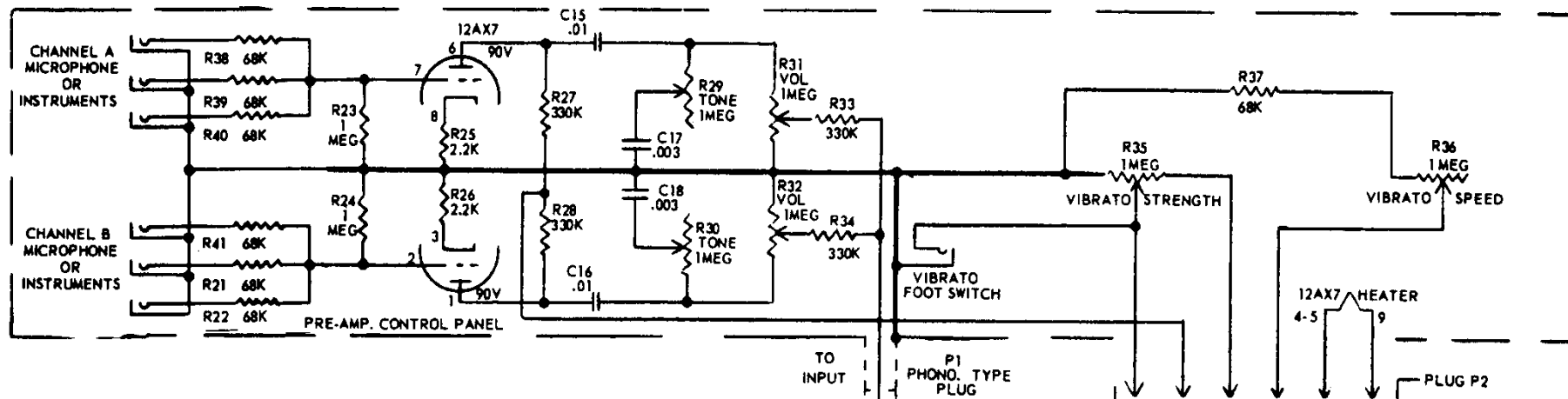

## NOTES:

1. VALUES OF CAPACITORS IN MFD.
2. ALL RESISTORS ARE 1/2 WATT UNLESS OTHERWISE NOTED.
3. VOLTAGES MEASURED FROM POINTS INDICATED TO CHASSIS WITH 20,000 OHM/VOLT METER.

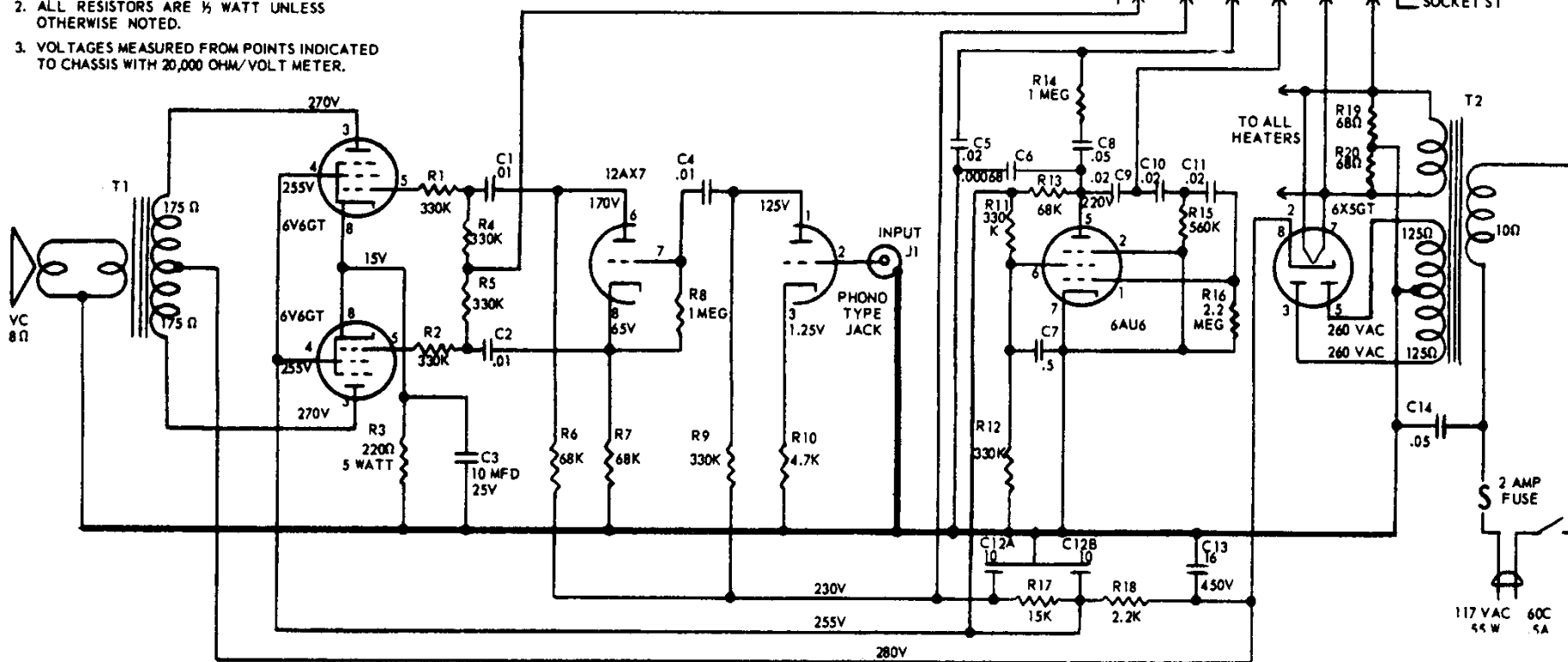

Wards Airline Model GDR-8503A, 8504A

# Airline 8504 Cascode Mod

*Sluckey 01/24/2019*

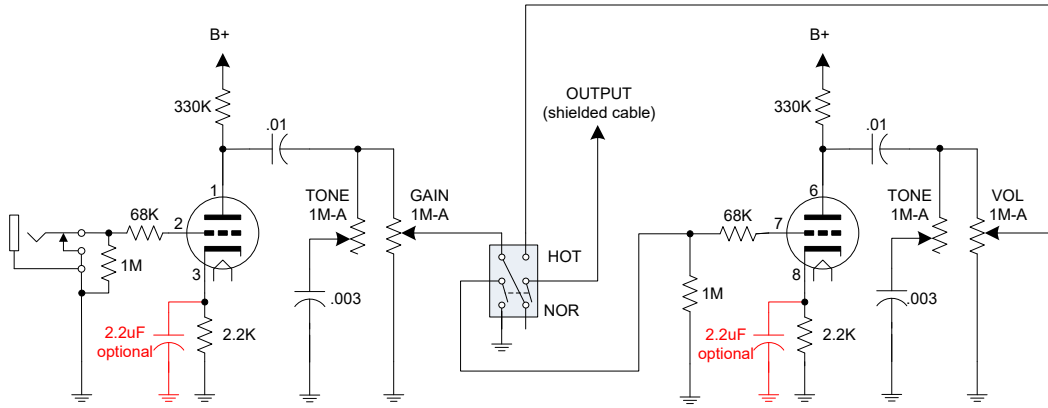

Switchcraft 12A

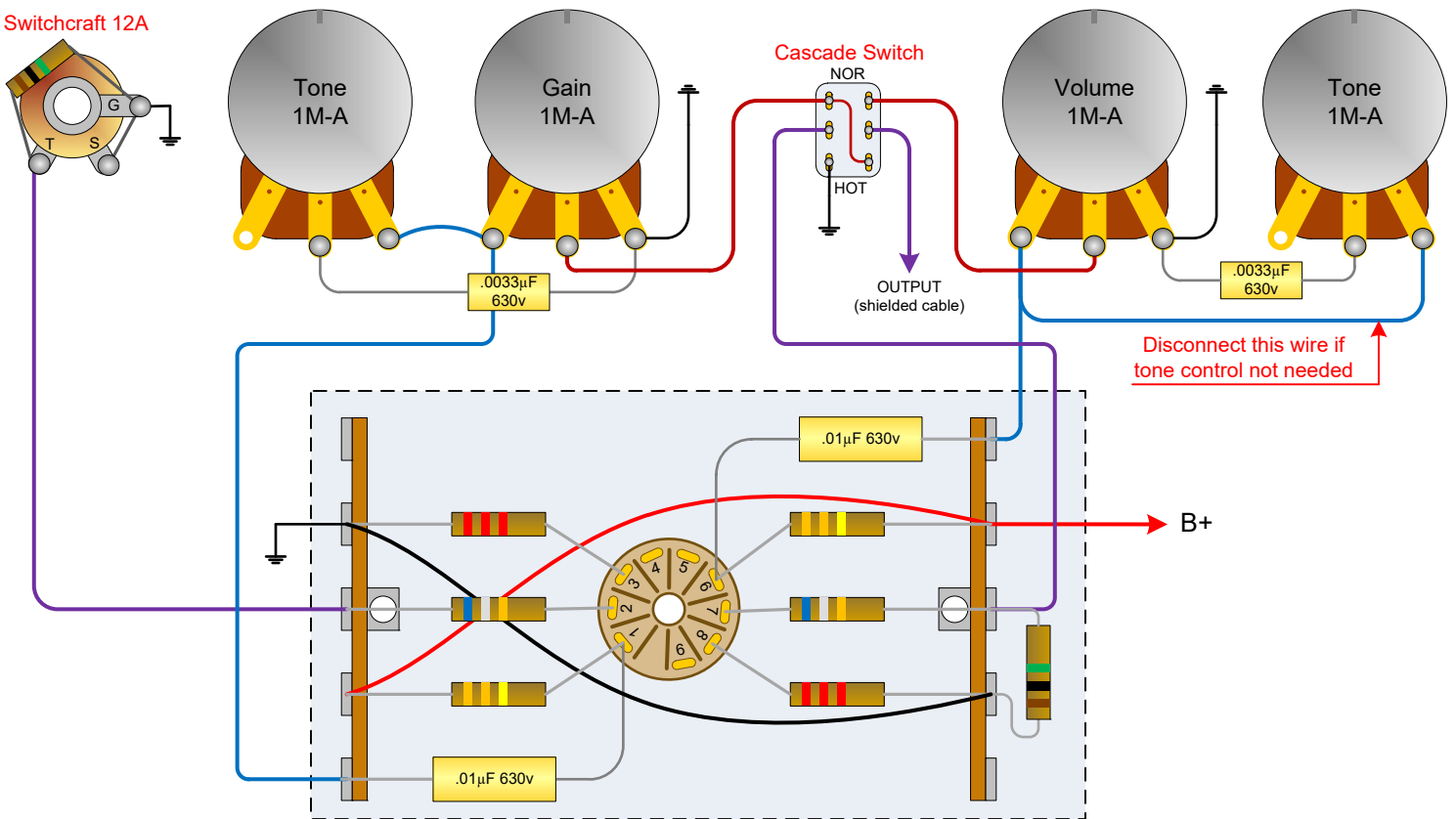

Disconnect this wire if tone control not needed

This red wire should connect here

This 1M resistor relocated to input jack

This black wire should connect here

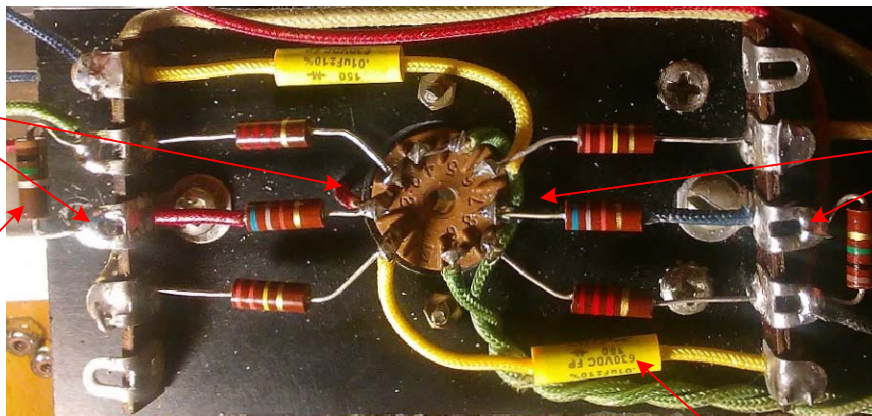

This cap and connecting wire are too close to heater wires and could be a source of filament hum. Flip both caps to correct.