

BOGEN-PRESTO

DESIGNED BY HENRY MARSHALL & L. A. BOGSON OF THE SIGWELL CORPORATION

B
P



OPERATING INSTRUCTIONS

MODEL VP 20

BOGEN-PRESTO MODEL VP20 TRANSCRIPTION PLAYER PORTABLE P.A. SYSTEM

DESCRIPTION

The model VP20 is a portable transcription player—20 watt public address system. It is ideal for school use, square dances, calisthenics and all other applications requiring a four speed record player plus a P.A. system.

The record player is a Bogen Model B50-16 precision-built, time-proven transcription player with variable speed control from 29 through 86 rpm. It has instant speed selection of 16, 33-1/3, 45 and 78 rpm. The phono cartridge is a G.E. variable reluctance unit with dual sapphire-tipped styli. In addition the record player features a heavy-duty 4 pole motor, rubber-padded turntable accommodating up to 16" diameter discs, feather-drop action device which lifts tone arm and sets it down on record for maximum record and stylus protection and unique, simple-to-use cueing feature. Wow, hum and rumble is negligible.

The amplifier provides 20 watts peak power output with

high fidelity performance. Inputs are provided for 2 microphones and a radio tuner. Outputs are provided for tape recorder and monitor. Speaker outputs are provided for the speaker included in the VP20 case plus the Bogen Model SCC-12 dual-speaker enclosure. The speaker sockets are of the lock-in type. Compensated preamplifier includes separate volume controls for each input, scratch filter, treble and bass controls, auxiliary power outlet, separate master power switch, front panel fuse, illuminated chrome panel and calibrated control knobs.

The speaker, record player and amplifier are housed in a single, attractive portable case. The loudspeaker is a heavy-duty 12" unit mounted in the removable cover. 25 feet of interconnecting cable is provided. The case is handsomely styled, rugged and covered with water and stain resistant vinyl fabric.

SPECIFICATIONS

Power Output — 20 Watts (peak)

Power consumption — Amplifier 76 Watts
Phonograph 12 Watts
Total 88 Watts @ 117 volts, 60 cycle

Inputs — Phono (internal connection), Radio tuner (or tape recorder), 2— high impedance microphones

Outputs — 2— speaker outputs, (8 Ω for 1 SPKR; 2.5 Ω for 3 SPKRS) tape recorder output and monitor output, Auxiliary power receptacle.

Speaker — 12" heavy duty, mounted in detachable cover.

Controls — Master Power, Bass, Treble, Volume Input 2, Volume, Scratch Filter and Input 2 Selector

Tubes — 2—12AX7/ECC83, 12AU7, 2—6BQ5/EL84, EZ81

Pilot Lights — 2—#51

Fuse — 1—1 Amp slo-blo

Dimensions — 16½" x 15¼" x 12¼" (less handle and projections).

Carrying case finish — Grey and Black vinyl fabric.

ACCESSORIES & MICROPHONES

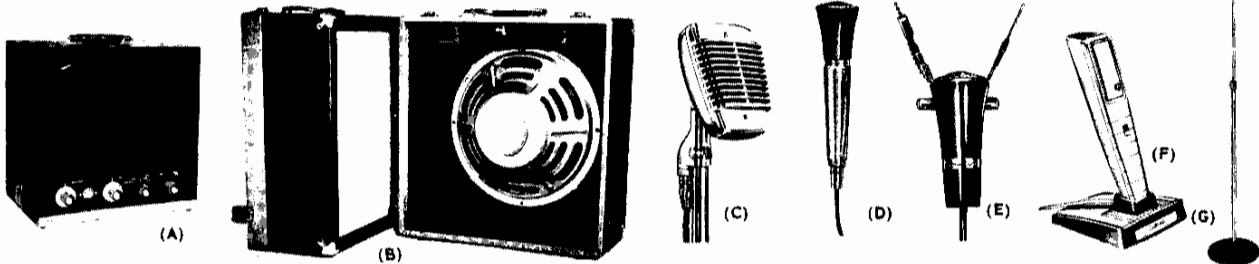

(A) **MON-1 MONITOR AMPLIFIER SYSTEM:** easily connected to Monitor Output of VP20, it ensures caller's clearly hearing music over normal high voice level of square dancers (caller's voice is not amplified by monitor system). Includes a 10 watt, high gain amplifier with the exclusive SelectTone Control providing settings for four different frequency response curves . . . also an 8" Alnico PM speaker mounted in a portable carrying case. 13" x 13" x 9" deep.

(B) **SCC-12 SPEAKER CASE:** portable "break-a-part" dual speaker system forms two separate speaker units. It provides total of three loudspeakers. Comes complete with 25 feet of connecting cable for each speaker. 16" x 15¼" x 11½" deep. 18 pounds. In matching grey vinyl.

(C) **BOGEN-SHURE 555 CARDIOID** — Widely used uni-directional, general purpose, dynamic microphone. Has 3-position impedance switch (50,200,high); 18-ft. 2-conductor shielded cable. 50-15,000 cps. "Positive action" swivel.

(D) **BOGEN-SHURE 430 CONTROLLED MAGNETIC** — General purpose omni-directional microphone. Easily changes from high to low impedance. Has press-to-talk switch (normally closed); 60-10,000 cps; 15-ft. 2-conductor cable; swivel adapter. Use in hand or on floor or table stand.

(E) **BOGEN-SHURE 420 LAVALIER TYPE** — Similar to model 430 but with lavalier cord and clip assembly. Readily detachable, can be hand held. No press-to-talk switch or swivel adapter. Complete with 20-ft. 2-conductor cable. Easy built-in facility for high to low impedance change.

(F) **BOGEN-ELECTRO-VOICE 927 OMNI-DIRECTIONAL CRYSTAL** — For hand use or mounts in own slip-in stand. High impedance, 60-8,000 cps. With 5-ft. single-conductor shielded cable. Fine for general use.

(G) **BOGEN H10 FLOOR STAND** — Sturdy 10" diameter gray wrinkle base; adjustable from 35" to 63". Heavy brass tubing, finished in polished chrome.

INSTALLATION

CONNECTIONS

INPUT

Power Cord: The power cord should be inserted into a power receptacle providing 110 volts, 60 cycles AC. The phono player power is internally connected to a power receptacle on the rear of the amplifier chassis. Disconnection should not be necessary unless the amplifier is removed from cabinet for service.

Microphone Input: Two receptacles, labelled MIC 1 INPUT and MIC 2 INPUT, located on the front panel, are provided for connecting two high impedance type microphones to the VP20.

Radio Tuner Input: A receptacle, labelled RADIO INPUT, located on the front panel, is provided for connecting the output of a tuner to the VP20. If desired any other signal source (e.g. tape recorder output) capable of delivering approximately $\frac{1}{2}$ volt into a high impedance load, may be connected to this input. When this input is used, the phono and MIC 2 inputs are automatically disconnected.

Phono Input: The phono signal input connector is located on the top of the VP20 chassis and is a connection internal to the unit. Disconnection should not be necessary unless amplifier unit is removed from cabinet for service.

OUTPUT

Speaker Output: Two speaker output receptacles are provided on the front panel. One receptacle (labelled "1") is used to connect the speaker mounted in the VP20 removable cover. The other receptacle (labelled "#3"), is used to connect the Bogen model SCC-12 dual speaker-enclosure to the VP20. Any speaker system having an impedance of 8 ohms, may be connected to SPEAKER #3 receptacle. The second speaker system may be operated up to 300 feet from the VP20. Cable runs of over 50 feet should be made with #14 wire or larger to minimize output power losses.

When using the VP20 system in conjunction with the Bogen-Presto model SCC-12 Dual-Speaker system connect

the speakers as follows. Remove the VP20 connector from the receptacle labelled "Speakers #1" on front panel of VP20. Insert the connector into the receptacle on one of the SCC-12 speaker cabinet sections. Insert the connector from this speaker cabinet section into the receptacle on the other SCC-12 speaker cabinet section. Insert the connector from this speaker cabinet section into the receptacle, on the front panel of the VP20 labelled "Speakers #3". This arrangement provides the correct impedance match between speakers and amplifier while providing maximum interconnecting cable length for placement convenience.

Tape Output: Program material (phono MIC #2 or radio) may be recorded on a tape recorder. Connect the high impedance input of the tape recorder to the jack labelled TAPE OUT, on the front panel.

Monitor Output: A low level signal output of the phono or mic #2 signal is available at the output jack labelled MONITOR. The monitor output may be connected to a separate monitor amplifier having a high impedance input. This provision is specifically designed for use in applications such as square dancing where the "caller" wishes to hear the musical accompaniment only.

When using the VP20 system in conjunction with the Bogen-Presto model MON-1 Monitor-Amplifier system interconnect the units as follows. A patch cord, having phono type connectors on both ends, is provided with the MON-1 system. Insert one connector into the receptacle, on the front panel of the VP20, labelled "Monitor" and the other connector into the receptacle, on the rear of the MON-1 amplifier, labelled "Phono". The control, labelled "Phono" on the front of the amplifier is now used to control the loudness level of the MON-1 system.

Auxiliary Power Outlet: This receptacle, located on front panel and labelled 2.2 AMP MAX, can supply power to associated equipment (e. g. radio tuner). Be sure that any auxiliary unit plugged into this outlet does not draw more than 2.2 amperes. The master power switch of the VP20 controls the power available at this receptacle. Hence the power to the VP20 and auxiliary unit can be controlled in unison.

OPERATION

CONTROL FUNCTIONS

MASTER POWER SWITCH - Used to turn VP20 and any equipment connected to the auxiliary power outlet, on and off. This switch does not control power to turntable. The turntable must be shut off by using the phono power switch on the phonograph. Never turn power off by any other means, as flat spots may be formed on the phono drive wheel.

BASS - Used to control the bass response of the phono or mic #2 signal inputs. It does not affect the mic #1 input. Rotating the control to the maximum counterclockwise position produces a flat bass response. Rotating the control to the maximum clockwise position provides maximum accentuation (boost) of the bass frequencies. The control is continuously variable to produce any desired bass response between the two extremes.

TREBLE - Used to control the treble response of the

phono or mic #2 signal inputs. It does not affect the mic #1 input. Rotating the control to the maximum clockwise position produces a flat treble response. Rotating the control to the maximum counterclockwise position provides maximum attenuation (cut) of the treble frequencies. The control is continuously variable to produce any desired treble response between the two extremes.

VOLUME INPUT 2 - Used to control the volume level of the phono, mic #2 or radio signals (depending upon which input is being used). Clockwise rotation of the control increases the amplifier output.

VOLUME MIC 1 - Used to control the volume level of the microphone input #1 signal. Clockwise rotation of the control increase the amplifier output. If no microphone is connected to the MIC 1 INPUT then the control is inoperative.

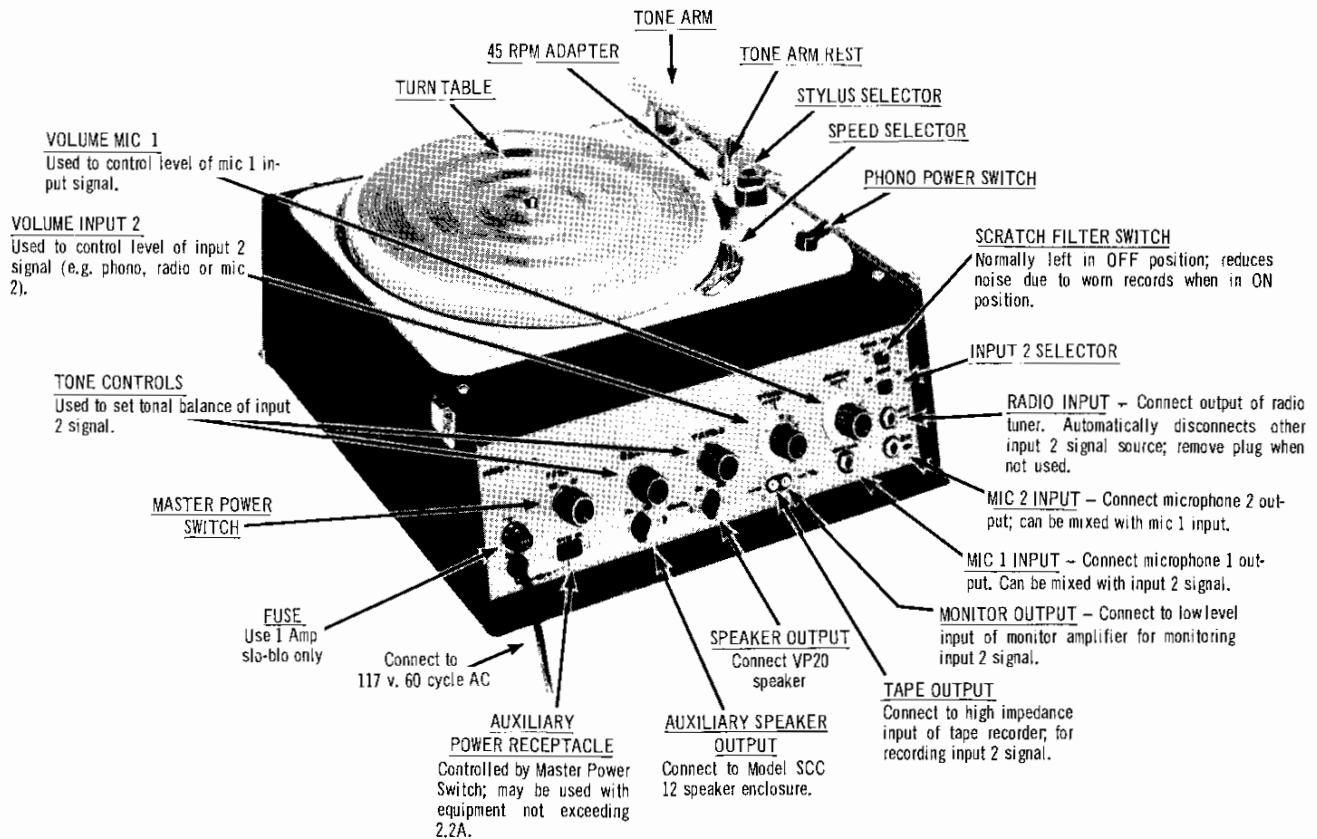

Figure 1 - Front view of VP20 Amplifier and Phono mechanism

the maximum clockwise position provides maximum accentuation (boost) of the bass frequencies. The control is continuously variable to produce any desired bass response between the two extremes.

TREBLE - Used to control the treble response of the phono or mic #2 signal inputs. It does not affect the mic #1 input. Rotating the control to the maximum clockwise position produces a flat treble response. Rotating the control to the maximum counterclockwise position provides maximum attenuation (cut) of the treble frequencies. The control is continuously variable to produce any desired treble response between the two extremes.

VOLUME INPUT 2 - Used to control the volume level of the phono, mic #2 or radio signals (depending upon which input is being used). Clockwise rotation of the control increases the amplifier output.

VOLUME MIC 1 - Used to control the volume level of the microphone input #1 signal. Clockwise rotation of the control increase the amplifier output. If no microphone is connected to the MIC 1 INPUT then the control is inoperative.

SCRATCH FILTER - If, when playing a disc recording, needle scratch noise is excessive due to a worn or old record, move the switch to the ON position. Normally, this control should be in the OFF position to retain full reproduction fidelity.

RECORD PLAYER OPERATION

1. Turn on VP20 using MASTER POWER SWITCH. Allow a few seconds for amplifier to warm-up.

2. Select the proper stylus for record being played. For microgroove recordings (16, 33-1/3 and 45 rpm) push down the STYLUS SELECTOR KNOB (red knob on top of record player tone arm) and rotate so that LP marking is facing front of tone arm. For standard groove (78 rpm) and transcription (33-1/3 rpm) recordings, push down STYLUS SE-

LECTOR KNOB and rotate so that 78 marking is facing front of tone arm.

3. Set SPEED SELECTOR KNOB for speed of recording to be played. The speed of the motor is adjustable for 16, 33-1/3, 45 and 78 rpm recordings and is also continuously variable from 29 to 86 rpm for special applications. The basic speeds are available by setting the SELECTOR KNOB in the notched positions. By moving the lever out of and between notches, the record may be played slower or faster than normal; this may be desirable, for example, in playing music with a fast tempo slower than usual, for dance instruction.

4. Place the disc recording on the turntable and set the tone arm so that the stylus is directly over the entering groove of the record.

5. Turn the record player control knob (figure 2) until a "click" is felt and allow a few seconds for turntable to

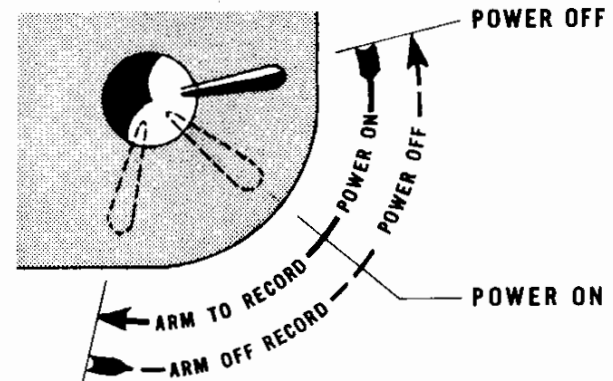

Figure 2 - Phonograph Power Switch

reach full speed. Continue to rotate knob clockwise until stylus is gently set down on to record.

6. Adjust the VOLUME INPUT 2, BASS and TREBLE controls for the desired loudness and tonal balance.

7. When record has finished, turn record player control knob counterclockwise to lift tone arm and continue rotation until phono motor is shut off (refer to figure 2). NOTE: Never turn power off by any other means, as flat spots may be formed on the phono drive wheel.

8. Lift tone arm and place it on its rest post.

RADIO TUNER OPERATION

1. Turn on VP20 using MASTER POWER SWITCH. Allow a few seconds for amplifier to warm-up.

2. Insert the plug on the end of the radio tuner cable into the receptacle labelled RADIO INPUT. This automatically disconnects the phono input.

3. Adjust the VOLUME INPUT 2, BASS and TREBLE controls for the desired loudness and tonal balance.

NOTE: When it is desired to return to phono operation, the plug from the radio tuner must first be removed from its receptacle on the VP20.

TAPE RECORDER OR OTHER INPUT OPERATION

For reproduction of a tape recording or signal from any other source through the VP20 follow the instructions as given above for radio tuner operation.

To record, on a tape recorder, the signal being dis-

tributed by the VP20, proceed as follows. Adjust the VP20 as described in the respective section for the signal source being used. Insert the input cable plug of the tape recorder into the receptacle labelled TAPE OUT. Adjust the tape recorder controls as described in the instruction manual accompanying the unit. Note: The signal level and tonal characteristics of the signal present at the TAPE OUT receptacle is affected by all the controls in the VP20.

MICROPHONE OPERATION

Two separate microphones may be connected to the VP20 simultaneously by inserting the microphone cable plugs into the receptacles labelled MIC 1 INPUT and MIC 2 INPUT. Move the INPUT 2 SELECTOR SWITCH to the MIC 1 position. In this case, the microphone connected to the MIC 1 INPUT is controlled by using the VOLUME MIC 1 control. The microphone connected to the MIC 2 INPUT is controlled by using the VOLUME INPUT 2, BASS and TREBLE controls. Note: The BASS and TREBLE controls have no effect on the MIC 1 INPUT signal.

If it is desired to use one microphone and another signal source (e.g. radio tuner or phono) then connect the microphone to the MIC 1 INPUT, set the INPUT 2 SELECTOR SWITCH to the PHONO position, and adjust the controls for the desired signal balance.

NOTE: If the speaker(s) are located too close to the microphone, acoustic feedback (squealing) may result in the speaker output. The volume should be set lower and/or the distance between the speaker(s) and the microphone should be increased until the feedback is eliminated.

RECORD PLAYER SERVICE

ARM LIFT BAR HEIGHT ADJUSTMENT

1. With master power switch off, turn the power switch (located in front-right corner) to the full ON (clockwise) position.
2. Set the stylus in the last groove (nearest the center).
3. Loosen the lift bar thumbscrew and adjust the lift bar, which extends under the pickup arm, so that it is about 1/16" lower than the pickup arm.
4. Tighten the thumbscrew securely, making sure to preserve the 1/16" clearance between the lift bar and the pickup arm.

STONE ARM WEIGHT ADJUSTMENT

The tone arm has been preadjusted at the factory and should not be disturbed. The tone arm is factory adjusted to 8-10 grams. (NOTE: The magnetic attraction of the cartridge to the turntable is included in the measurement.) To adjust the tone arm weight, turn the balance screw (at rear end of the tone arm) clockwise to tighten, counterclockwise to increase needle pressure (as viewed from the rear).

STYLUS REPLACEMENT

To replace either stylus, available from any electronics parts distributor or record shop under numbers RPX050 (sapphire) RPX052 (diamond), press knob downward and turn slightly. Hold in this position. Slide the stylus out horizontally and replace it with a new one.

To replace the stem, remove the knob and the two screws holding the cartridge in the head. Pull the 2 lead wire lugs off the pins and remove the cartridge. Press the spring downward and remove the C-shaped clips. Remove the stem and replace it with a new one.

SPEED TESTING AND ADJUSTING

All units are tested and adjusted at the factory. No further adjustment should be required; however, if adjustment is required for any reason, proceed as follows:

1. Set speed selector lever at appropriate position.
2. Place record on turntable.
3. Set the strobe disc on record (the circular disc with radial black lines).

4. Plug the power cord into any 110-120 volt 60 cycle AC power source.
5. Turn power-switch on.
6. Set needle on first grooves of record.
7. Test speed accuracy by checking the strobe pattern which corresponds with the speed selected. (Use fluorescent light if possible: the pattern will be much clearer.) If pattern seems to be moving, adjust speed in the following manner:
 - a. Loosen the speed step-groove screw one or two turns.
 - b. With the speed selector lever in the step-groove, move the step-groove carefully until the appropriate strobe disc pattern seems to be stationary.
 - c. Carefully lift the speed selector lever out of the step-groove without moving the step, and tighten the screw.
 - d. Repeat this procedure for each speed setting which needs adjustment.

LUBRICATION

The bearing on the rotor side of the motor can be lubricated by removing the rectangular cover held down by two screws, pouring 3 drops maximum of fine oil onto the felt and replace cover.

All other points are lubricated for the life of the unit. Under normal use, it should not be necessary to lubricate the motor more than once every five years.

When lubricating the B50-16 record player, be sure to avoid excess oil on other parts — especially the idler wheel rim and the motor conical drive shaft.

SERVICING

Some of the trouble that may be experienced, and suggested remedies, follow:

A. TURNTABLE DOESN'T ROTATE

1. MOTOR TURNS

- a. Idler wheel rim (A) damaged: replace the assembly.
- b. Idler arm spring (B) lost or damaged: replace.

(continued on page 6)

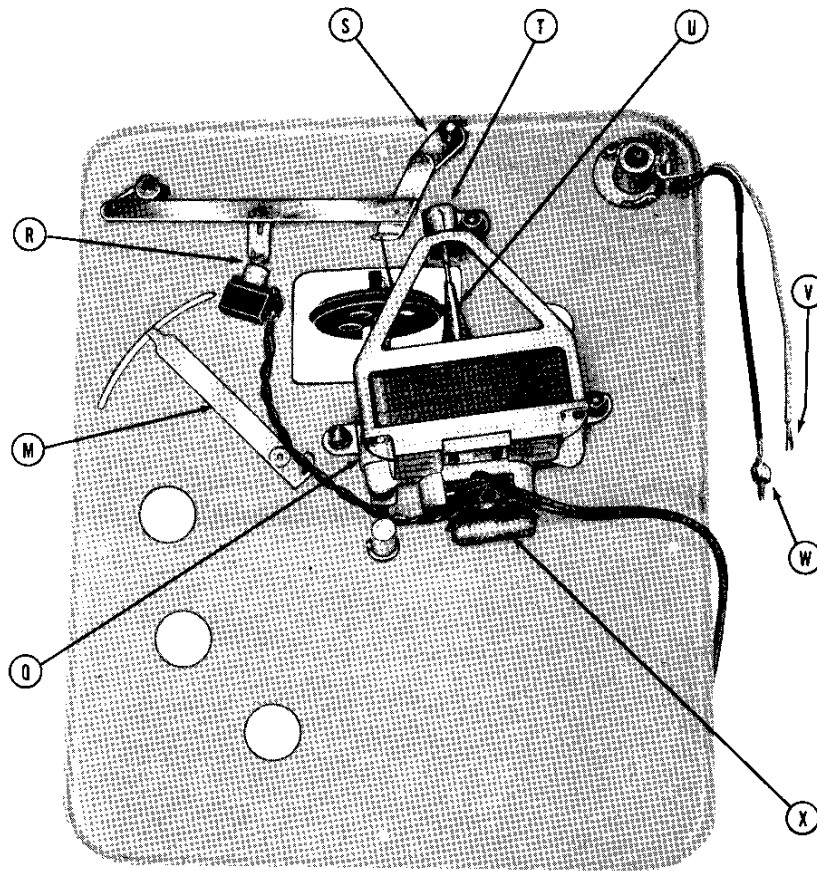

Figure 3 – Bottom view of Record Player, removed from cabinet

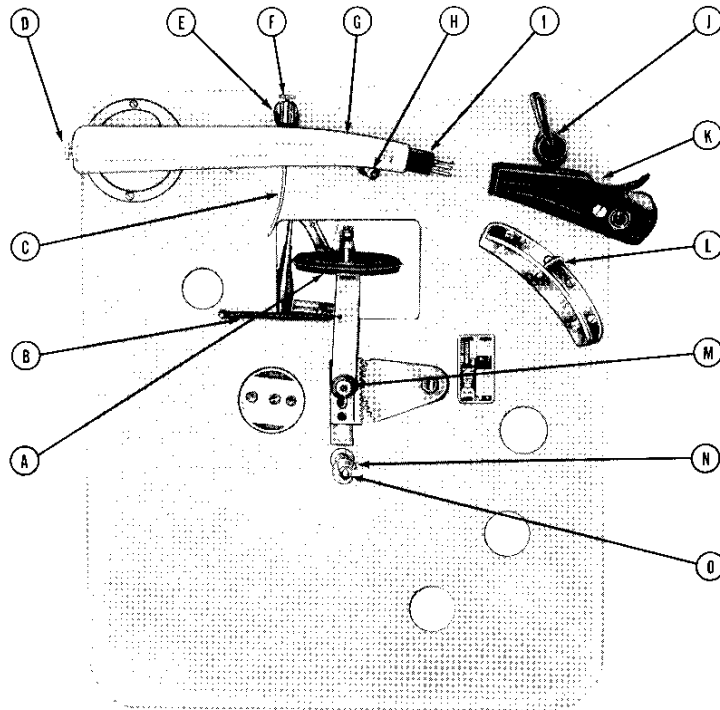

Figure 4 – Top view of Record Player, Turntable removed

reach full speed. Continue to rotate knob clockwise until stylus is gently set down on to record.

6. Adjust the VOLUME INPUT 2, BASS and TREBLE controls for the desired loudness and tonal balance.

7. When record has finished, turn record player control knob counterclockwise to lift tone arm and continue rotation until phono motor is shut off (refer to figure 2). NOTE: Never turn power off by any other means, as flat spots may be formed on the phono drive wheel.

8. Lift tone arm and place it on its rest post.

RADIO TUNER OPERATION

1. Turn on VP20 using MASTER POWER SWITCH. Allow a few seconds for amplifier to warm-up.

2. Insert the plug on the end of the radio tuner cable into the receptacle labelled RADIO INPUT. This automatically disconnects the phono input.

3. Adjust the VOLUME INPUT 2, BASS and TREBLE controls for the desired loudness and tonal balance.

NOTE: When it is desired to return to phono operation, the plug from the radio tuner must first be removed from its receptacle on the VP20.

TAPE RECORDER OR OTHER INPUT OPERATION

For reproduction of a tape recording or signal from any other source through the VP20 follow the instructions as given above for radio tuner operation.

To record, on a tape recorder, the signal being dis-

tributed by the VP20, proceed as follows. Adjust the VP20 as described in the respective section for the signal source being used. Insert the input cable plug of the tape recorder into the receptacle labelled TAPE OUT. Adjust the tape recorder controls as described in the instruction manual accompanying the unit. Note: The signal level and tonal characteristics of the signal present at the TAPE OUT receptacle is affected by all the controls in the VP20.

MICROPHONE OPERATION

Two separate microphones may be connected to the VP20 simultaneously by inserting the microphone cable plugs into the receptacles labelled MIC 1 INPUT and MIC 2 INPUT. Move the INPUT 2 SELECTOR SWITCH to the MIC 2 position. In this case, the microphone connected to the MIC 1 INPUT is controlled by using the VOLUME MIC 1 control. The microphone connected to the MIC 2 INPUT is controlled by using the VOLUME INPUT 2, BASS and TREBLE controls. Note: The BASS and TREBLE controls have no effect on the MIC 1 INPUT signal.

If it is desired to use one microphone and another signal source (e.g. radio tuner or phono) then connect the microphone to the MIC 1 INPUT, set the INPUT 2 SELECTOR SWITCH to the PHONO position, and adjust the controls for the desired signal balance.

NOTE: If the speaker(s) are located too close to the microphone, acoustic feedback (squealing) may result in the speaker output. The volume should be set lower and/or the distance between the speaker(s) and the microphone should be increased until the feedback is eliminated.

RECORD PLAYER SERVICE

ARM LIFT BAR HEIGHT ADJUSTMENT

1. With master power switch off, turn the power switch (located in front-right corner) to the full ON (clockwise) position.
2. Set the stylus in the last groove (nearest the center).
3. Loosen the lift bar thumbscrew and adjust the lift bar, which extends under the pickup arm, so that it is about 1/16" lower than the pickup arm.
4. Tighten the thumbscrew securely, making sure to preserve the 1/16" clearance between the lift bar and the pickup arm.

TONE ARM WEIGHT ADJUSTMENT

The tone arm has been preadjusted at the factory and should not be disturbed. The tone arm is factory adjusted to 8-10 grams. (NOTE: The magnetic attraction of the cartridge to the turntable is included in the measurement.) To adjust the tone arm weight, turn the balance screw (at rear end of the tone arm) clockwise to tighten, counterclockwise to increase needle pressure (as viewed from the rear).

STYLUS REPLACEMENT

To replace either stylus, available from any electronics parts distributor or record shop under numbers RPX050 (sapphire) RPX052 (diamond), press knob downward and turn slightly. Hold in this position. Slide the stylus out horizontally and replace it with a new one.

To replace the stem, remove the knob and the two screws holding the cartridge in the head. Pull the 2 lead wire lugs off the pins and remove the cartridge. Press the spring downward and remove the C-shaped clips. Remove the stem and replace it with a new one.

SPEED TESTING AND ADJUSTING

All units are tested and adjusted at the factory. No further adjustment should be required; however, if adjustment is required for any reason, proceed as follows:

1. Set speed selector lever at appropriate position.
2. Place record on turntable.
3. Set the strobe disc on record (the circular disc with radial black lines).

4. Plug the power cord into any 110-120 volt 60 cycle AC power source.
5. Turn power-switch on.
6. Set needle on first grooves of record.
7. Test speed accuracy by checking the strobe pattern which corresponds with the speed selected. (Use fluorescent light if possible; the pattern will be much clearer.) If pattern seems to be moving, adjust speed in the following manner:
 - a. Loosen the speed step-groove screw one or two turns.
 - b. With the speed selector lever in the step-groove, move the step-groove carefully until the appropriate strobe disc pattern seems to be stationary.
 - c. Carefully lift the speed selector lever out of the step-groove without moving the step, and tighten the screw.
 - d. Repeat this procedure for each speed setting which needs adjustment.

LUBRICATION

The bearing on the rotor side of the motor can be lubricated by removing the rectangular cover held down by two screws, pouring 3 drops maximum of fine oil onto the felt and replace cover.

All other points are lubricated for the life of the unit. Under normal use, it should not be necessary to lubricate the motor more than once every five years.

When lubricating the B50-16 record player, be sure to avoid excess oil on other parts — especially the idler wheel rim and the motor conical drive shaft.

SERVICING

Some of the trouble that may be experienced, and suggested remedies, follow:

A. TURNTABLE DOESN'T ROTATE

1. MOTOR TURNS

- a. Idler wheel rim (A) damaged: replace the assembly.
- b. Idler arm spring (B) lost or damaged: replace.

(continued on page 6)

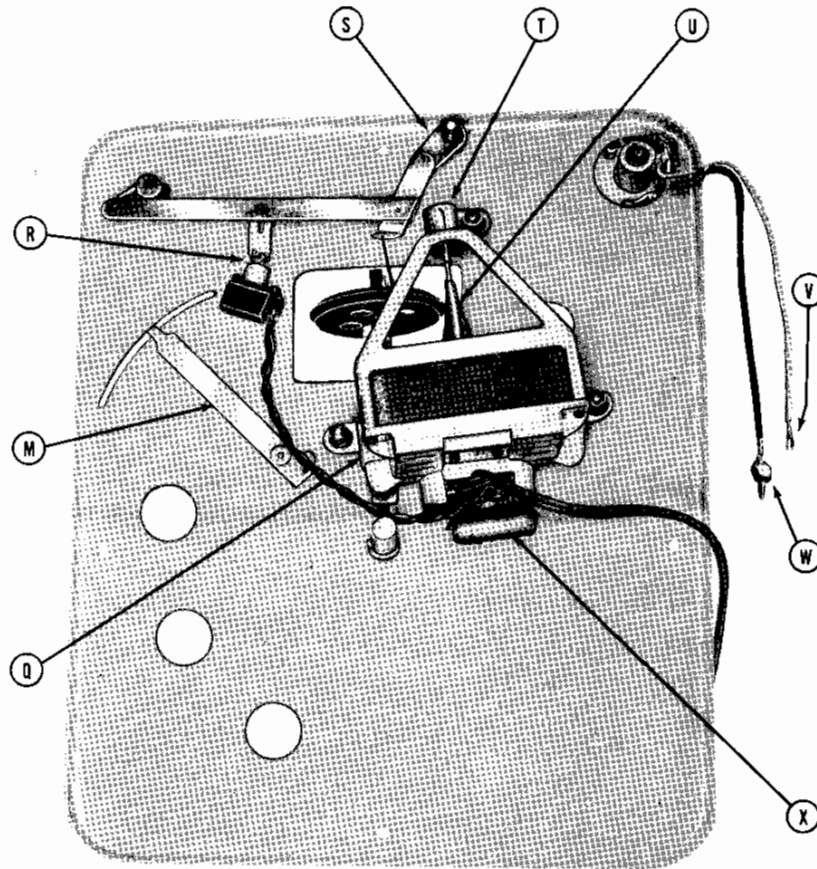

Figure 3 – Bottom view of Record Player, removed from cabinet

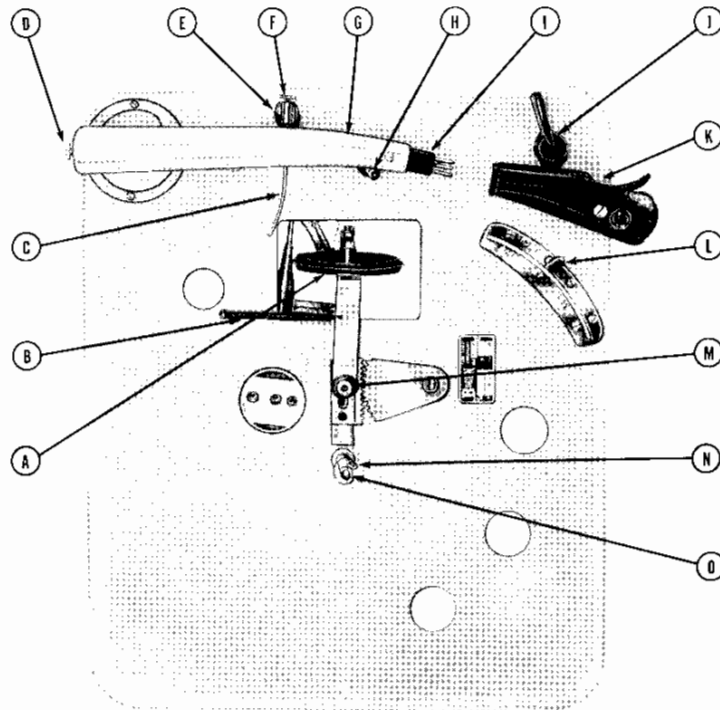

Figure 4 – Top view of Record Player, Turntable removed

2. MOTOR DOESN'T TURN

- Toggle switch (R) turned off under mounting plate without turning the power switch (J). Turn on the toggle switch under the mounting plate.
- Power failure. Check all connections.
- Broken wire in power cable. Splice and solder or replace entire cable.
- Toggle switch (R) broken: replace.
- Motor (Q) burned out: replace.

B. MOTOR WON'T TURN OFF. Capacitor (X) across switch terminals shorted: replace.

C. ERRATIC SPEED (Wow)

- Clean rubber rim of idler wheel thoroughly with denatured alcohol. If oil has been on rubber rim for any length of time or if dented or broken, replace.
- Oil or grease under turntable or on motor drive cone (W). Clean thoroughly with denatured alcohol.

D. SOUND DISTORTED

- Stylus bent: bend so that needle makes true vertical contact with record. Be sure stylus is accurately centered in the slot.
- Needle worn. Replace.
- Tracking pressure too low. Readjust pressure.

REPLACEMENT PARTS

The B50-16 record player is extremely simple and rugged. There are very few parts which should ever require replacement. The following parts list contains those items which may conceivably require replacement due to accident, loss or excessive wear.

KEY	PART NO.	ITEM DESCRIPTION
A	W-1	Idler Wheel Assembly
B	1011-29	Idler Arm Spring
C	1011-30	Arm Lift Bar
D	1011-70	Tone Arm Weight Adj. Screw
E	1011-31	Arm Lift Bar Post Assembly
F	1011-32	Bar Post Set Screw
G	1011-33	Tone Arm
H	1011-34	Tone Arm Rest Post
I	1011-71	Tone Arm Plug
J	1011-36	Power Switch Lever
K	H2	Cartridge Head
L	1011-65	Speed Control Lever
M	1011-66	Idler Assy. Retaining Spring
N	1011-38	Turntable Clip
O	1011-39	Spindle
Q	1011-40	Motor Assembly
R	1011-41	Toggle Switch
S	1011-42	Lift Bar Phenolic Cam
T	1011-67	Motor Spindle Bearing
U	1011-68	Motor Drive Cone
V	1011-69	Spade Lug (Ground)
W	B322	Phono Plug
X	C147	Capacitor
	1011-43	45 rpm Spindle Adaptor
	1011-26HS	High Spring Shockmount Assy
	1011-26LS	Low Spring Shockmount Assy
	1CD	Tone Arm Base Assembly

In ordering replacement parts, be sure to specify the part number and the item description of this model. The letter designations in the first column of the parts list are only to be used for referring to the photos and service directions.

AMPLIFIER SERVICE

FUSE REPLACEMENT

A 1 ampere slo-blo type fuse is located on the front panel. To replace this fuse, press the spring-loaded cap slightly inward, rotate counterclockwise and withdraw the cap and fuse. *Use only a 1 ampere slo-blo type fuse for replacement.* If a second fuse blows, do not make any further attempt to operate the unit. Consult a Bogen representative or other qualified technician for inspection of the unit.

PANEL LIGHT REPLACEMENT

To remove either of the panel light bulbs, remove the shield extending out over the top of the front panel. This is done by removing the two screws, in either end of the shield, and then lifting off the shield. The panel light bulb holders are now readily accessible. To remove the bulb, squeeze both sides of the holder bracket and pull away from the panel. Then press the bulb inward and rotate

counterclockwise slightly. Use #51 bulbs for replacement. To replace the bulb use the reverse procedure.

TUBE REPLACEMENT

The vacuum tubes should be checked at periodic intervals to insure optimum performance. To remove the tubes, remove the shield extending out over the top of the front panel. This is done by removing the two screws, at either end of the shield, and then lifting off the shield.

IF TROUBLE OCCURS

If trouble ever develops with your unit, please do not hesitate to ask our advice or assistance. We are interested in your Bogen unit for as long as you have it. Information can be obtained by writing to: Service Department, Bogen-Presto, P.O. Box 500, Paramus, New Jersey.

When communicating with us give the model number and serial number of your unit. Completely describe the difficulty encountered. Describe the effects each operating con-

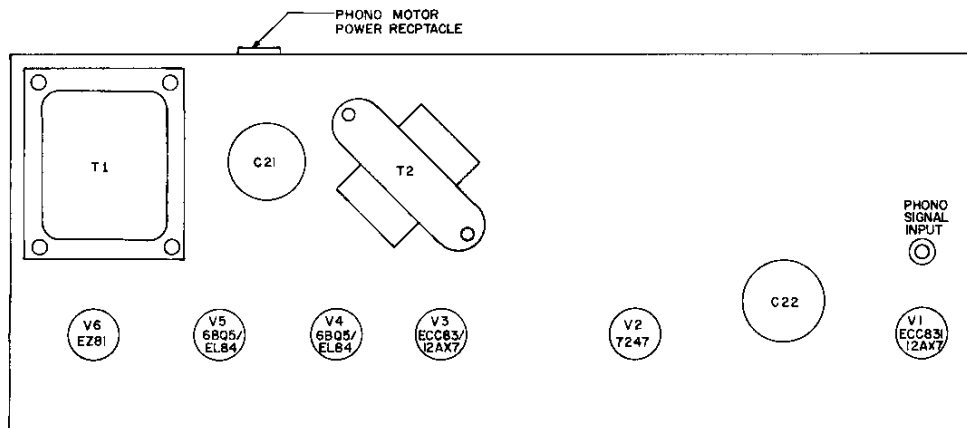

Figure 5 - Top view of Amplifier chassis

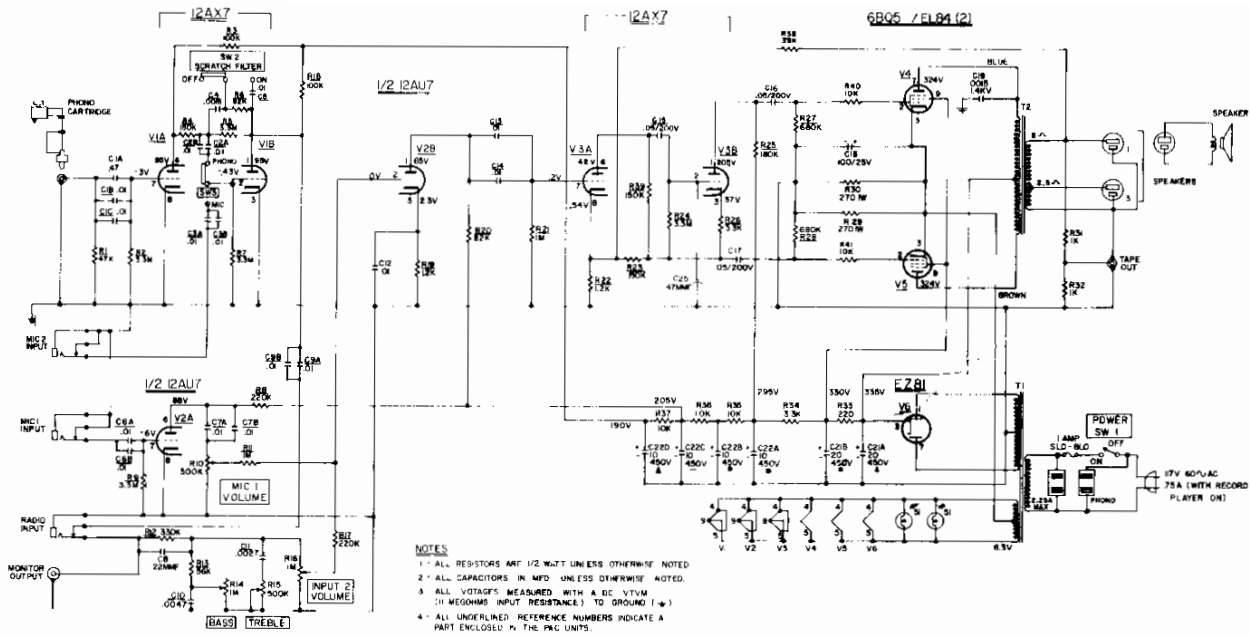

Figure 6 - VP20 Schematic Diagram

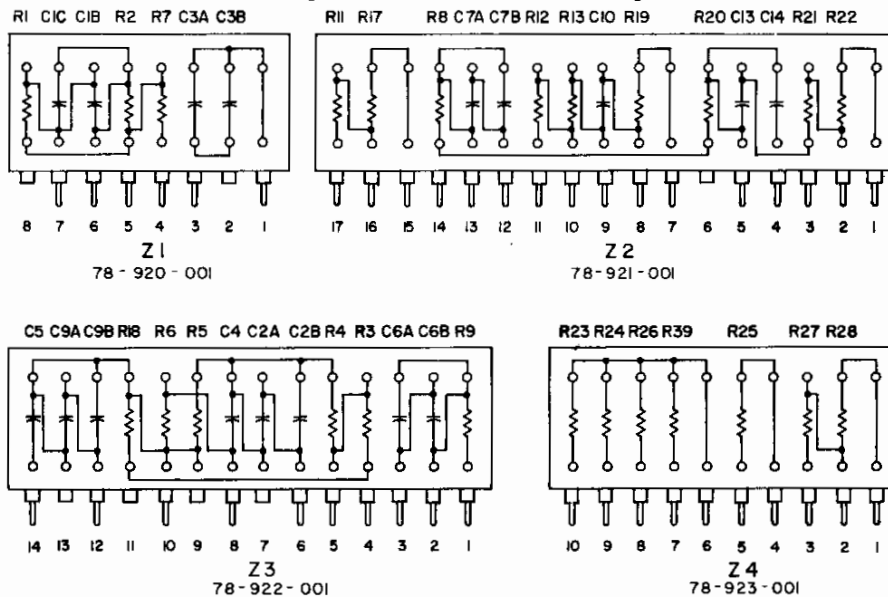

Figure 7 - VP20 Printed Circuit (PAC) Units

trol has upon the symptoms of trouble. Include details on electrical connections to associated equipment and list such equipment.

When we receive this information we will send you service information if the trouble appears to be simple (e.g. bad vacuum tube, incorrect connections). If trouble requires servicing, we shall send you the name and address of the nearest Bogen authorized service agency to which you can send your unit for repair.

When shipping your unit, pack instrument well to prevent damage in transit. Send unit, fully insured and prepaid, via railway express. Do not ship via parcel post unless so instructed. The unit will be promptly repaired and returned to you via express collect.

AMPLIFIER PARTS LIST

R11	77-001-470	Control, Mic 1 Volume
R14	77-001-470	Control, Bass
R15	77-001-367	Control, Treble
R16	77-001-367	Control, Input 2 Volume
C19	C863	Capacitor, ceramic disc, 1500mmf, 1.4KV
C18	79-001-049	Capacitor, electrolytic, 100uf, 25V
C20	C863	Capacitor, ceramic disc, 1500mmf, 1.4KV
C21	79-010-008	Capacitor, electrolytic, 2-20uf, 450V
C22	79-010-015	Capacitor, electrolytic, 4-10uf, 450V
C1	78-200-132	Capacitor, ceramic disc, .47mf, 3V
SW1	81-006-003	Switch, Power on-off
SW2	81-003-010	Switch, Scratch Filter
SW3	81-003-010	Switch, Mic-Phono Selector

(continued on page 8)

AMPLIFIER PARTS LIST (continued)

T1	83-638-000	Transformer, Power	03-0525-01	Knob
T2	83-318-000	Transformer, Audio Output	03-0536-01	Knob Assy, includes scale
Z1	78-920-001	Packaged Circuit	85-0109-01	Plug, Speaker, 2 prong
Z2	78-921-001	Packaged Circuit	26-0026-01	Case, carrying, complete
Z3	89-922-001	Packaged Circuit	93-0011-01	Speaker, 12" PM
Z4	78-923-001	Packaged Circuit		

WARRANTY

The Bogen equipment which you have just purchased has been carefully tested and inspected before leaving our factory. When properly installed and operated in accordance with instructions furnished, it should give excellent performance and reliable operation.

Bogen equipment is guaranteed against all defects in material and workmanship for one year from date of sale to the original purchaser. Any part of the equipment which, under normal installation and use, becomes defective will be repaired or replaced by us, provided it is returned for our examination. Transportation prepaid, to our factory (or authorized service station). This warranty does not apply to equipment which has been subjected to abuse or accident, or which has been altered in any way; nor does this warranty extend to tubes, vibrators, or accessories, etc., not of our own manufacture and which are separately covered by the producing manufacturer's warranty.

The registration card enclosed with the equipment must be filled out and mailed to us within 5 days of purchase to place the warranty in effect.



SOUND SYSTEMS

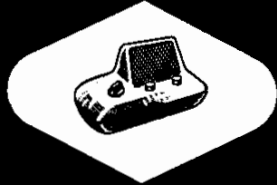
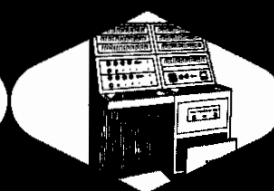

INTERCOMS



HIGH FIDELITY COMPONENTS



PROFESSIONAL EQUIPMENT

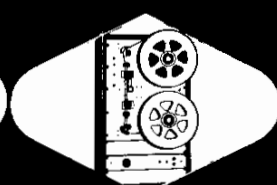

ENGINEERING

PRESTIGE

A DIVISION OF THE **SIEGLER** CORPORATION

P.O. BOX 500, PARAMUS, N.J.