

VOX

NO. V-1-5

VOX AC-15 AMPLIFIER

AMERICAN TUBE NUMBER IN PARENTHESIS

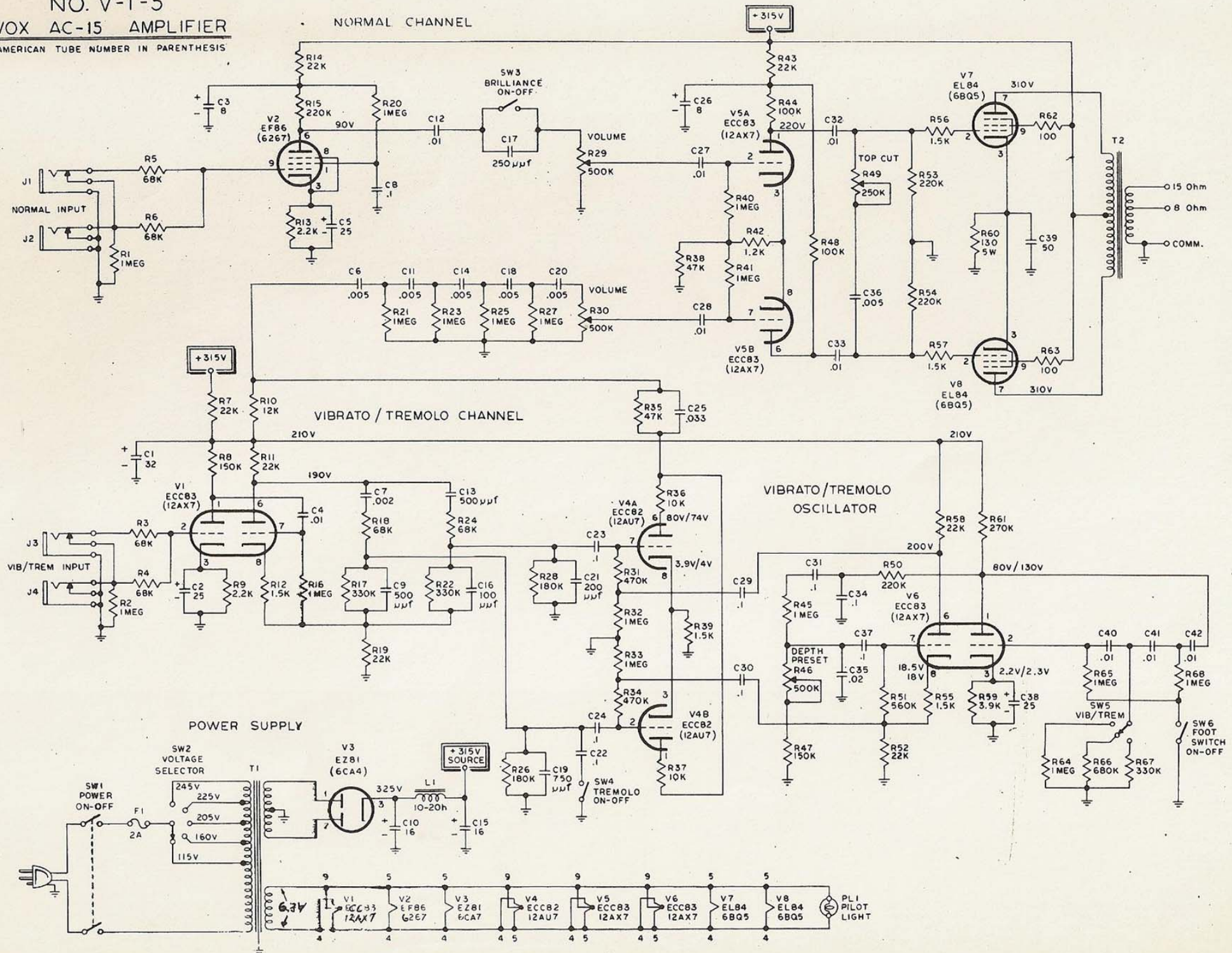

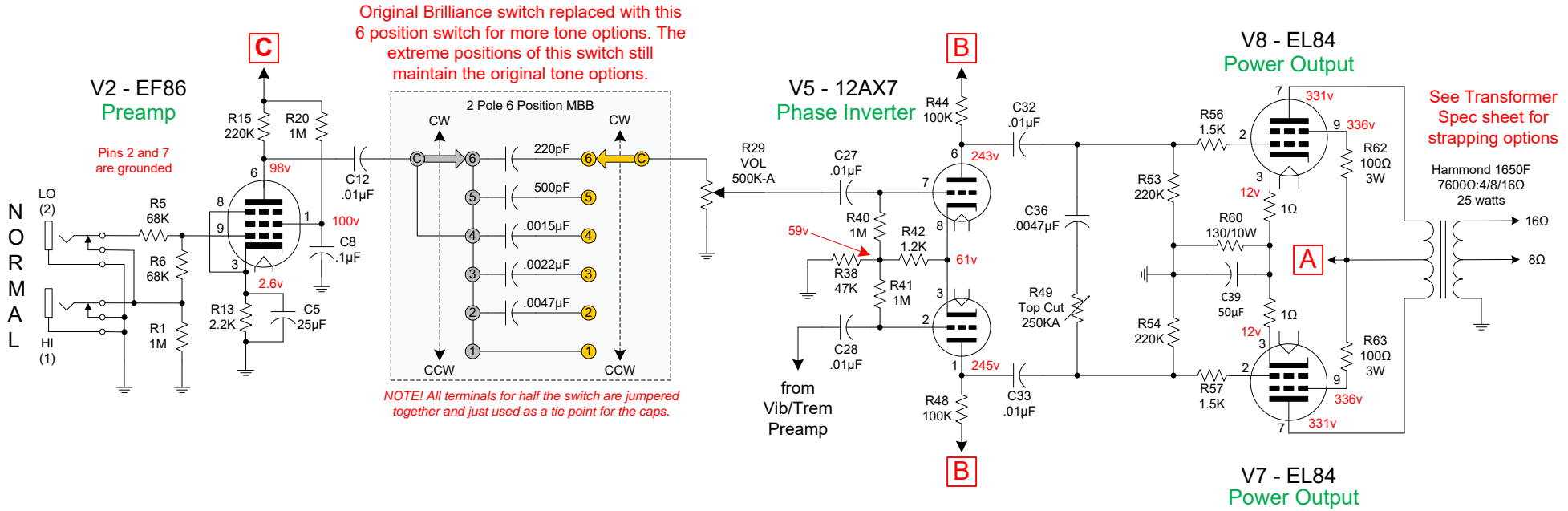

Voltage readings were taken with Fluke 87V.
 Line voltage set to 120VAC with Variac.

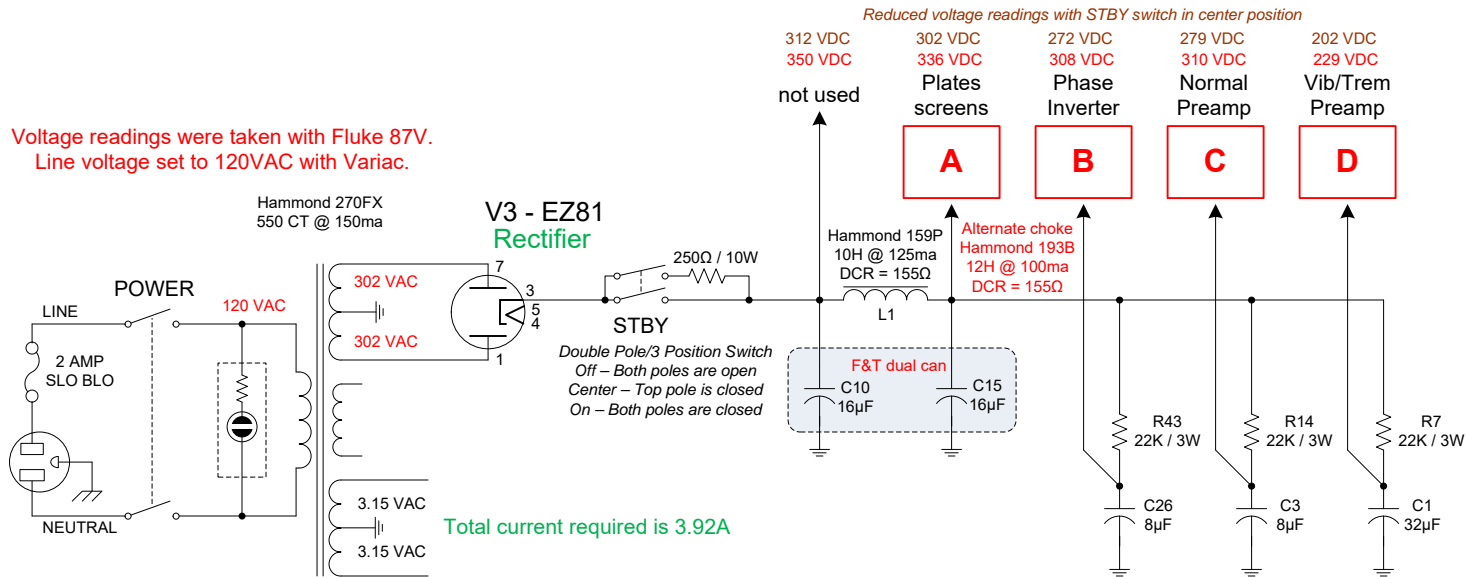

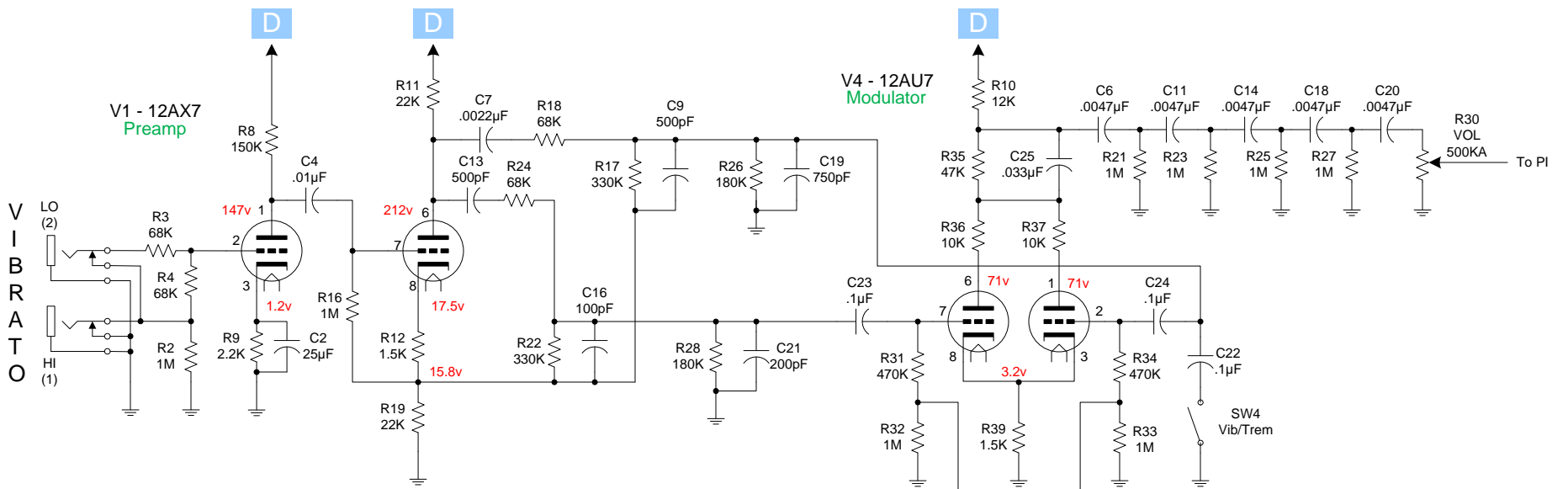

NOTE 1: Oscillator voltages taken with oscillator disabled.

NOTE 2: Speed switch, R64, R66, and R67 replaced with 3M-RA pot and 220K. (See original schematic)

NOTE 3: Depth Preset and R47 replaced with front panel Depth pot. (See original schematic)

NOTE 4: Fast/Slow switch can be a push/pull switch on the DEPTH control.

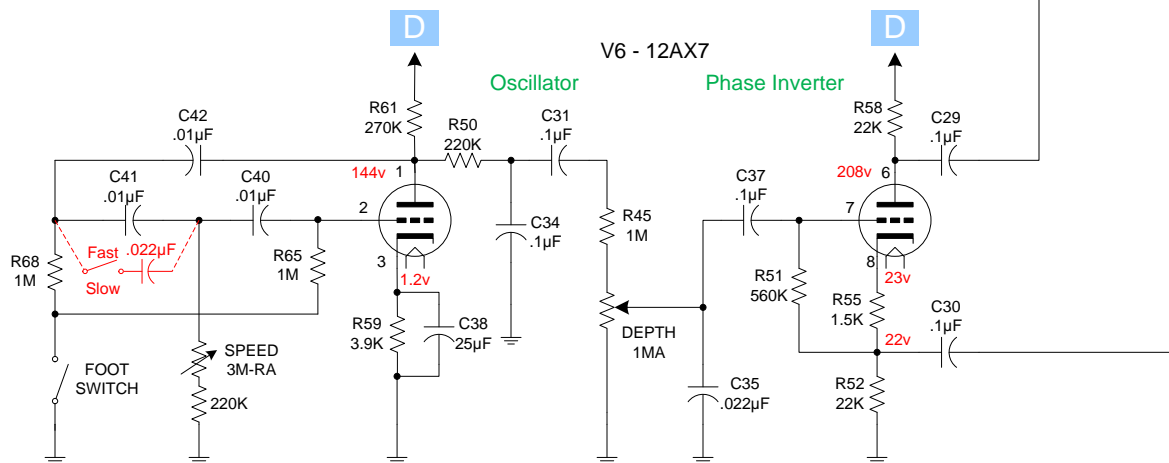

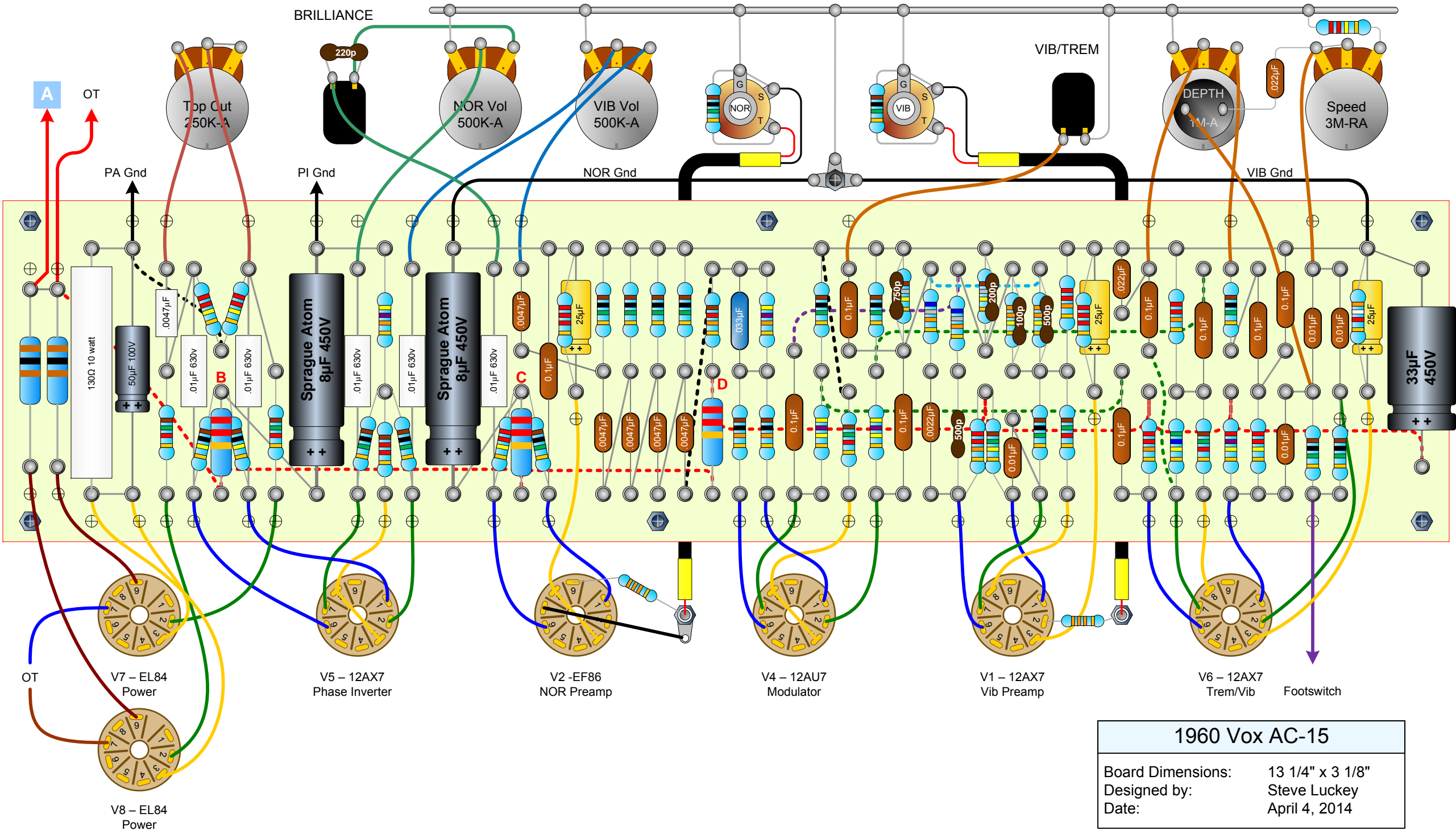

1960 Vox AC-15	
Board Dimensions:	13 1/4" x 3 1/8"
Designed by:	Steve Luckey
Date:	April 4, 2014

⊕ Turret --- drill size is 3/32"

⊕ Standoff – drill size to fit

⊕ Hole for wire pass thru – drill size to fit

----- Dashed lines are underboard jumpers

INSTRUCTIONS

Board size is 3 1/8" X 13 1/4". Print this drill guide FULL SIZE on 8 1/2" X 14" paper. Measure the board length of the printout to verify it is 13 1/4". Attach to blank board using double sided carpet tape. Use a center punch to put a mark at the cross hairs of each turret, standoff, and hole. Use a 3/32" drill bit to drill all holes. Then enlarge holes as needed for standoffs and wire pass thru.

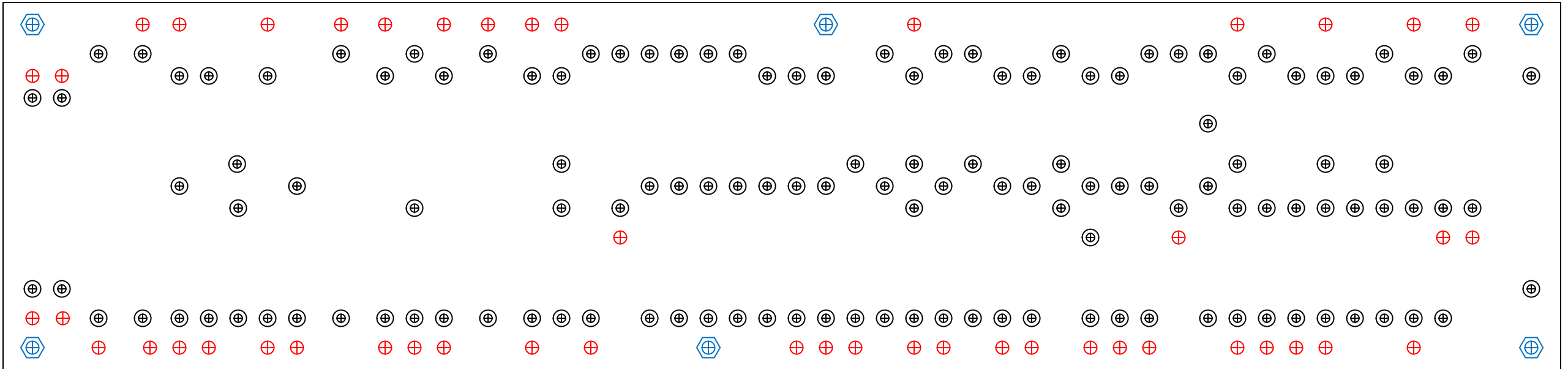

13.25

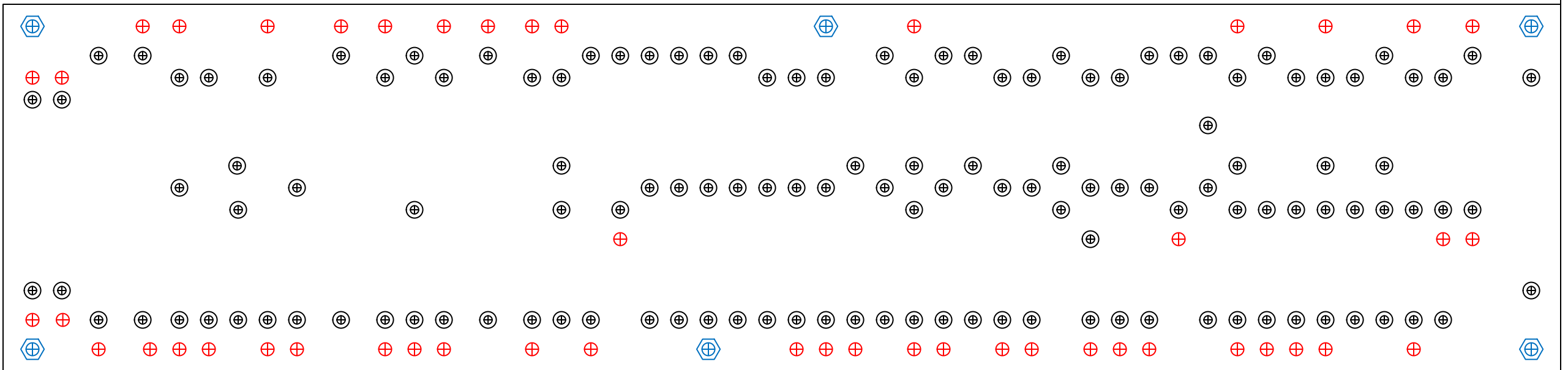

JUMPER GUIDE

<<< Use a highlighter to mark jumpers as they are installed. >>>

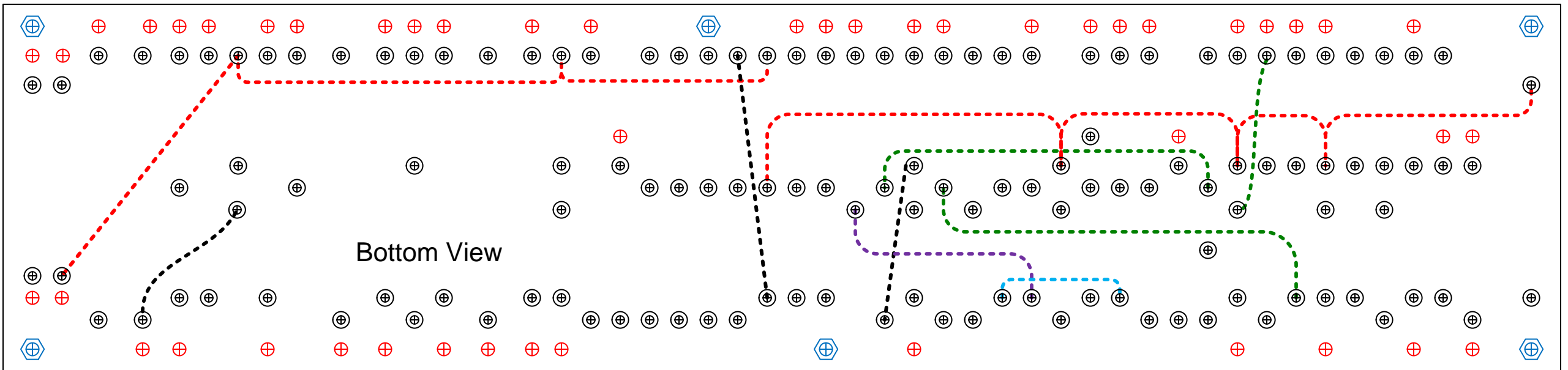
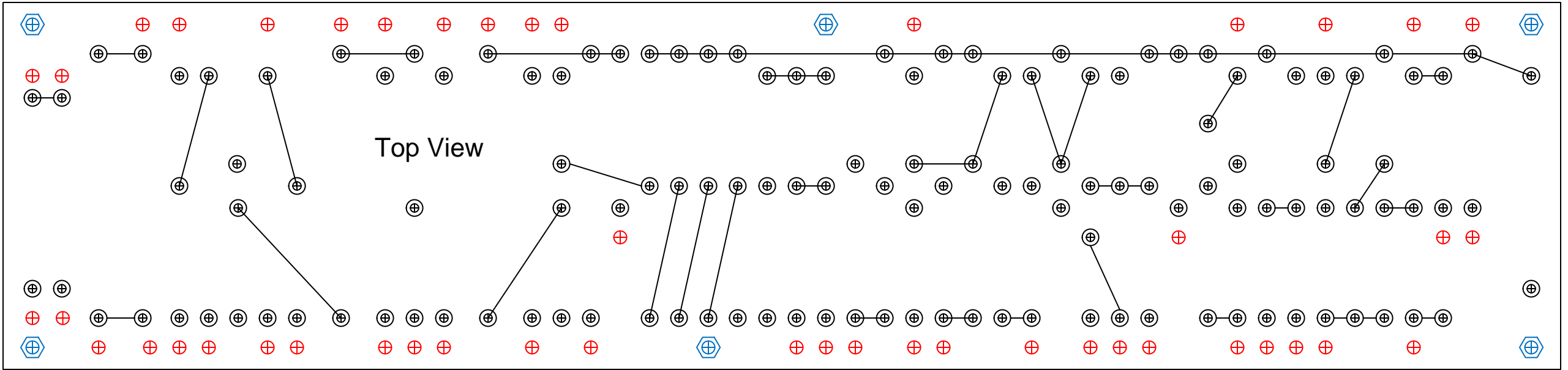

Ground Scheme

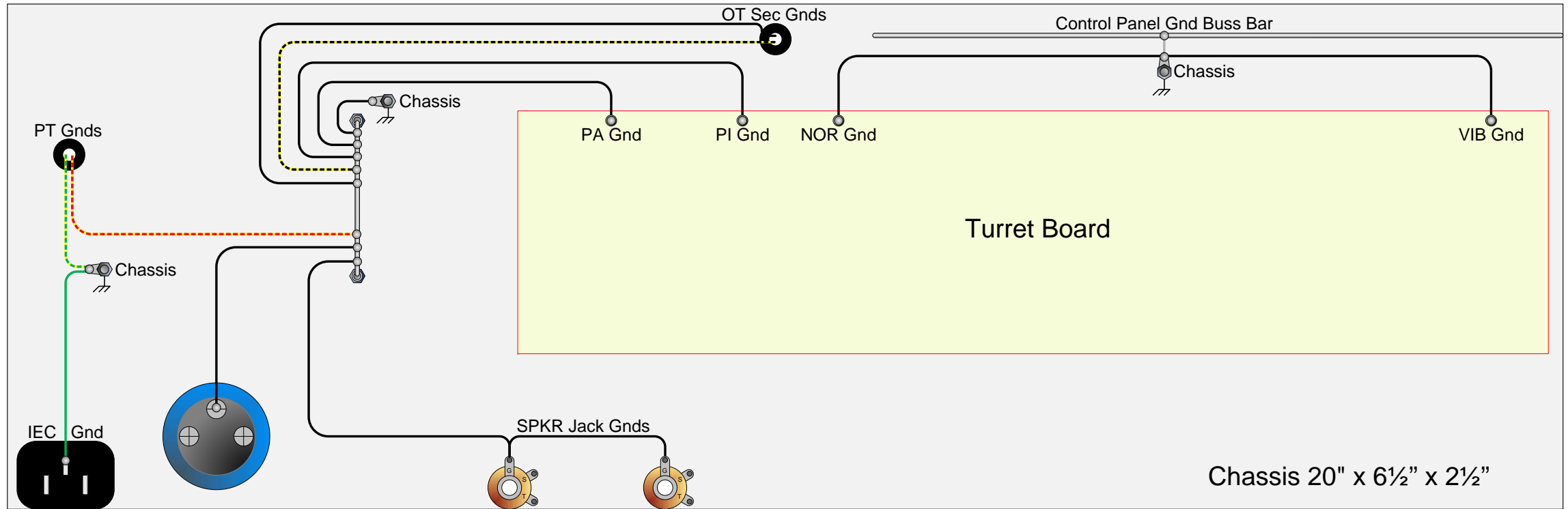

Cat. No.	VA	Primary		Secondary		Filament #1 (VAC)	Filament #2 (VAC)	Dim. Ref.
		VAC	Hz	(R.M.S.)	DC (ma.)			
270FX	138	115	60	275-0-275	150	5V @ 3A	6.3V @ 5A ct	X10

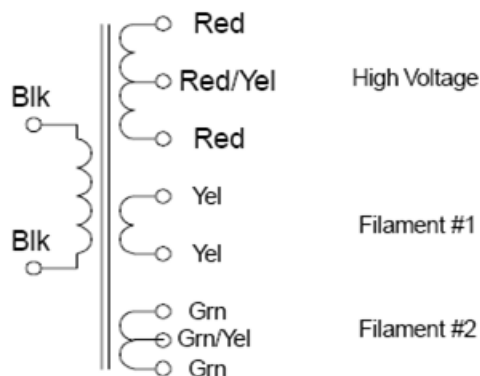

Cat. No.	Audio Watts	Primary Impedance	Secondary Impedance	Wt. Lbs.
1650F	25	7,600 ct	4-8-16	4

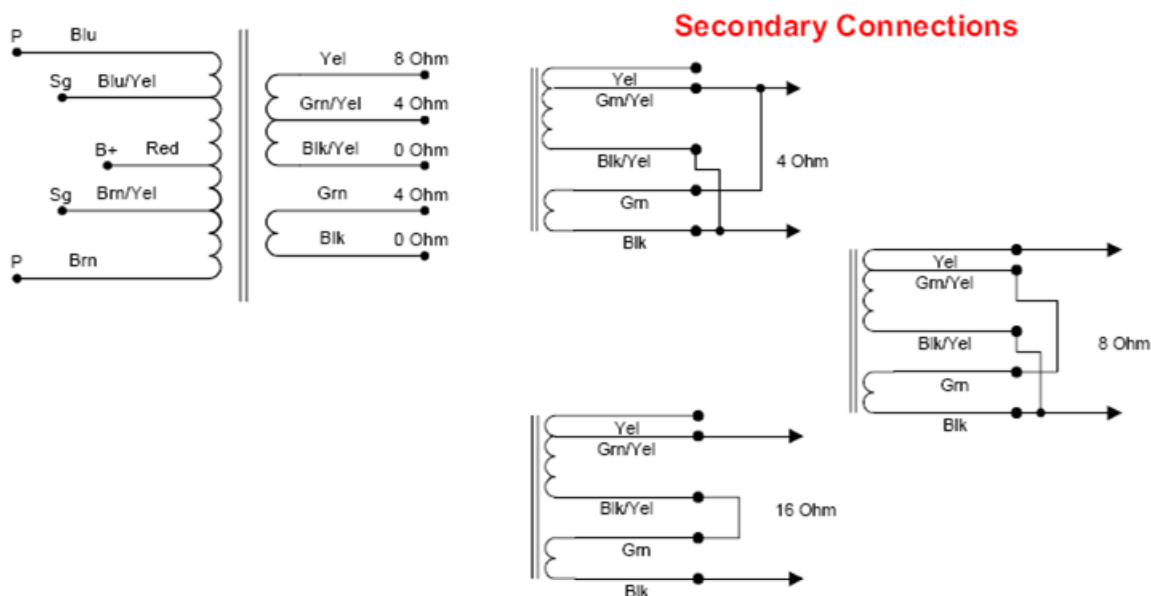

Part Number	Style	Inductance (Henrys)	D.C. Current (ma.)	Resistance (Ohms)	Maximum Operating (Volts D.C.)	Weight (lbs.)	Dimension Ref.
193T	Enclosed	0.05H	2000	0.7	300	2.5	X6
193U	Enclosed	0.2H	2000	1.7	300	6.0	X12
193V	Enclosed	0.15H	3000	1.0	300	9.0	X14
193B	Enclosed	12H	100	155	600	2.5	X6
193C	Enclosed	20H	100	181	600	3.25	X8

Vox AC-15 Small Parts List

63 RESISTORS			41 CAPACITORS			POTS		
Quantity	Value	Power	Quantity	Value	Voltage	Quantity	Value	Comment
2	100	3	3	25	25	2	500K-A	Volume
1	130	10	9	0.1		1	250K-A	Top Cut
1	1200		9	0.01		1	1M-A	Depth
5	1500		1	220p		1	3M-RA	Speed
2	2200		6	0.0047				
1	3900		1	50	25			
2	10000		1	16+16 can	450			
1	12000		2	8	450			
3	22000	3	1	33	450			
4	22000		1	0.0022				
2	47000		2	500p				
6	68000		1	750p				
2	100000		1	100p				
1	150000		1	200p				
2	180000		1	0.022				
4	220000		1	0.033				
1	270000							
3	330000							
2	470000							
2	560000							
16	1000000							
<i>unspecified resistors are 1/2 watt metal film</i>								