

Light Bulb Current Limiter

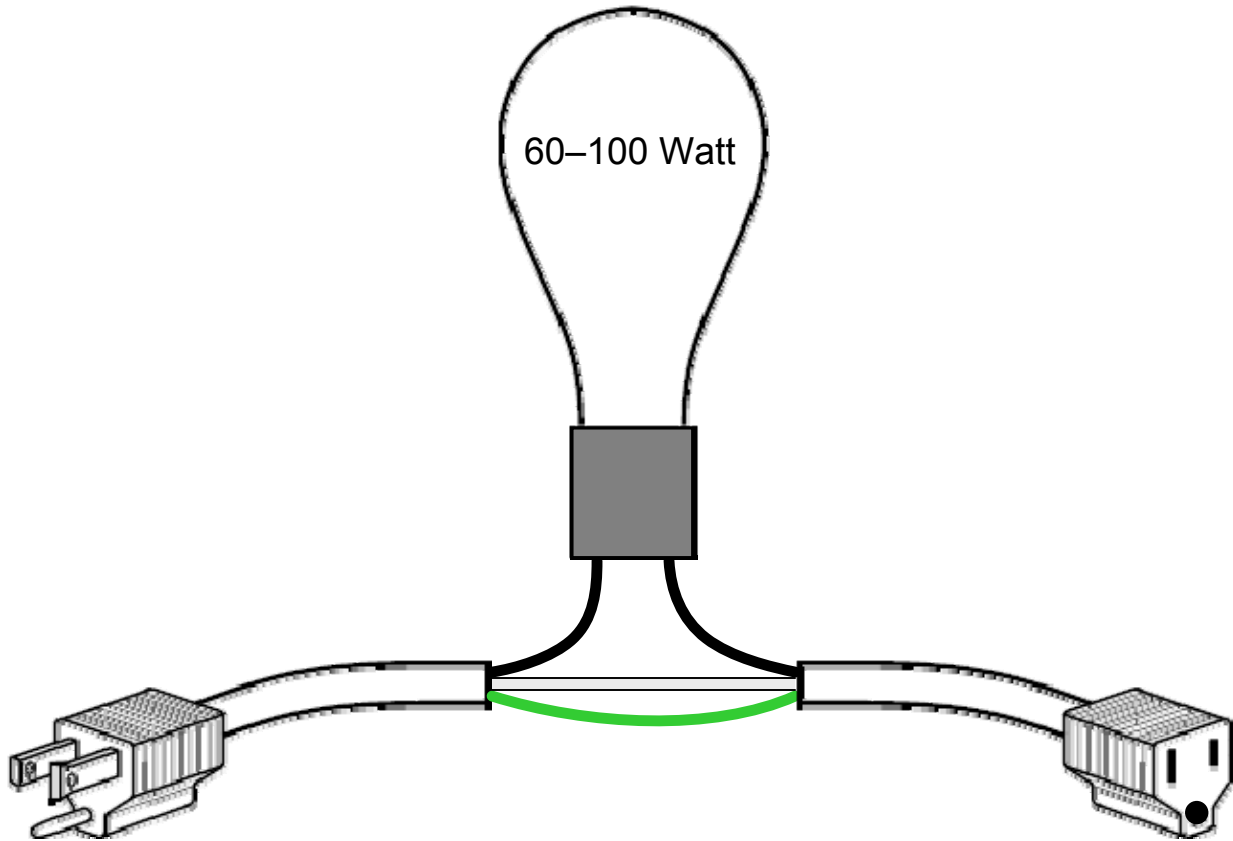

This workbench gadget allows you to connect a light bulb in SERIES with your amp. It will allow you to determine if your amp is drawing excessive current due to a shorted PT or filter caps, etc., without blowing fuses or smoking valuable components such as a PT. A dead short on the primary side of the PT will cause the bulb to glow at full brightness. Partial shorts or a short on the secondary side of the PT will show some increased level of brightness. A properly working amp will cause the bulb to glow fairly bright when first turned on, but will fade to a dimmer glow as the amp warms up.

Once you have confidence that there is no high current drain from your amp, you should remove this gadget. Voltage measurements will be very low and probably meaningless while your amp is plugged into this gadget.

Vintage AC adapter for old amps

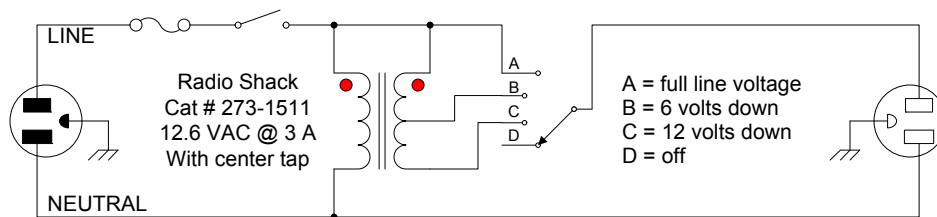
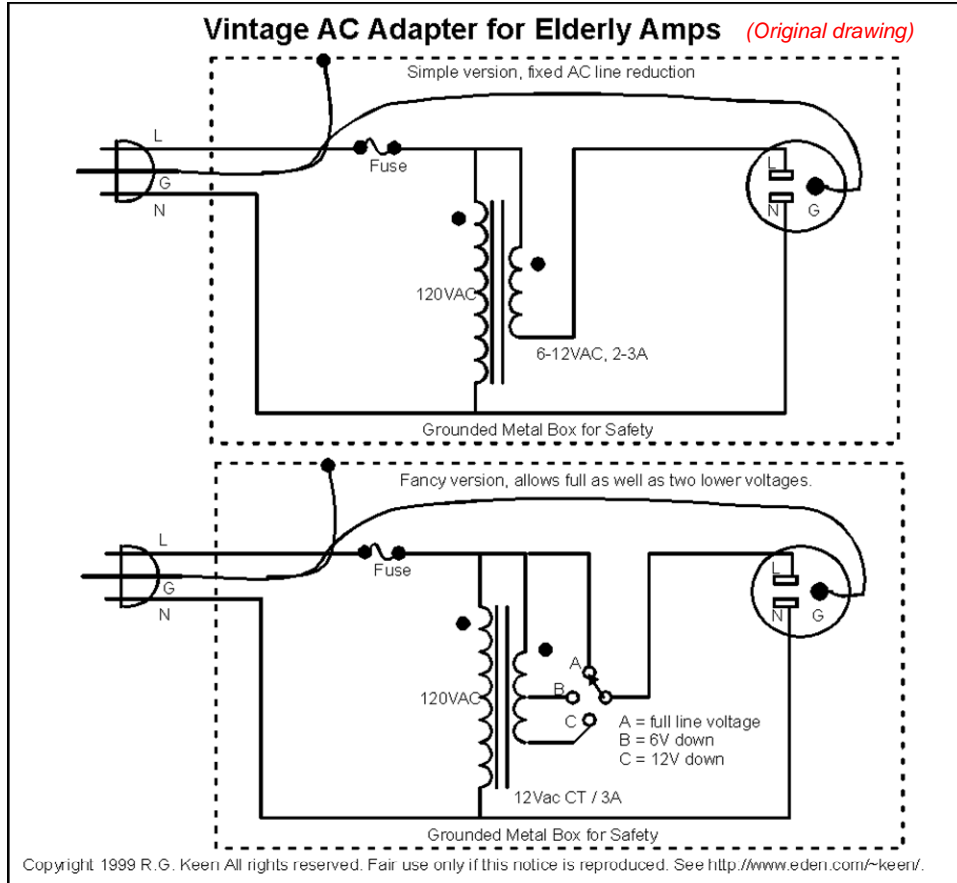

This gadget uses a “bucking” transformer to reduce AC line voltage. It’s useful for reducing today’s 120-125 VAC line voltage by approximately 6 or 12 volts which will also reduce your HT and filament voltages by an equal percentage. *(Tip. If you find that the output voltage actually increases, you have the transformer phased for a “boost” operation. Simply reverse the primary leads to correct this.)*

Power Switching Schemes

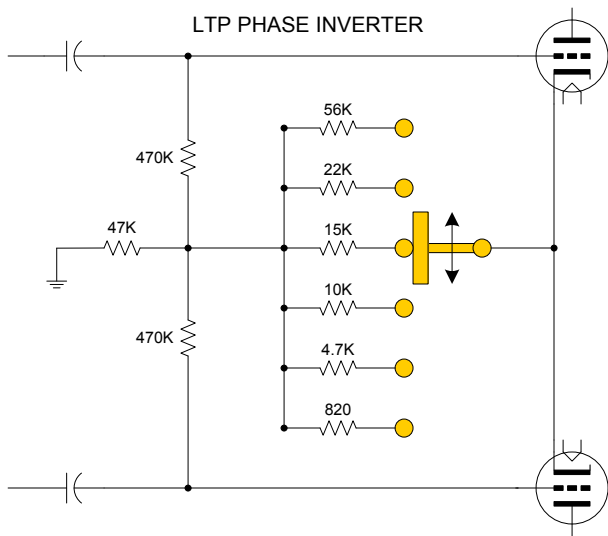
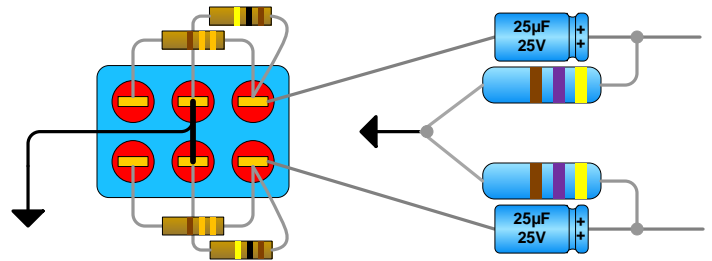

Marshall 18 Watt Power Dampening Switch
(can be adapted to other LTP phase inverters)

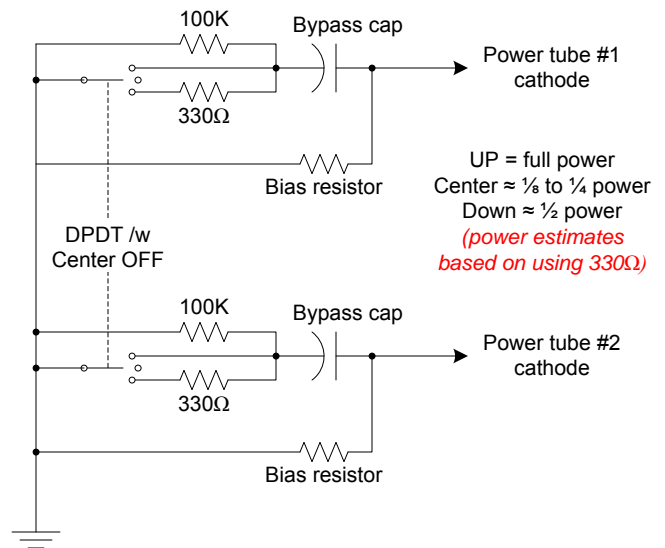

Da Geezer's Bypass Cap attenuator
(Bias resistor value will be 2X the value of a single bias resistor)

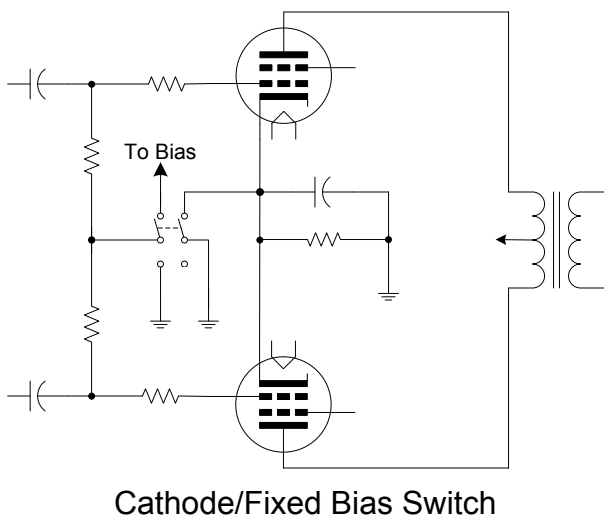

Cathode/Fixed Bias Switch

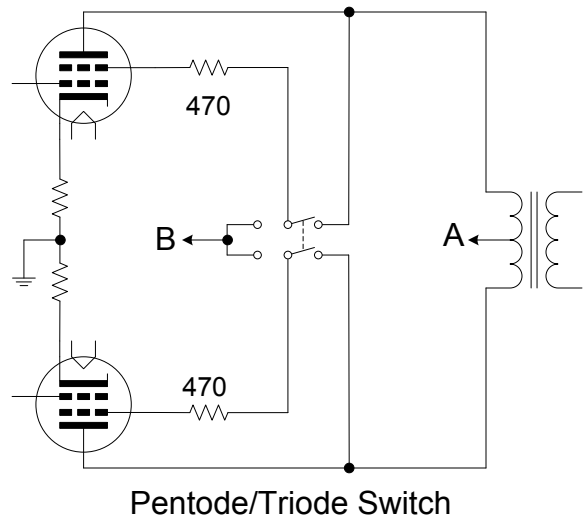

Pentode/Triode Switch

True Bypass Switch Box

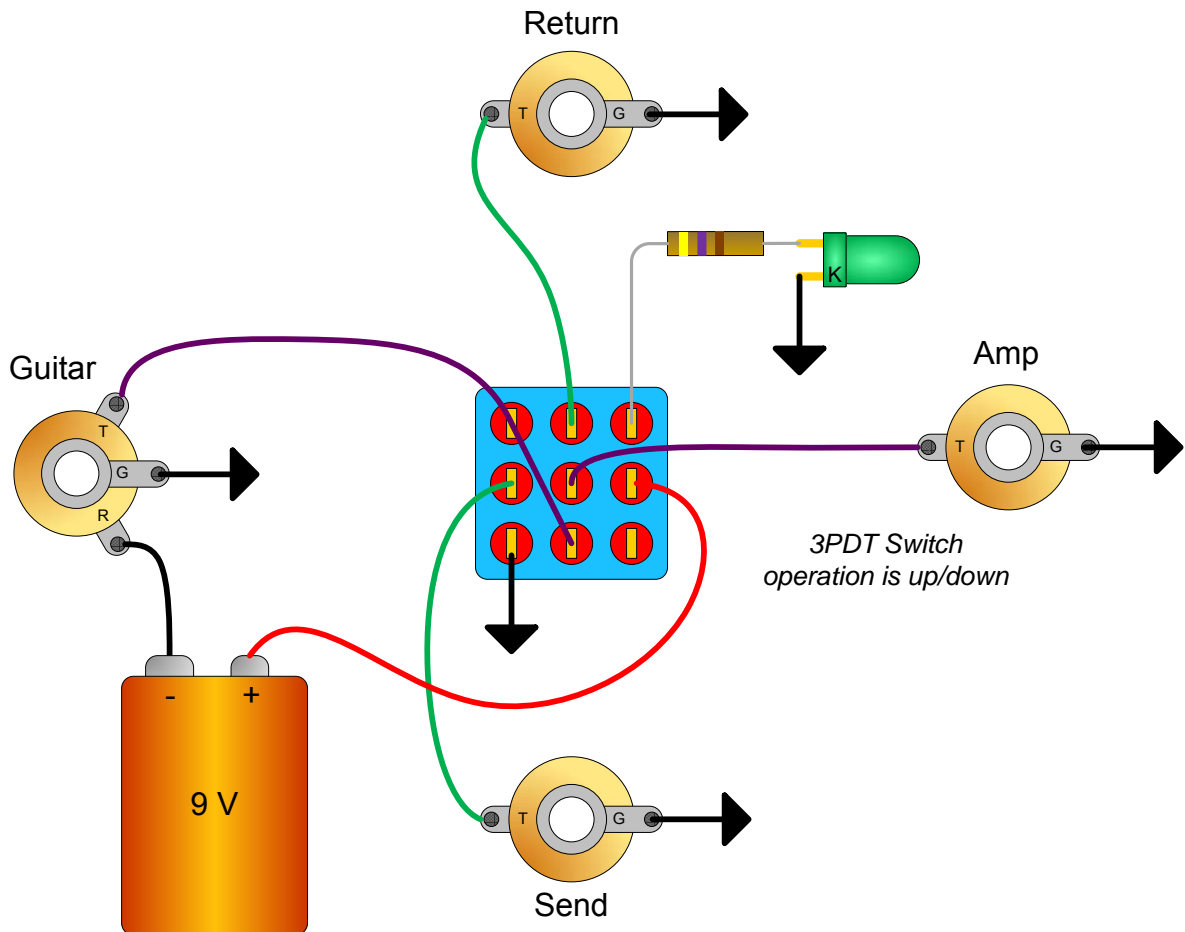
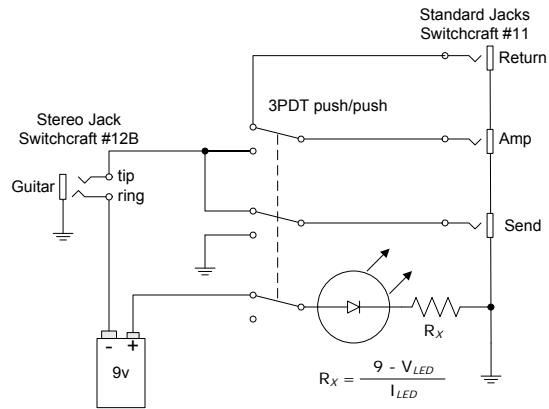

Bias Circuits

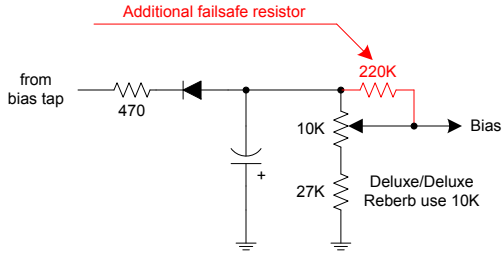

Typical Fender AB763

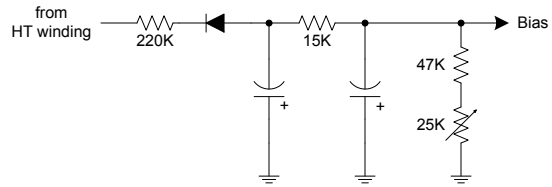

Typical Marshall

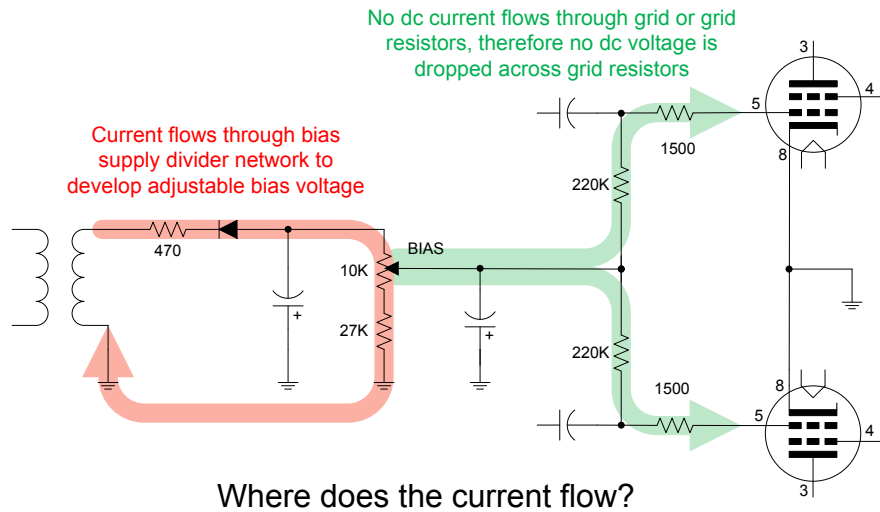

Where does the current flow?

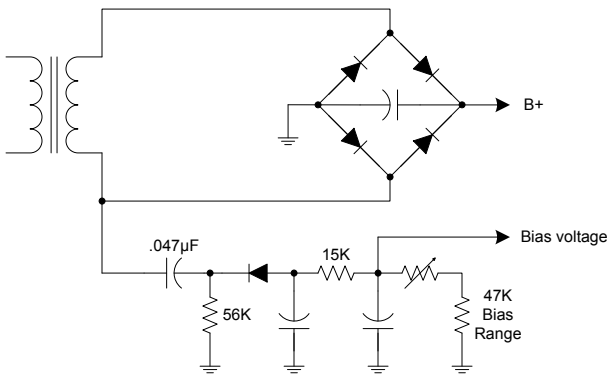

Bias circuit and full wave bridge
(from Marshall JCM900 and some old Ampegs)

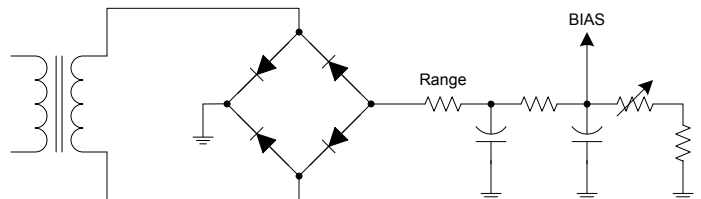

Separate bias winding and full wave bridge
(nice when you have a separate bias winding)

Fixed/Cathode Bias Switching

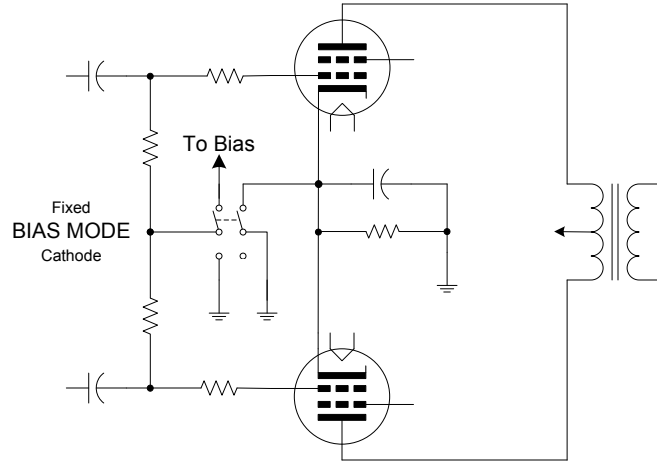

Figure 1. Use this DPDT switch with any bias supply.

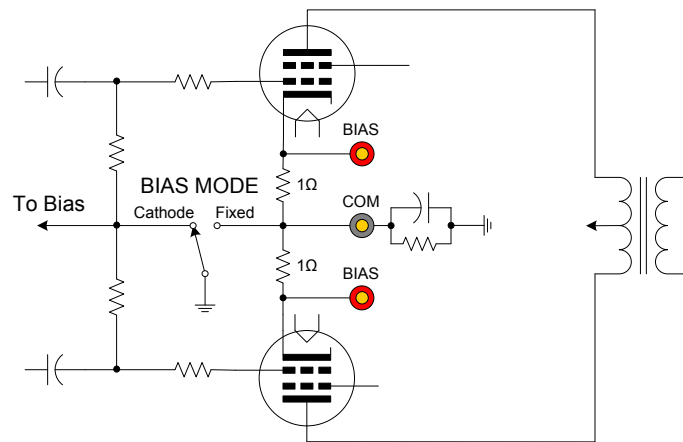

Figure 2. Use this SPDT switch with a bias supply that gets it's AC supply from one end of the PT HT winding *****AND***** uses a high value resistor between the PT and the bias rectifier/filter circuit. *(See Fender Princeton Reverb for example.)*

Understanding Hi/Lo Input Jack Switching

Hi/Lo Input jack switching is often misunderstood. The operation is usually straightforward, but the actual circuit drawing is often confusing, especially to the casual observer. Hopefully the following illustrations will demystify the circuit operation.

These first two circuits represent the typical Hi/Lo jacks found in most Fender and Marshall amps. Many other amp manufacturers use this circuit as well.

Using the Lo Input

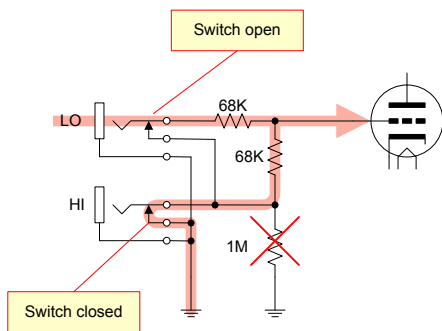

The LO jack delivers the signal to a 2:1 voltage divider made up of the two 68K resistors. The 1meg is shorted out by the switch contacts on the HI jack. The signal taps off the junction of the two 68Ks. Half the signal is dropped across each 68K, therefore only 50% of the signal is applied to the tube.

Using the Hi Input

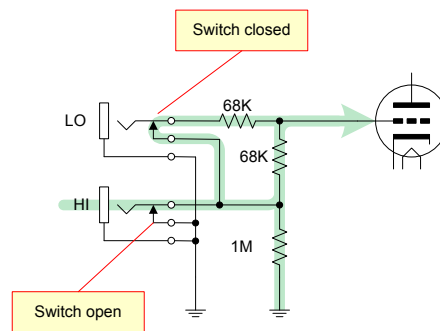

The HI jack delivers **ALL** the signal to the tube. The signal enters the HI jack and first sees a 1 Meg resistor to ground. Since the LO jack switch is closed, the two 68Ks are parallel for an effective resistance of 34K and the signal travels through the paralleled 68Ks to the tube. There is no voltage divider so 100% of the signal arrives at the tube.

The following circuits represent special case switching. The first shows the Marshall 18 Watt parallel tube switching circuit and the other shows a Marshall JCM-800 high gain cascade switching circuit.

Marshall 18 Watt Normal Channel Inputs

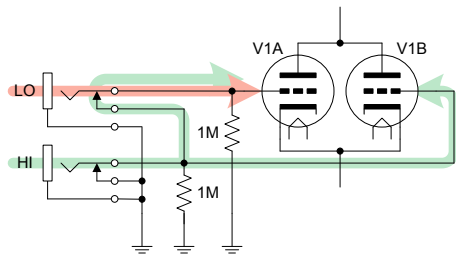

The LO jack delivers the signal to V1A only. The HI jack delivers the signal directly to V1B and also to V1A through the closed switch of the LO jack. The parallel tubes give a fatter sound with a slight gain increase.

Marshall JCM-800 2204 Channel Inputs

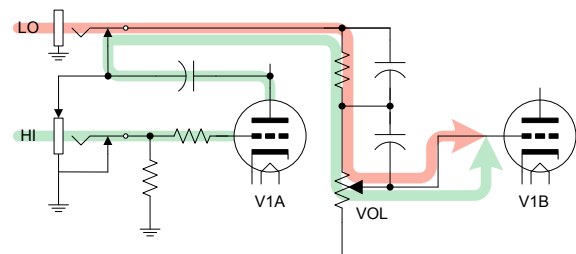

The LO jack delivers the signal directly to V1B for a single gain stage. The HI jack delivers the signal to V1A and then to V1B through the closed switch of the LO jack. The cascaded tubes give a high gain sound.

Vox AC-30 Hi/Lo Input Jack Switching

There are two variations of the input switching jacks for this amp. Type A is the classic circuit that has been used in many Fender and Marshall amps. Type B uses a slightly different circuit to accomplish the same functionality. The Hi input operation is slightly different for the two type circuits. However, the difference is so slight that it can be practically ignored. You would need precision lab equipment to even measure the slightly different signal levels applied to the tube grid. When comparing the Lo input operation, it can be seen that the two type circuits become identical, although achieved through a slightly different approach.

Hopefully, the summary below will explain the functionality of both types and also point out the slight differences.

Type A Using the HI input

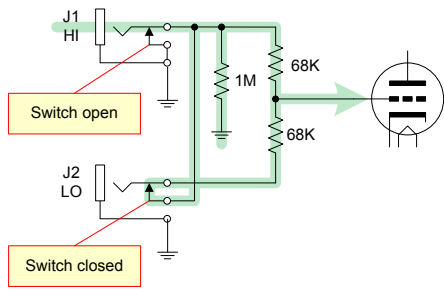

The HI jack delivers ALL the signal to the tube. The signal enters the HI jack and first sees a 1 Meg resistor to ground. Since the LO jack switch is closed, the two 68Ks are parallel for an effective resistance of 34K and the signal travels through the paralleled 68Ks to the tube. There is no voltage divider so 100% of the signal is applied to the tube.

Type B Using the HI input

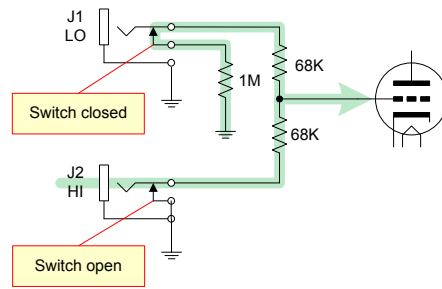

The HI jack delivers almost ALL the signal to the tube. The signal enters the HI jack and is applied to a voltage divider consisting of both 68Ks and a 1M through the closed switch on J1. 6% of the signal is dropped (lost) across the first 68K. The other 94% signal that is dropped across the second 68K and 1M is applied to the tube.

Type A Using the Lo input

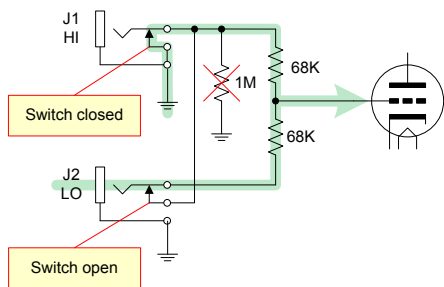

The LO jack delivers the signal to a 2:1 voltage divider made up of the two 68K resistors. The 1meg is shorted out by the switch contacts on the HI jack. The signal taps off the junction of the two 68Ks. Half the signal is dropped across each 68K, therefore only 50% (-6db) of the signal is applied to the tube.

Type B Using the Lo input

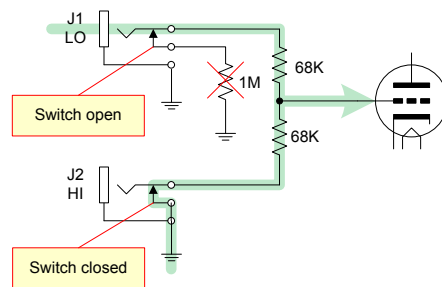

The LO jack delivers the signal to a 2:1 voltage divider made up of the two 68K resistors. The 1meg is removed from the circuit by the switch contacts on the HI jack. The signal taps off the junction of the two 68Ks. Half the signal is dropped across each 68K, therefore only 50% (-6db) of the signal is applied to the tube.

SS/Tube Rectifier Switching

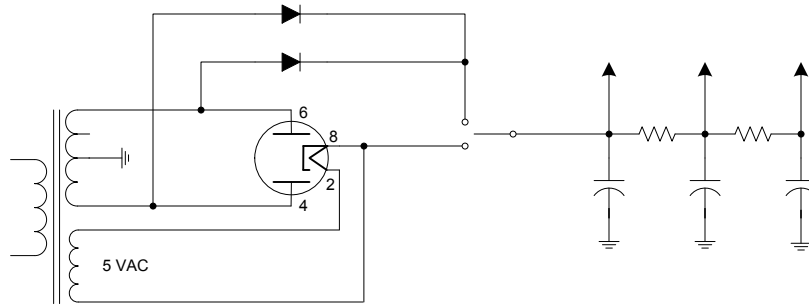

Using a SPDT Center Off switch allows for SS – STBY – TUBE function.

Hybrid SS/Tube Bridge Full Wave Rectifier

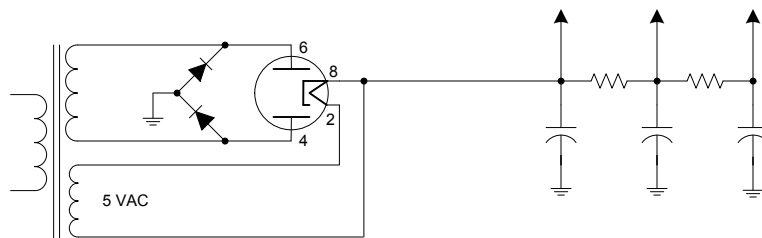

This full wave bridge circuit retains the characteristics of a tube rectifier.
Note there is no center tap on the HT winding.

Fender 6G4A Tremolo

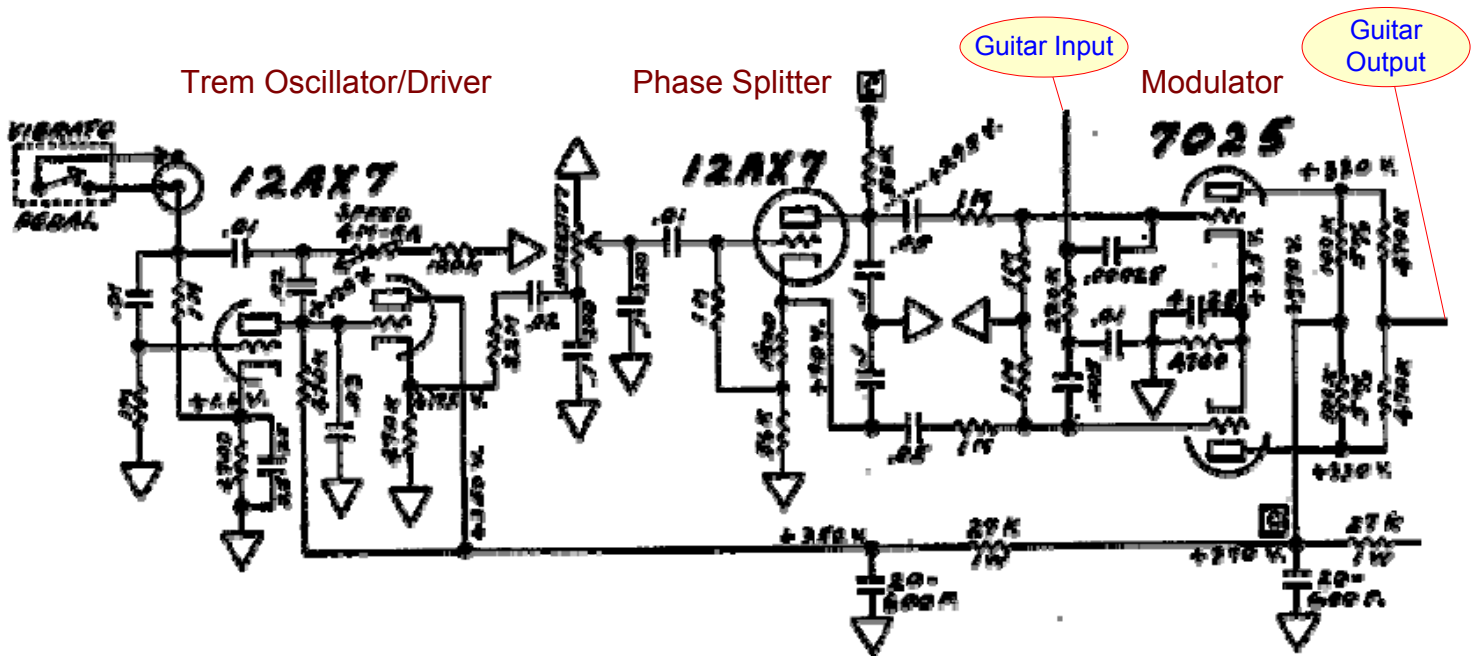

The Oscillator is a standard Phase Shift Oscillator that operates at a low frequency range of approximately 2-20 Hz. The oscillator output is coupled through a cathode follower driver and then applied to the input of a phase splitter through the Intensity control. The phase splitter produces two identical outputs that are 180° out of phase with respect to each other. Each output is coupled to the grid of a modulator tube and will control the gain of that tube by modulating the bias at the slow oscillator frequency.

The input guitar signal is split and also applied to the grids of the modulator tubes. However, the guitar signal passes through a high pass filter to get to the top tube and passes through a low pass filter to get to the bottom tube. So, the top tube amplifies only the high frequency components of the guitar signal and the gain is varied/modulated by the Tremolo oscillator signal. Likewise, the bottom tube amplifies only the low frequency components of the guitar signal and the gain is varied/modulated by the Tremolo oscillator signal that is 180° out of phase with the top Tremolo signal.

The modulated high frequency guitar signal is recombined with the low frequency guitar signal in the two 470KΩ mixing resistors. The out of phase Tremolo signals are also recombined in these mixing resistors, but since they are equal amplitude and 180° out of phase, the Tremolo signals cancel each other, leaving only the guitar signal. Since the Tremolo signals cancel each other, you will not hear the Tremolo signal 'breathing' when no guitar signal is applied.

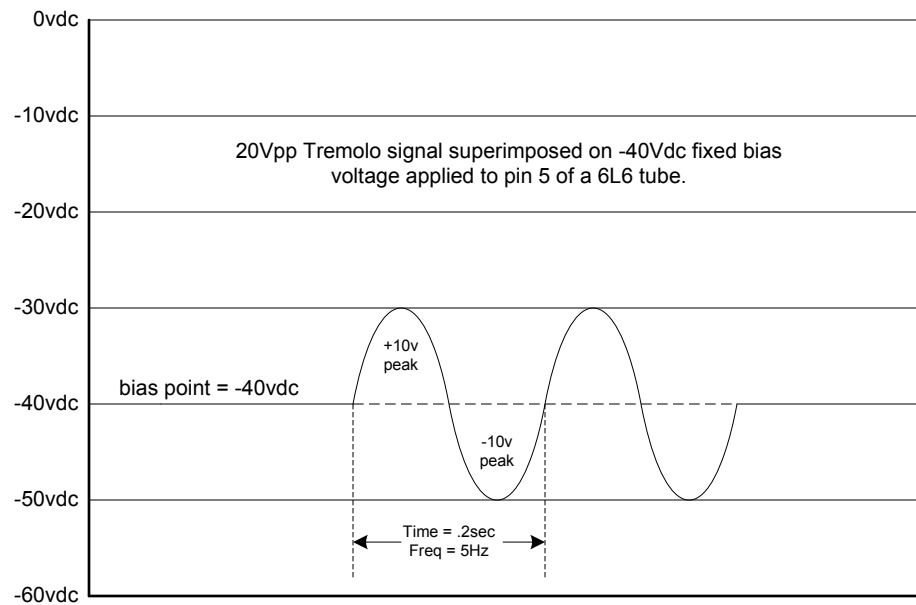

This graph shows that a 20Vpp Tremolo signal superimposed on -40Vdc fixed bias voltage will cause the resultant bias voltage to vary between -30vdc and -50vdc. You could simulate the tremolo effect simply by rhythmically adjusting the bias pot between -30 and -40vdc. Changing the bias will affect the gain of the 6L6 thus varying the loudness of the instrument signal.

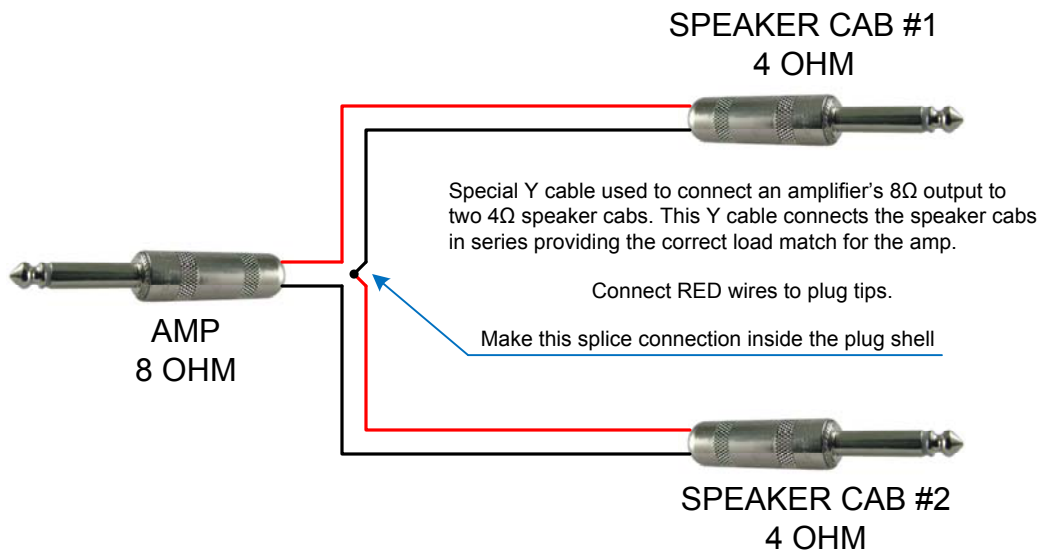

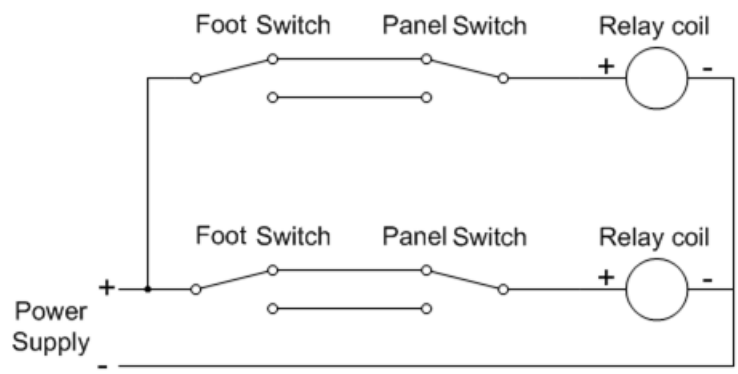

Dual 3-Way footswitch for relays

Typical Fender Mains Wiring

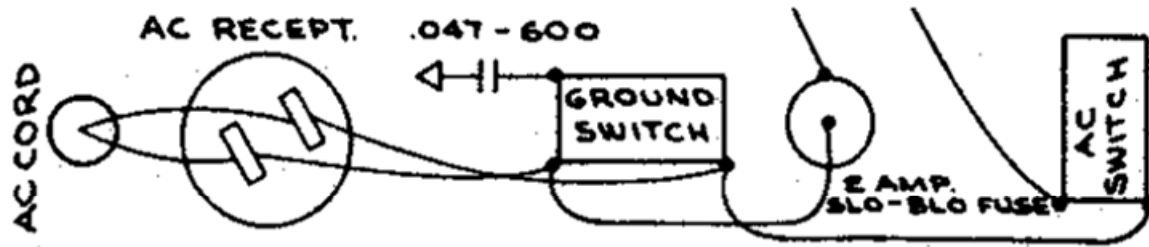

Improved Fender Mains Wiring

