

**Excelsior - 50WR
Pre-Amp**

| DRAWN BY | SHEET | DATE | SCALE |
|-----------------------------------|--------|------------|-------|
| KEVIN E. WATERS | 1 OF 4 | 01/11/2020 | |
| EXCELSIOR AMERICANA (SANO) | | | |
| TREMOLO & REVERB | | | |
| SPEAKERS: 2 - 12" (main) | | | |
| 1 - 6" (reverb) | | | |
| EXCELSIOR | | | |

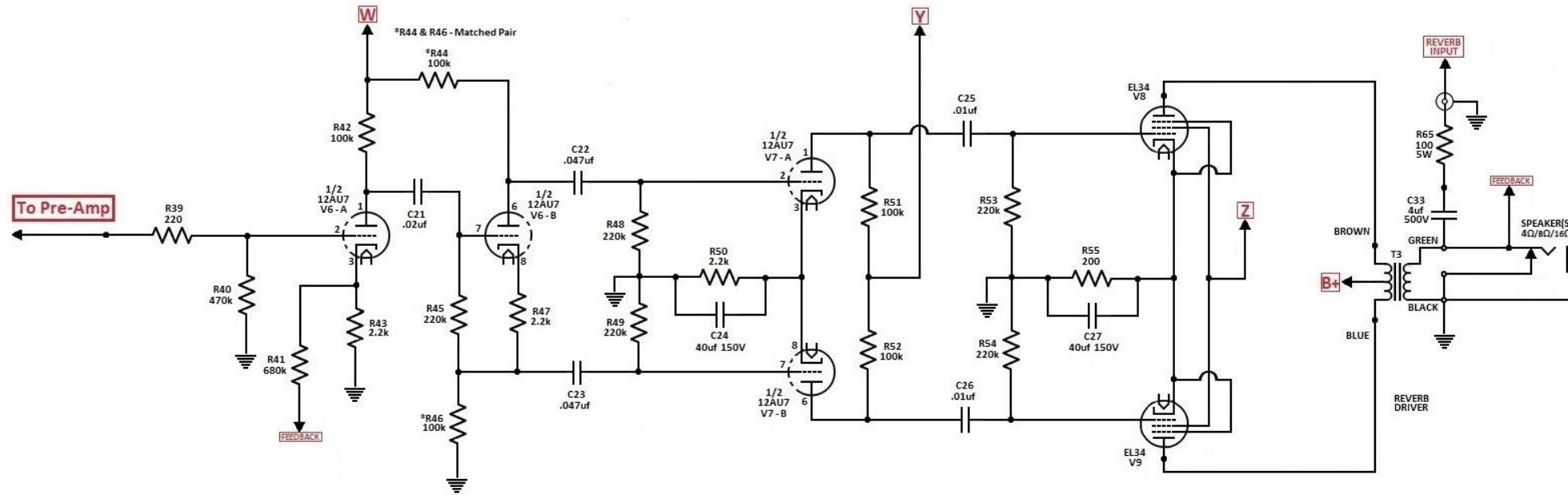

**Excelsior - 50WR
Power-Amp**

| DRAWN BY | SHEET | DATE | SCALE |
|---|--------|------------|-------|
| KEVIN E. WATERS | 2 OF 4 | 01/11/2020 | |
| EXCELSIOR AMERICANA (SANO) TREMOLO & REVERB SPEAKERS: 2 - 12" (main) 1 - 6" (reverb) | | | |
| EXCELSIOR | | | |

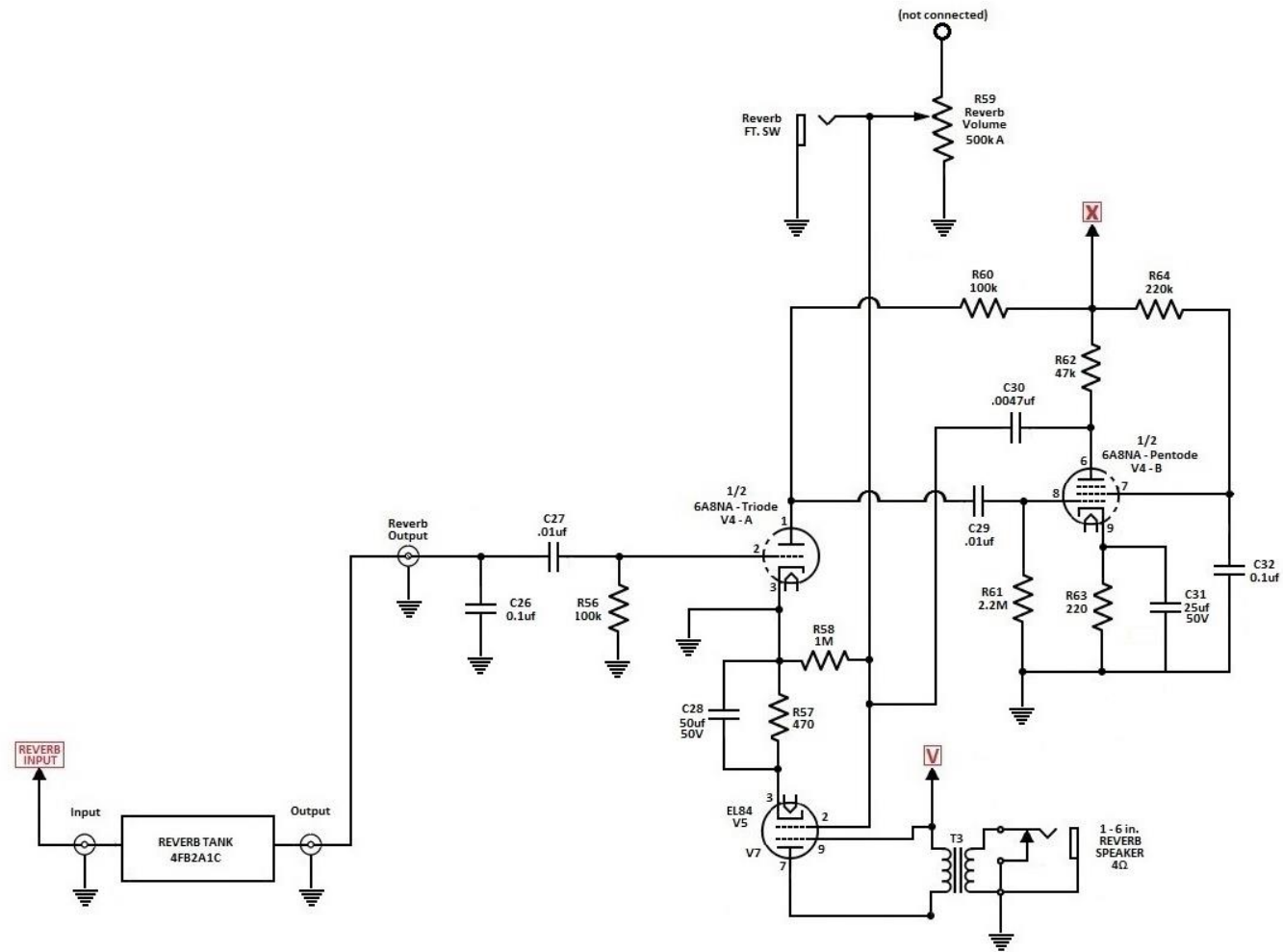

**Excelsior - 50WR
Reverb**

| DRAWN BY | SHEET | DATE | SCALE |
|--|--------|------------|-------|
| KEVIN E. WATERS | 3 OF 4 | 01/11/2020 | |
| EXCELSIOR AMERICANA (SANO) TREMOLLO & REVERB SPEAKERS: 2 - 12" (main) 1 - 6" (reverb) | | | |
| EXCELSIOR | | | |

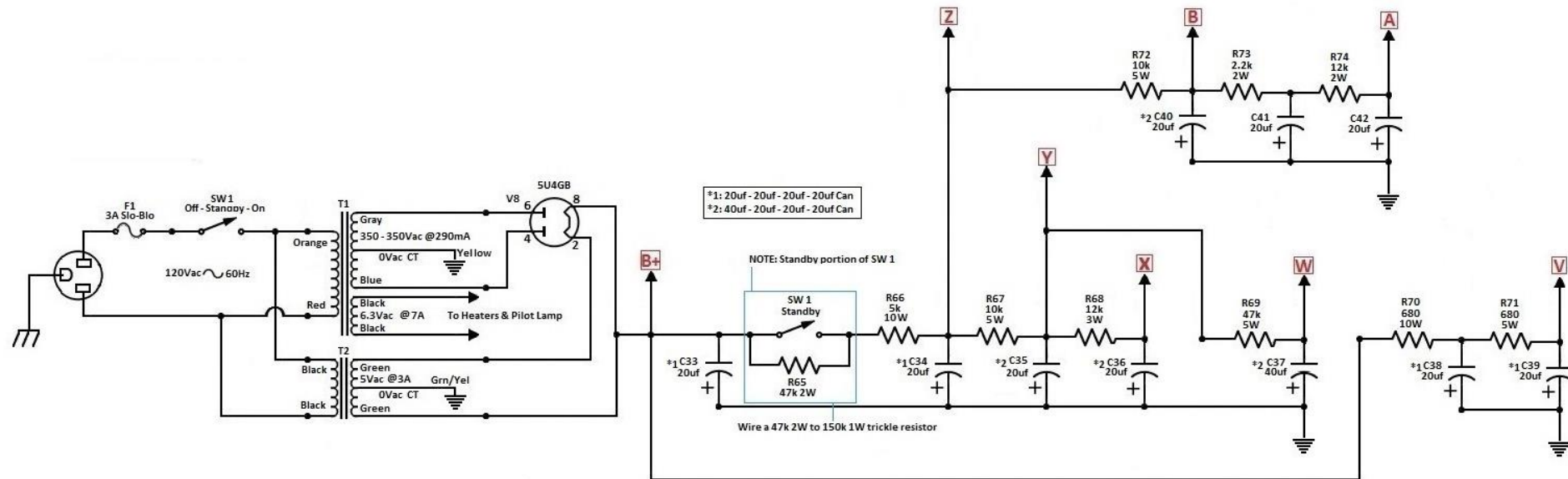

**Excelsior - 50WR
Power Supply**

| DRAWN BY | SHEET | DATE | SCALE |
|---|--------|------------|-------|
| KEVIN E. WATERS | 4 OF 4 | 01/11/2020 | |
| EXCELSIOR AMERICANA (SANO) TREMOLO & REVERB SPEAKERS: 2 - 12" (main) 1 - 6" (reverb) | | | |
| EXCELSIOR | | | |