

11 1/2"

3 1/8"

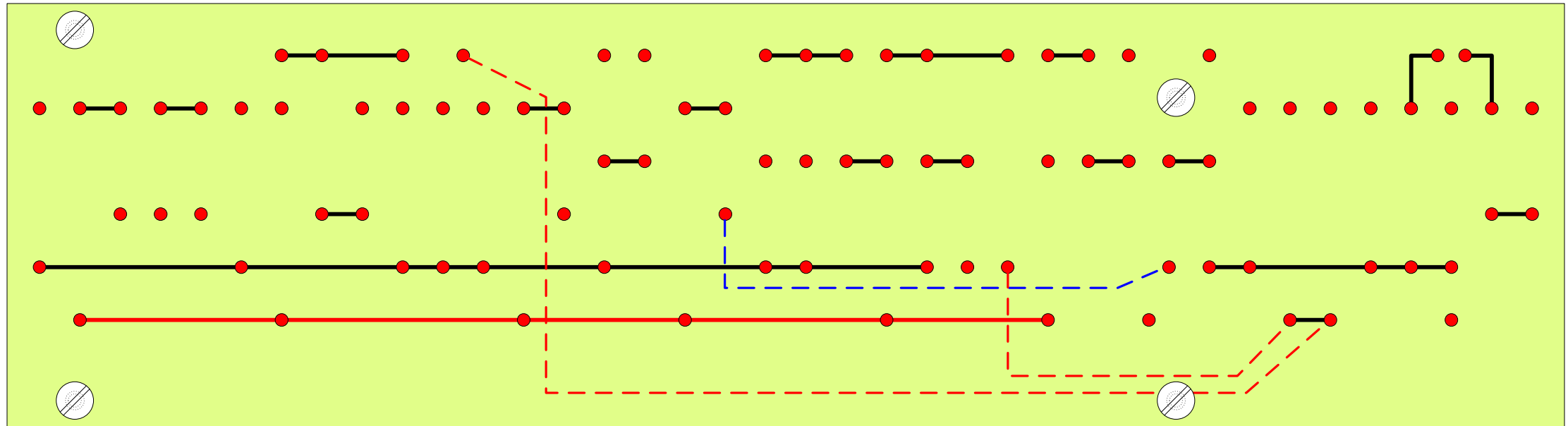

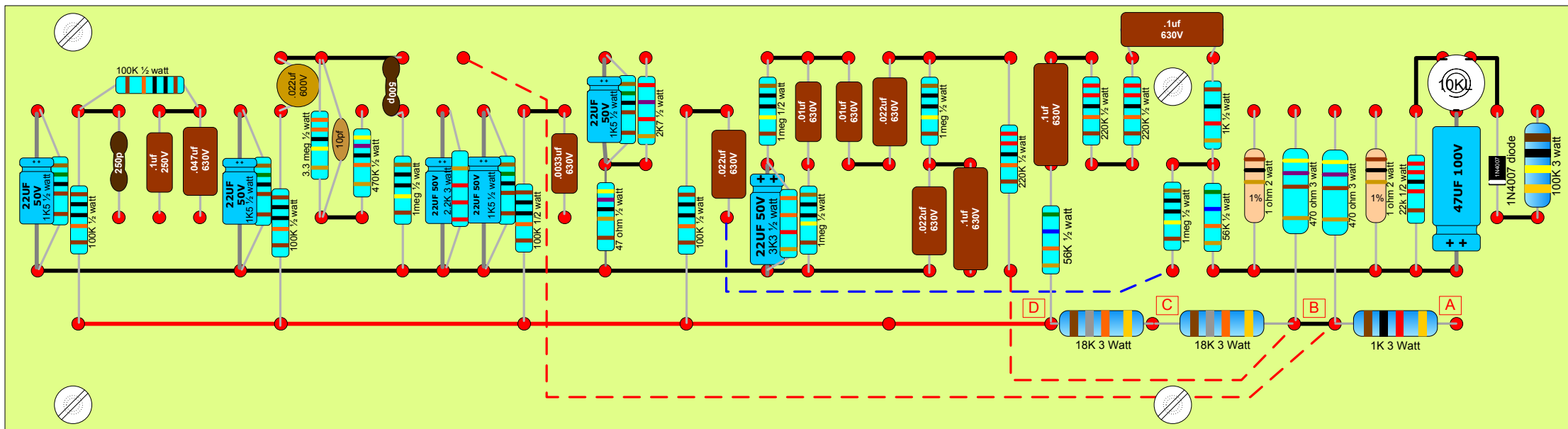

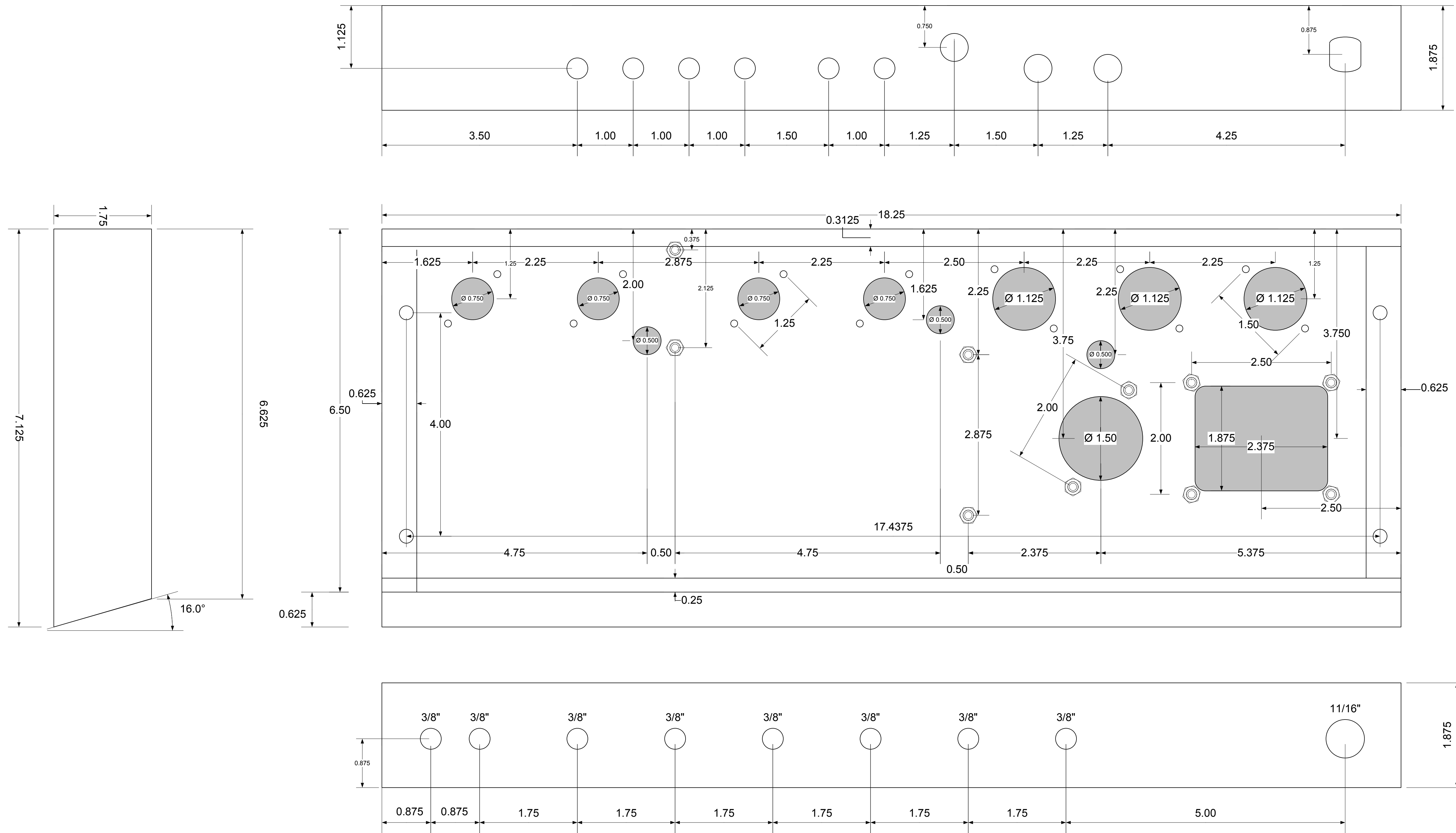

C1	FENDER PRINCETON REVERB CHASSIS			
	MOJO MUSICAL SUPPLY			
DATE	FSCM NO	DWG NO	REV	
SCALE	1:1	SHEET	4 OF 8	

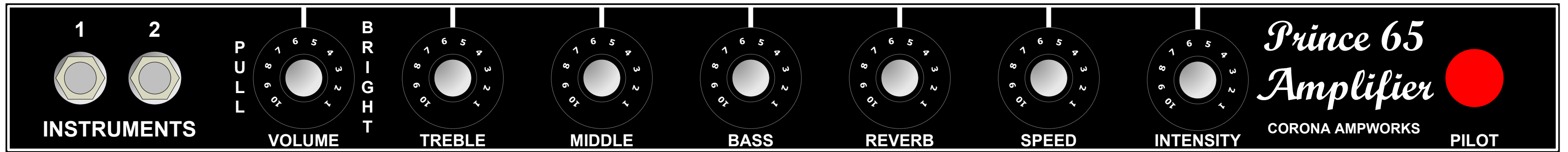

Front plate

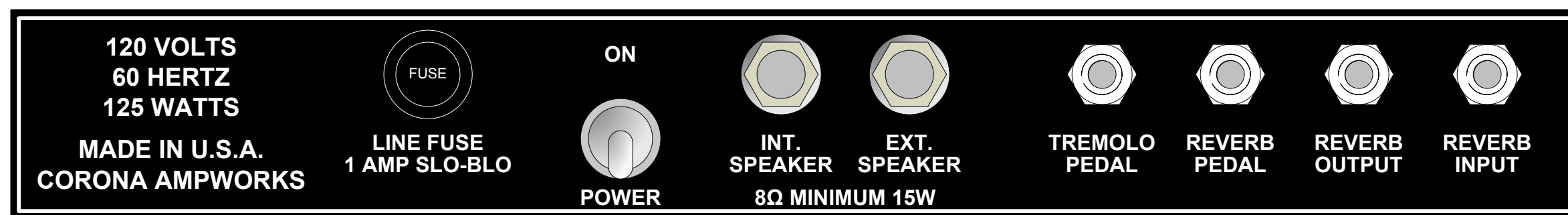
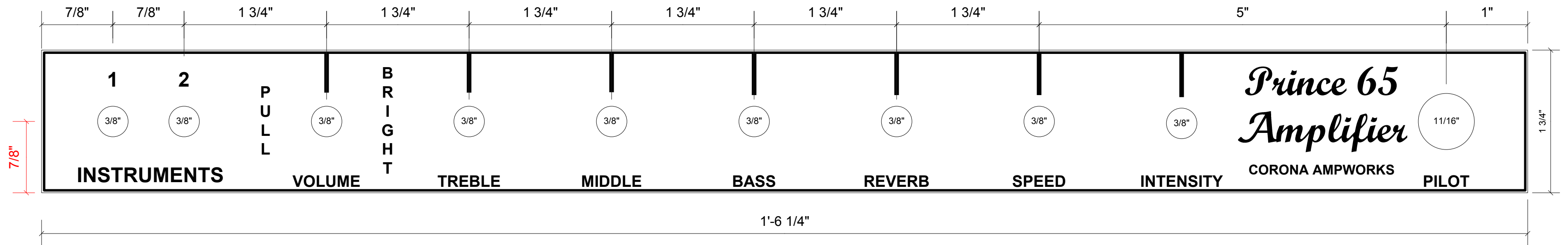

Back plate

