

VVR3 Variable Voltage Regulator



Fixed Bias VVR3



Cathode Bias VVR

Methods to control the power output in a musical instrument amplifier have been around for a long time. The first patent that I have found for regulating power was filed in October of 1979. Patent number 4,286,492 was granted on 9/1/1981. It was invented by Guy P. Claret and he called it his "Control for Electronic Amplifiers"

"A circuit which allows for simultaneous control of the bias voltages applied to the screen grids and control grids of output tubes while maintaining the ratio of said voltages there by providing a method for selectively varying a single plate characteristic (Power Output) of a tetrode / pentode vacuum tube"

Over the next couple of decades other people came out with different ways to vary the voltages in a guitar amp to change the power level of the amplifier. Some boutique amp manufacturers have started using variable power as a standard circuit in their own line of amps and there are a number of manufacturers using the VVR under different names as their power attenuator of choice. Our VVRs have been installed in thousands of amps over the last 5 years and is a proven and solid design when installed properly. The VVR is a simple circuit that when installed in a musical instrument amplifier will make the B+ voltage and bias voltage variable from 100% power to a minimum power level which is selectable by changing resistor values.

While it is a simple circuit it is not a simple mod to install. It should only be installed by a qualified amplifier technician. Use this circuit at your own risk! I do not warranty it, either expressed or implied, for any use in any amplifier. By installing this board in your amplifier, you are agreeing that you will assume all responsibility for its safe operation. If you don't agree with these terms then send the board back in re-sellable condition for a full refund.

You can regulate voltages to just your power tubes or the whole amp or any other portion in between. You need to talk this over with your tech as there may need to be additional parts that need to be installed in addition to the VVR board. It would be impossible for me to offer design assistance to install this in any amplifier that has ever been made. In the following pages, I will try and give you as much info as I have available.

The VVR board is designed to be used on amps of 50 watts and lower. I am sure that by adding an additional (paralleled) mosfet and a few more components it could be made to work with higher power amps. Between 30 – 50 watts heat becomes an issue and you need to add some kind of heat sink for the mosfet in addition to just the amp chassis. Aluminum dissipates heat better than steel. I have successfully used the VVR in amps from 5 to 30 watts without needing to add additional heat sinking other than the chassis itself. With the mosfet bolted to the chassis it should just get warm and not hot to the touch. You should test for proper heat sinking after installation at different power levels and after different periods of playing time.

You can regulate voltages to just your power tubes or the whole amp or any other portion in between. You need to talk this over with your tech as there may need to be additional parts that need to be installed in addition to the VVR board. It would be impossible for me to offer design assistance to install this in any amplifier that has ever been made. In the following pages, I will try and give you as much info as I have available.

Installation Instructions

Cathode Bias vs Fixed Bias.

There are two different Bias circuits used in amps. The cathode bias method uses a resistor in series with the cathode of the power tube(s). As current flows through the tube it develops a voltage across

the cathode resistor making the cathode positive in respect to the grid of the tube. Looking at it a different way, it also makes the grid negative in respect to the cathode providing a negative bias on the grid. The bias sets the operating point of the tube on a linear portion of its published curve charts provided by the manufacturer in their data sheets. Cathode bias is sometimes called self bias. In a cathode biased amp, as you turn down the B+ voltage using a VVR it causes the tube to draw less current. This in turn causes the voltage drop across the cathode resistor to change, changing the bias point of the tube automatically.

With fixed bias, you have a “Bias supply” that is just like a HV supply in your amp only it creates a negative DC voltage that is applied to the grids of the power tubes. This bias voltage is usually adjustable so that you can dial in the best bias voltage for the tubes you are using. Unlike the Cathode bias the fixed bias doesn't change when you change the B+ voltage in your amp. This makes it a little more complicated to install a variable voltage regulator because you now have to turn down the bias voltage in proportion to the amount you turn down the B+ voltage. The VVR3 has additional circuitry on the board to do just that.

We will talk about installing the VVR in a cathode bias amp first. The installation is the same in both types of amps as far as regulating the whole amp or just the power section. There are additional components that may need to be installed to make each one work.

Pictorial Diagram of VVR Installed regulating the whole amp

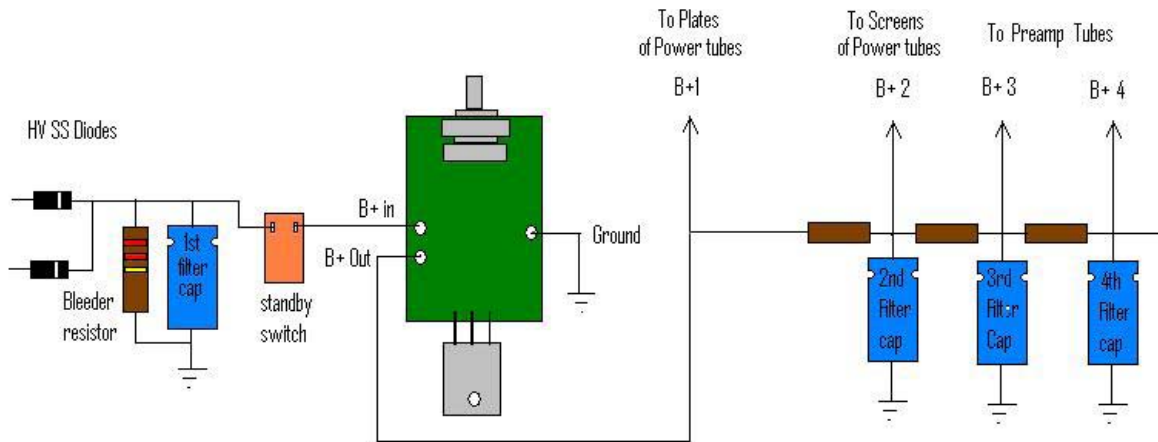

This type installation will turn down ALL of the voltages in the amp as you adjust the power control on the board. This kind of implementation will require you to move the 1meg resistor on your guitar input jack and the installation of a cap between the input and the grid of the first tube. You also need to install another 1meg resistor and cap between the vol control and the grid of the tube it feeds. See the schematics below.

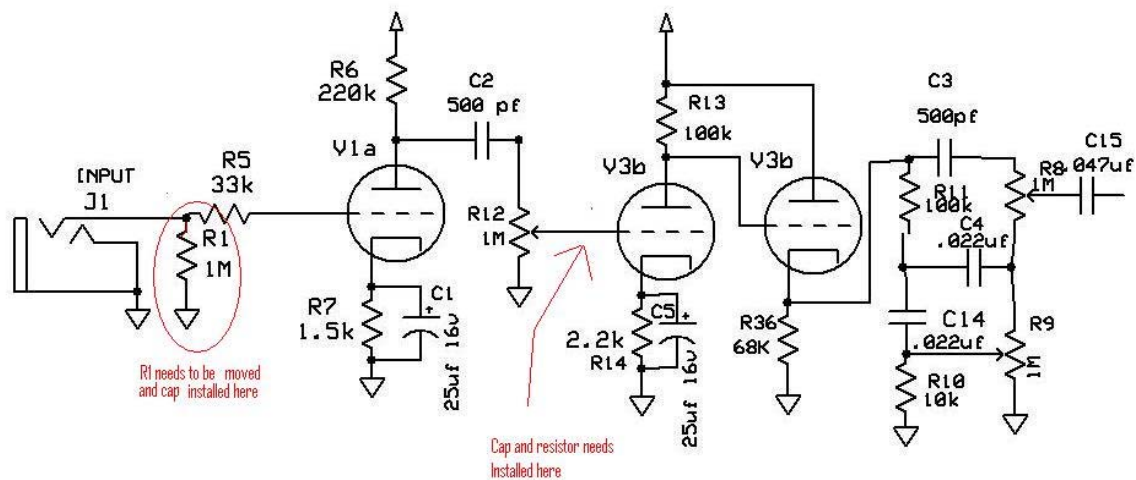

Normal Preamp before installing VVR

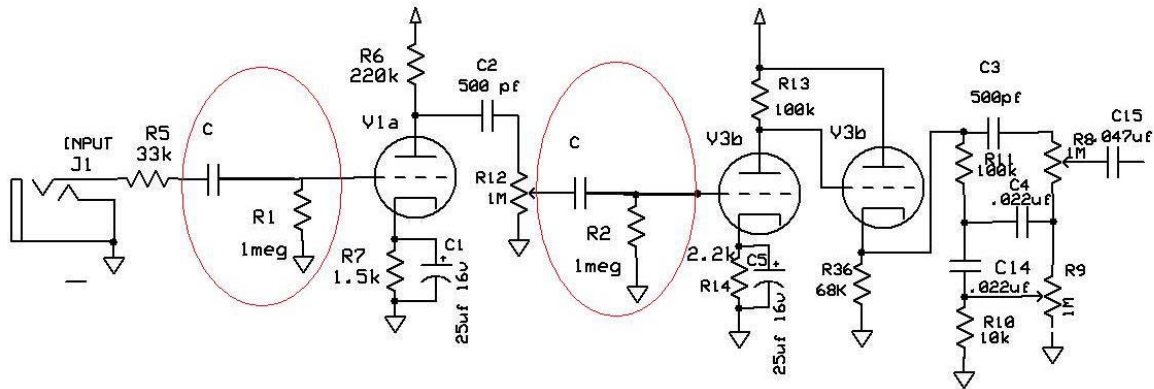

Preamp after moving R1 and adding the 2 capacitors and R2 (circled)

While you can play with the value of the caps a good rule of thumb is to start out with the same size caps that are feeding the signal from your phase inverter to the grids of the power tubes. This should not cause any change in tone compared to the original tone of the amp. Some people just use .1uf. The reason for the changes are because at low voltages the signal on the grids of the two preamp tubes leaks a little dc voltage onto the guitar pot and vol control when the signal hitting these grids drive them more positive than the bias voltage applied. In simple terms it removes the scratchiness from the guitar and amp vol controls.

You can also limit how low the voltage can go so that the grid of the preamp tubes can't leak DC onto the pots. This can be accomplished by changing the value of R1 (and R5 for fixed bias boards). The board comes with a 100k installed for R1 and R5. By changing them to a higher value you will limit how low the voltage will go on the regulator. Basically, they are in series with the 1meg pot. Since the 100k is about 10% of the value of the 1meg pot you limit the voltage to only go down to 10% of the highest voltage. For example, if you had a B+ of 400v and a 100k resistor for R1 you could vary the voltage from 400 v down to 40v (40V being 10% of 400) If you went with a 200k resistor for R1 you could limit the range from 400 to 80v. By limiting how low the voltage goes you can find a point where you won't need to add the caps and 1meg resistor or move the 1meg on the input jack. The only drawback to this method is that you are also limiting the range of how quiet the volume of the amp will go. It is very important to change both R1 and R5 to the same value on the VVR3 fixed bias. If you change the value of R1 you MUST change R5 also.



There is a new feature on the VVR3 board for fixed bias amps that allows you to control the Maximum amount of B+ output from the B+ out on the VVR3. (The VVR for cathode biased amps does not have this feature at this time). If you need to limit the B+ voltage maximum output on a cathode bias amp you will need to purchase a VVR3 and then not use the bias portion of the board. There is a jumper pre installed in the R6 position on the board next to the white 5 watt 10 ohm resistor. To limit the max voltage, you can remove or snip out the jumper and install a resistor in the R6 location. This resistor should be picked as a percentage of the 1 meg pot used to control the VVR3. If you have 400v B+ and you wanted to limit it to 350v then you would need the r6 resistor to drop 50v. To determine the percentage we would divide 50 by 400 which would give us .125. If you multiply .125 x 1000000 (value of VVR pot) you get 125,000 ohms or 125k ohm resistor. So by removing the jumper and installing a 125k ½ watt resistor in the R6 position your B+ would now vary from 350v to 35 volts instead of 400v to 40v.

Regulating the Power Tubes Only

This method is preferred by some, just like regulating the whole amp is preferred by others. This method will split the power supply into 2 different parts. One part is regulated, which supplies voltage to the power tube plates and screens, and the other part is left normal to run the preamp tubes. This method will also require you to make an additional mod to the amp. You will need to add a Master Volume so that the signal coming from the preamp tubes running at normal voltages won't overdrive the power tubes running at reduce voltages. The general consensus is to add a Post Phase Inverter Master volume or PPIMV. This works well in a Push Pull amp but there is no Phase Inverter in a Single Ended amp and a normal Master Volume control will work fine between the last preamp stage and the power tube(s). You will also need to install 2 1N4007 diodes to isolate the two different sections of the power supply so they don't interact with each other. There are a lot of people who like to regulate the Power tubes and PI (Phase Inverter) and leave the preamp voltages unregulated. If you do that then you will need a Master vol installed between the last preamp stage and the PI

Pictorial Diagram of VVR3 Installed Regulating the Power Tubes Only

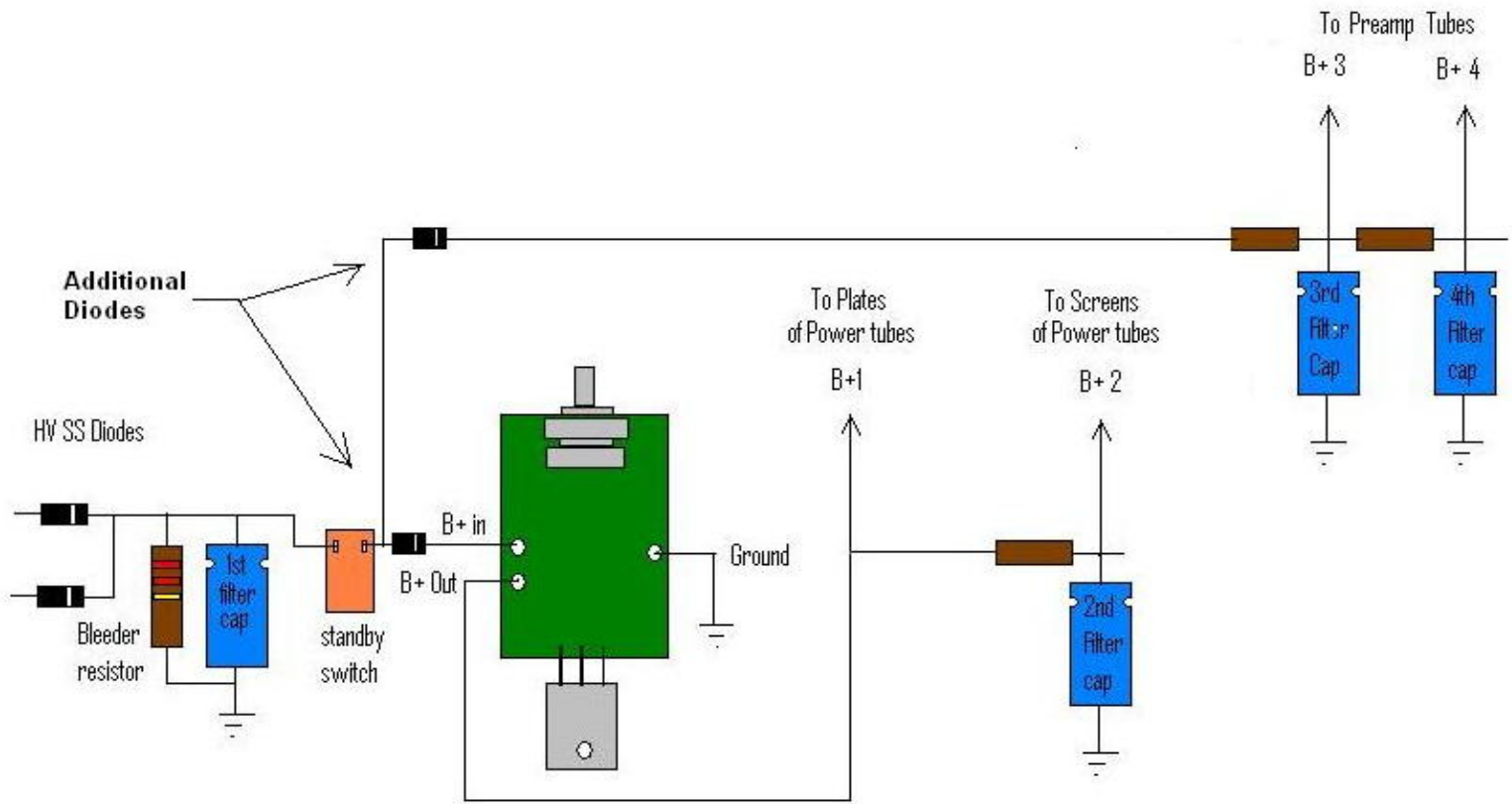

Installing the Fixed Bias Board

The installation of the fixed bias board is identical to the Cathode Biased Board with additional connections for the bias tracking. On the board you find a couple of holes marked C- IN and C- out. This is for the bias voltage. Hooking positive voltage to these pads can damage the bias mosfet. Different bias schemes have been used in many different amps. I have tried to make hooking up the bias part of the board as easy cutting a wire in two and putting the VVR between each end. Your installation may be different.

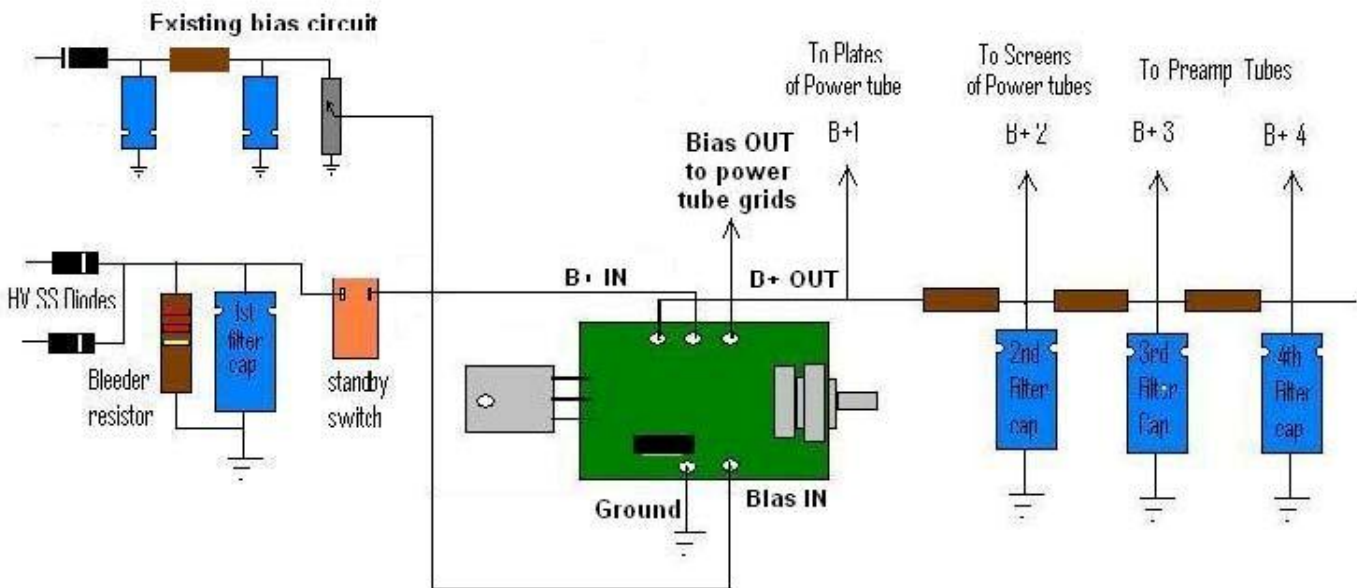

Pictorial Diagram of VVR3 Installed Regulating Bias

Adjusting the Bias

Please see the testing procedure on next page before attempting to set the bias.

There is usually a bias pot in amps that have a fixed bias power supply. The example of one that doesn't would be some Mesa Boogie amplifiers. In an amp that has no bias control find the wire going to the grid resistors of the power tubes. Measure the voltage and if it is negative then disconnect this wire and hook it to the C- IN (Negative Bias IN) on the board. Run another wire from C- OUT on the board back to where you removed the original wire. You will now be able to adjust the bias using the bias control on the board or you can turn the trim pot on the board until your negative voltage reaches its highest (Actually lowest) negative number on a volt meter. This would then give you the original factory setting before you installed the VVR.

If you have an existing bias pot in your amp you have two options. You can max out the original bias control in the amp and use the trimmer on the VVR board to adjust your bias or you can max out the trimmer on the board and use the original bias control to adjust your bias. Please note that if you use the bias pot on the board it will be adjustable from your highest negative bias reading all the way to zero. It is a 1meg pot and a course adjustment. If you decide to use the existing bias pot in the amp you will get whatever range it had to begin with. This is the way to go if you have external jacks and a ten turn pot installed so you don't have to remove the amp chassis from the cab. The procedure to adjust the bias is the same as you would normally use with the exception that you need to make sure the Power Control (Ganged Pot) is set to max B+ voltage. **Setting the bias with the Power control at less than max B+ will cause an over bias condition when the Power Control is set to max.**

Testing

Once the VVR is installed you can test the operation and you will start by removing all of the tubes **EXCEPT FOR THE RECTIFIER TUBE** if it has one. Different amps may have different points so I will identify test points based on VVR component locations. After removing all of the tubes, turn the amp on and let the amp warm up if it has a rectifier tube. Take a meter set to the 1000vdc range and check the output of the rectifier tube to see if high voltage is present. If you have high voltage, go to the next step. NOTE: Some amps have the standby switch in the power transformer CT to ground connection and if yours is like this then you will need to turn on the standby switch to measure the DC output of your rectifier.

Turn the VVR control to the max voltage position, turn your standby switch to operate and measure the voltage at the B+ in side of the VVR board to ground. You should see whatever voltage you measured at the rectifier. If you don't see the voltage then you don't have a proper connection going into the VVR board and you will need to sort that out before proceeding.

Next check the voltage at the B+ out on the VVR board. It should be close to within 20 volts of what you measured on the B+ in side. If it is not then make sure you have the VVR pot set to the Max setting. If the voltage is present, then while monitoring the voltage at B+ out on the board, turn the VVR pot and see if the B+ voltages decrease down to about 10% of full voltage. If that works and you are installing the VVR3 for Fixed bias amps then we will need to check the bias circuit. The next paragraph will explain the bias circuit test. If you are only installing the Cathode bias VVR board, you are finished and can install your tubes and check out the amp.

To test the bias circuit, make sure at least the power tubes are still **removed from the amp** and set your meter to a range near 100vdc. Check the voltage to the Bias IN on the VVR board to ground. **It should read a negative voltage.** With the VVR pot set to max voltage check the Bias out voltage. It should read about the same as the bias in within a volt or two. While monitoring the Bias Out voltage on the board turn the VVR pot and see if the Bias Out voltage decreases to about 10%. If that works then the VVR is operating properly. You can reinstall the tubes and check for normal voltages in the amp with the VVR pot set to max. **Remember to set the bias on the amp with the VVR pot set to max voltage**

If any of the above tests are not correct there is usually a problem with the wiring and you can go to the next page for some troubleshooting tips.

Troubleshooting Tips

Most of the problems I get emails about are ones that are caused by bad wiring or other installation errors that have caused the problems. Here are a few things you can do to try and isolate the problem. Before I get started just a heads up. If it is determined that you have a bad mosfet or zener than **ALWAYS change both**. If you were to change the Mosfet and the zener was bad the bad zener can blow the new replacement mosfet.

Blows fuse on amp. Make sure that you have the clear mica or gray insulator between the mosfet and the chassis.

Swooshing/whistling or oscillating noise when you turn the pot. This is usually caused by bad wire routing. If you are mounting the pot and VVR board or VVR board and mosfet in different locations then try and make sure all of the wires going to and from the VVR board are not bundled with signal wires that can pick up noise from the VVR wiring or vice versa. Always try and have signal and power wires crossing at right angles and use good tidy wiring layouts.

Noise or static on the guitar pots or volume pot at very low voltage settings is caused by small amounts of DC leaking onto the grid of the preamp tubes. Read pages 3/4 to correct the problem

When you turn the VVR pot the volume drop is gradual and not instantaneous. This is normal. The volume drops or increases as the filter caps in the amp charge or discharge and it takes a second for that to stabilize. Normally, you aren't going to be adjusting the VVR while playing and this shouldn't be a problem.

The voltage stays the same at B+ Out when I turn the pot. First unsolder the wire going to the B+ out and check to see if the voltage varies. If it does then you have a problem with your wiring. If it does not, then there is a problem with the VVR board. If the problem is on the VVR board, then measure the voltage at the wiper (middle Lug) on the pot. If you have a VVR3 for fixed bias then this would be the middle lug on the pot closest to the front of the pot where the shaft comes out. If it varies there, but not at the B+ out of the VVR board then you may have a bad ground going to the VVR board or a bad mosfet or Zener diode. Always change them both at the same time making sure you get the band on the zener pointing the correct way.

Feel free to send me an email to info@hallamplification.com if you have any other problems or questions

**NTE2973
 MOSFET
 N-Channel, Enhancement Mode
 High Speed Switch**

Applications:

- SMPS
- DC-DC Converter
- Battery Charger
- Power Supply of Printer
- Copier
- HDD, FDD, TV, VCR
- Personal Computer

Absolute Maximum Ratings: ($T_C = +25^\circ\text{C}$ unless otherwise specified)

Drain-Source Voltage ($V_{GS} = 0\text{V}$), V_{DSS}	900V
Gate-Source Voltage ($V_{DS} = 0\text{V}$), V_{GS}	$\pm 30\text{V}$
Drain Current, I_D	
Continuous	14A
Pulsed	42A
Maximum Power Dissipation, P_D	275W
Channel Temperature Range, T_{ch}	-55° to $+150^\circ\text{C}$
Storage Temperature Range, T_{stg}	-55° to $+150^\circ\text{C}$
Thermal Resistance, Channel-to-Case, $R_{th(ch-c)}$	0.45°C/W

Electrical Characteristics: ($T_{ch} = +25^\circ\text{C}$ unless otherwise specified)

Parameter	Symbol	Test Conditions	Min	Typ	Max	Unit
Drain-Source Breakdown Voltage	$V_{(BR)DSS}$	$V_{DS} = 0\text{V}$, $I_D = 1\text{mA}$	900	-	-	V
Gate-Source Breakdown Voltage	$V_{(BR)GSS}$	$V_{DS} = 0\text{V}$, $I_G = \pm 100\mu\text{A}$	± 30	-	-	V
Gate-Source Leakage	I_{GSS}	$V_{GS} = \pm 25\text{V}$, $V_{DS} = 0\text{V}$	-	-	± 10	μA
Zero Gate Voltage Drain Current	I_{DSS}	$V_{DS} = 900\text{V}$, $V_{GS} = 0$	-	-	1.0	mA
Gate Threshold Voltage	$V_{GS(th)}$	$V_{DS} = 10\text{V}$, $I_D = 1\text{mA}$	2.0	3.0	4.0	V
Static Drain-Source ON Resistance	$R_{DS(on)}$	$V_{GS} = 10\text{V}$, $I_D = 7\text{A}$	-	0.63	0.85	Ω
Drain-Source On-State Voltage	$V_{DS(on)}$	$V_{GS} = 10\text{V}$, $I_D = 7\text{A}$	-	4.41	5.95	V
Forward Transfer Admittance	$ y_{fs} $	$V_{GS} = 10\text{V}$, $I_D = 7\text{A}$	9	15	-	S

Electrical Characteristics (Cont'd): ($T_{ch} = +25^{\circ}\text{C}$ unless otherwise specified)

Parameter	Symbol	Test Conditions	Min	Typ	Max	Unit
Input Capacitance	C_{iss}	$V_{GS} = 0\text{V}, V_{DS} = 25\text{V}, f = 1\text{MHz}$	-	2900	-	pF
Output Capacitance	C_{oss}		-	290	-	pF
Reverse Transfer Capacitance	C_{rss}		-	50	-	pF
Turn-On Delay Time	$t_{d(on)}$	$V_{DD} = 200\text{V}, I_D = 7\text{A}, V_{GS} = 10\text{V},$ $R_{GEN} = R_{GS} = 50\Omega$	-	45	-	ns
Rise Time	t_r		-	65	-	ns
Turn-Off Delay Time	$t_{d(off)}$		-	325	-	ns
Fall Time	t_f		-	100	-	ns
Diode Forward Voltage	V_{SD}	$I_S = 7\text{A}, V_{GS} = 0\text{V}$	-	1.0	1.5	V

