

# MAGNATONE – ESTEY

MUSICAL INSTRUMENT AMPLIFIER

MODEL M-10A

66-3121

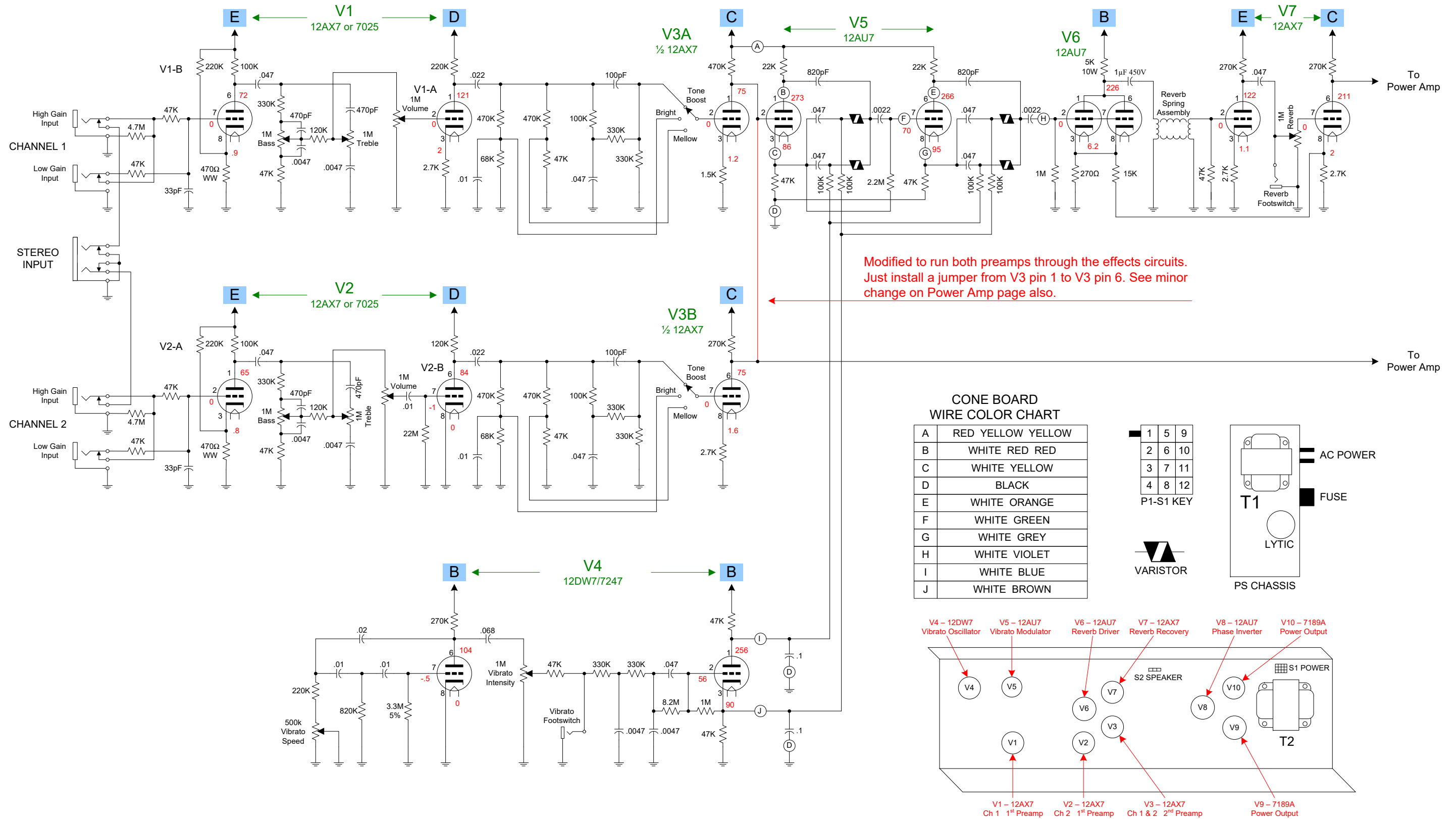

# MAGNATONE – ESTEY

MODEL M-10A  
POWER SUPPLY AND POWER AMP

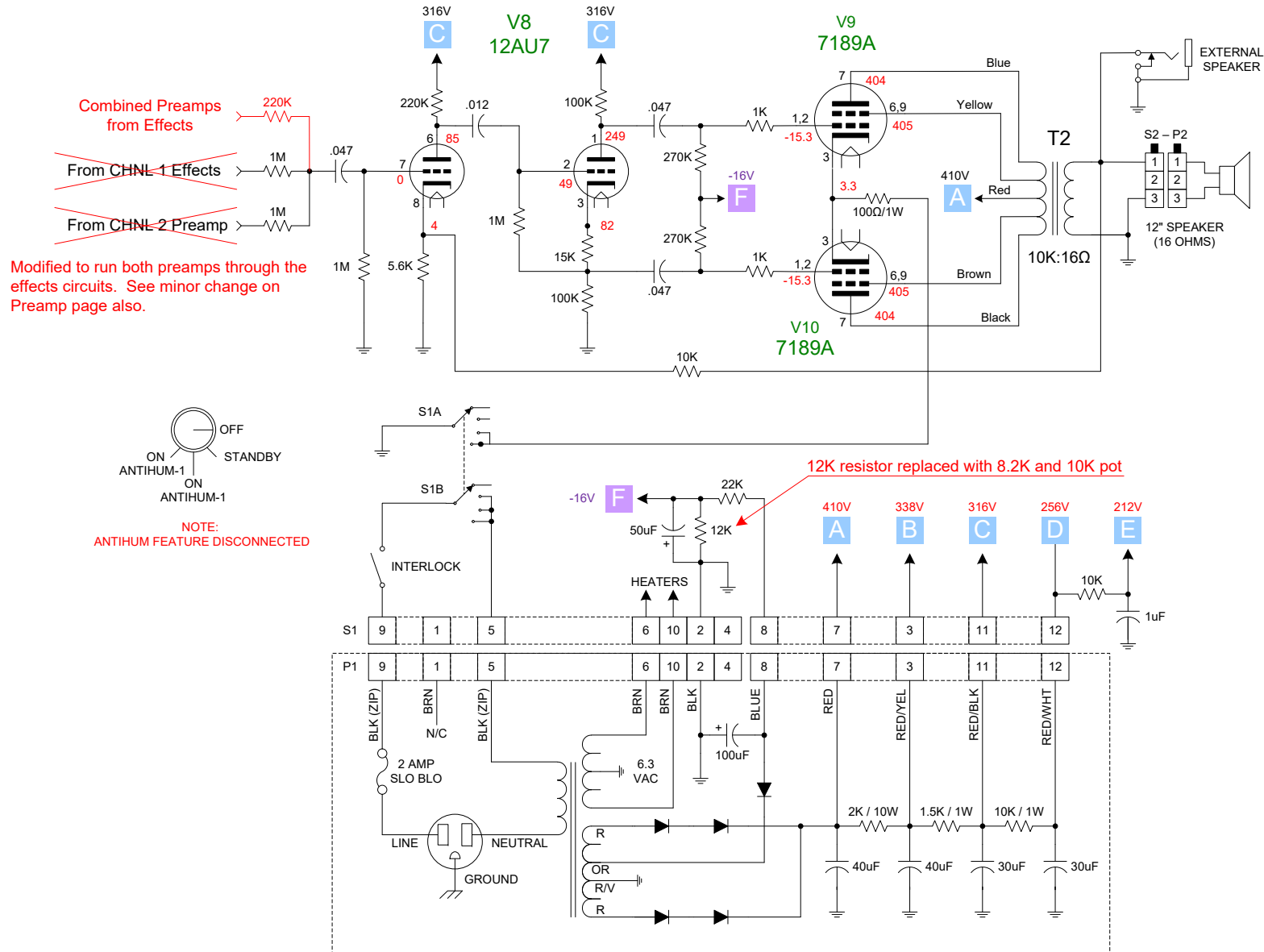

# MAGNATONE – ESTEY

## MODEL M-10A NOTES AND EXTRAS

TUBE VOLTAGE CHART

	1	2	3	4	5	6	7	8	9
V1	121	0	2	HTR	HTR	72	0	0.9	HTR
V2	65	0	0.8	HTR	HTR	84	-1.0	0	HTR
V3	75	0	1.2	HTR	HTR	75	0	1.6	HTR
V4	256	56	90	HTR	HTR	104	-0.5	0	HTR
V5	273	75	86	HTR	HTR	266	70	95	HTR
V6	226	0	6.2	HTR	HTR	226	0	6.2	HTR
V7	122	0	1.1	HTR	HTR	211	0	2	HTR
V8	241	49	82	HTR	HTR	85	0	4	HTR
V9	-15.3	-15.3	3.3	HTR	HTR	405	404	X	405
V10	-15.3	-15.3	3.3	HTR	HTR	405	404	X	405

Voltages measured with Fluke 87 DMM referenced to chassis. All controls set to max CCW. V4 phase shift oscillator was disabled by shorting out the 820K resistor.

CONE BOARD  
WIRE COLOR CHART

A	RED YELLOW YELLOW
B	WHITE RED RED
C	WHITE YELLOW
D	BLACK
E	WHITE ORANGE
F	WHITE GREEN
G	WHITE GREY
H	WHITE VIOLET
I	WHITE BLUE
J	WHITE BROWN

1	5	9
2	6	10
3	7	11
4	8	12

P1-S1 KEY



Pot codes: 304-6532  
Mfg is Stackpole  
Date is 32th week of 1965

TUBE LOCATOR

