

Harmonic Twin Rebuild - Work in progress

V.0.6 - 16.07.20

-Jakob H.

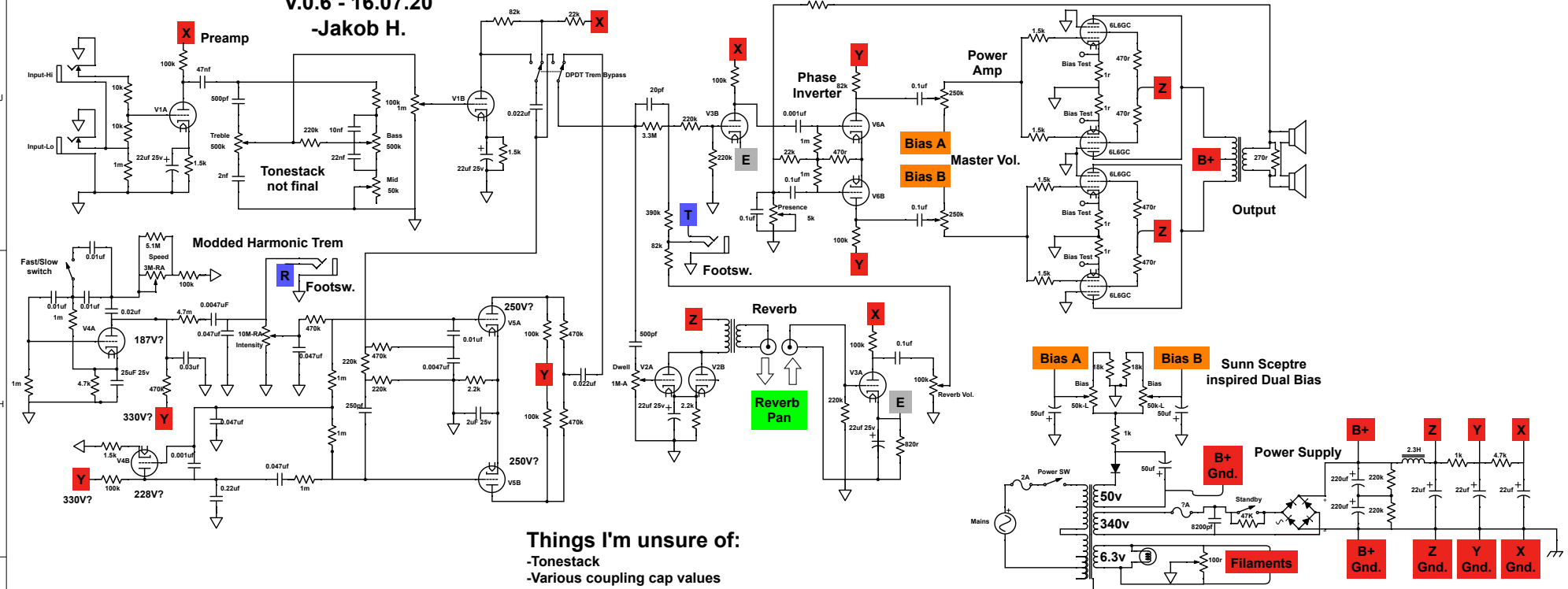

Things I'm unsure of:

- Tonestack
- Various coupling cap values
- NFB values
- Bias circuit values
- Placement of standby switch in circuit
- Mixing section between V1B and V3B
- I am fine with trem bypass sw. causing pops. Will switch only in standby