

Vox AC-30.4 Lite

Designed by Steve Luckey

09/25/2020

Modified 15 Watt version

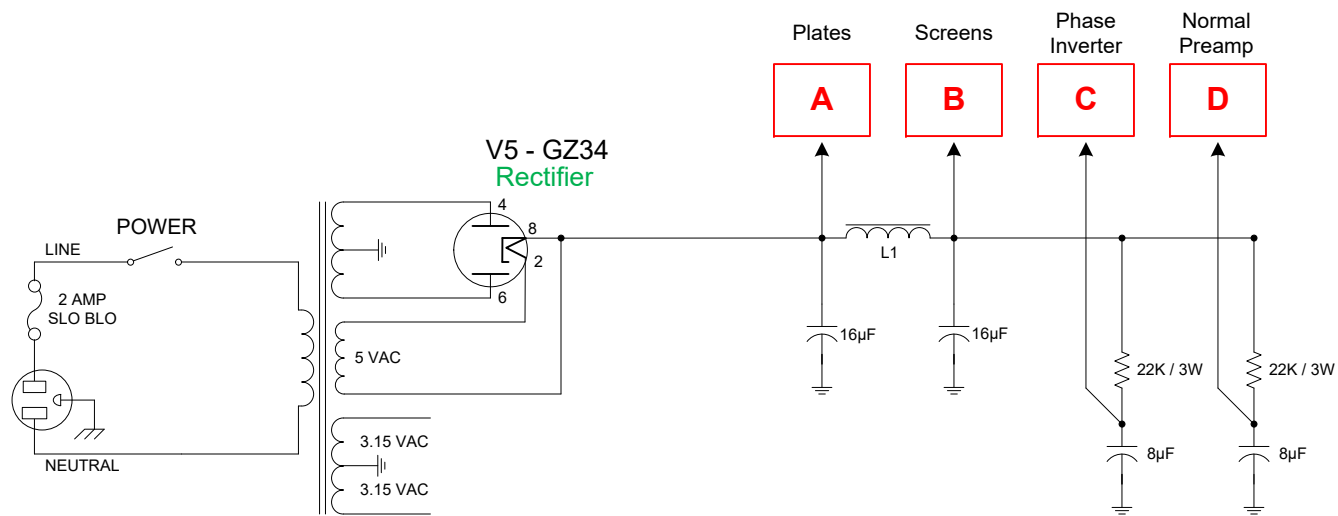
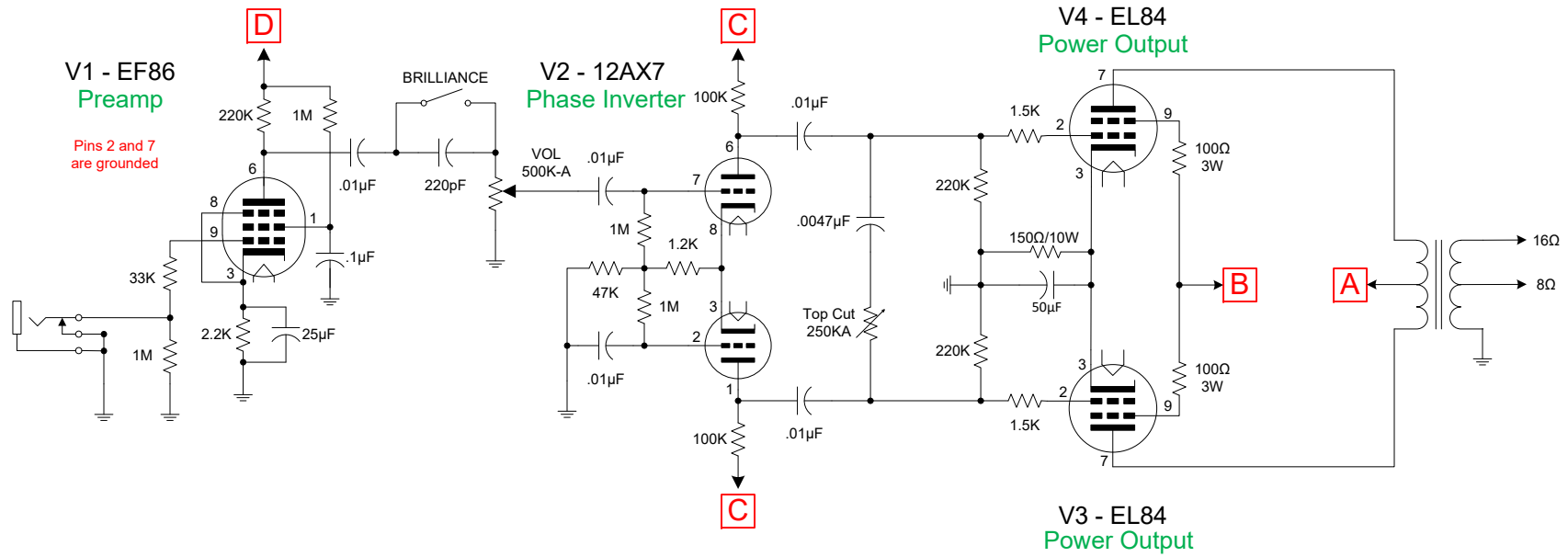

Vox AC-30.4 Lite

Designed by Steve Luckey
09/25/2020

Modified 15 Watt version

Chassis 12" x 6.5" x 2.5"

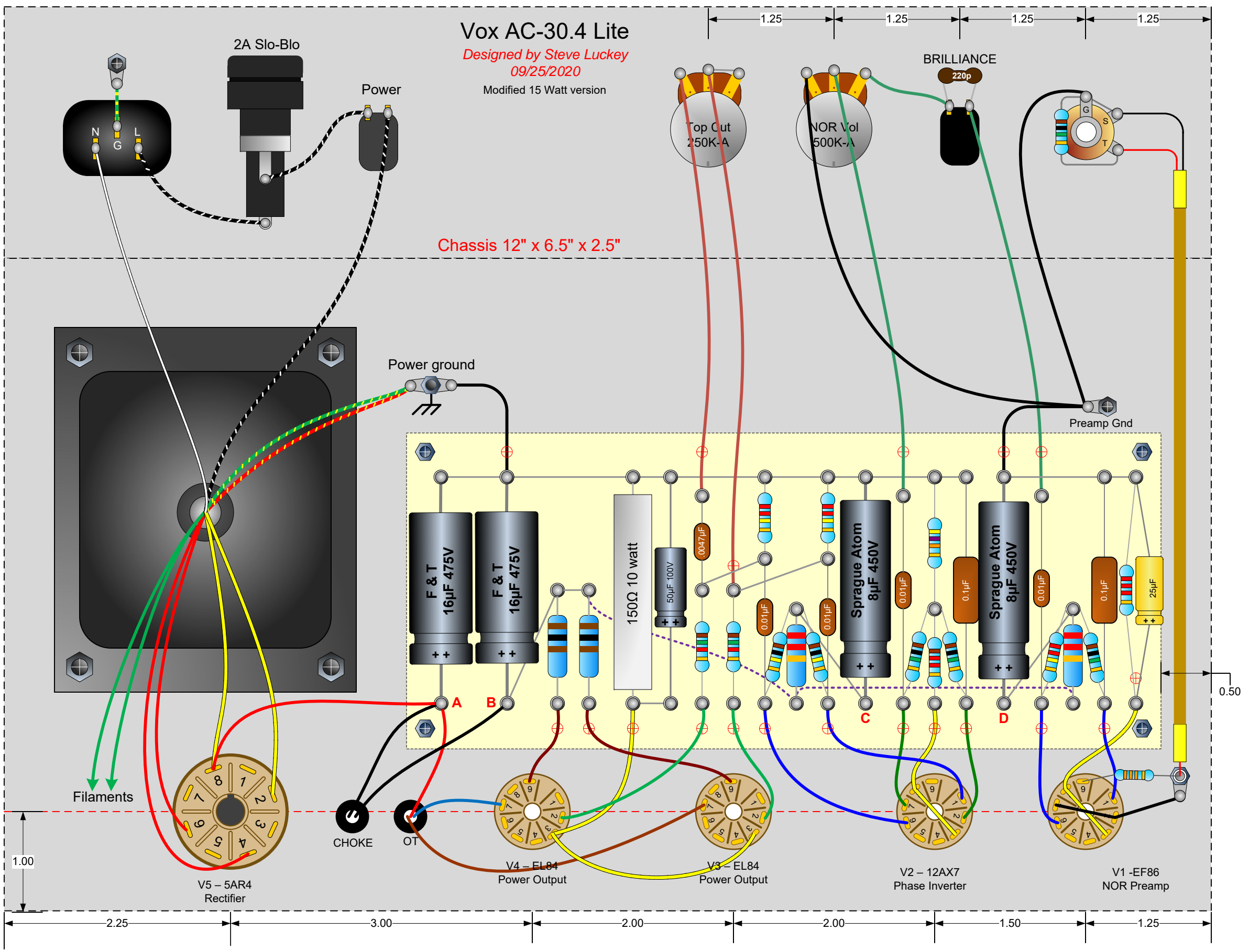

BOARD DRILL/JUMPER GUIDE

INSTRUCTIONS FOR USING THIS DRILL GUIDE

- ⊕ Turret --- drill size is 3/32"
- ⊕ Standoff – drill size to fit
- ⊕ Hole for wire pass-thru – drill size to fit
- Dashed lines are underboard jumpers

Board size is 3-1/8" X 7-1/2". Print two copies of this page FULL SIZE on letter sized paper. Measure the board length of the printout to verify it is 7-1/2". Use one template as a drill guide. Attach to blank board using double sided carpet tape or spray adhesive. Use a center punch to put a mark at the cross hairs of each turret, standoff, and wire pass-thru hole. Use a 3/32" drill bit to drill all holes. Then enlarge standoff holes and wire pass-thru holes as needed. Remove template and load turrets.

Use the other template to install jumpers. Use a highlighter to mark each jumper as you install it.

