

# Rick-Tone

MAKE / MODEL

Rick-Tone "Tube-0-Drive"

DESCRIPTION

Volume Boost (Overdrive) Effect For Guitar  
(Redrawn on computer in July 2007 from my old hand-drawn schematics circa 1980's)

DRAWING TYPE

Electrical Schematic

DRAWN BY

Rick Campbell

**PLEASE NOTE:** These devices underwent many changes and improvements over the time span that they were produced, and were often custom-tailored to individual owner's tastes. While this drawing may serve as a general overview for the circuit of this type/model of device, it is quite possible that the circuit of your individual Rick-Tone device may not match this drawing in every detail.

**CAUTION! ELECTRICAL SHOCK HAZARD:** Vacuum tube circuits can contain dangerous high voltage electricity that can be harmful or even lethal if appropriate safety measures are not observed. Dangerous voltages may even still be present when the unit is turned off and unplugged. Do not attempt to repair, modify, touch, or build such circuits without proper training.

**DISCLAIMER:** This diagram is provided for informational/educational use only. Any use is AT YOUR OWN RISK. The authors and distributors of this diagram disclaim any and all liability for consequences of your use of this drawing and its contents.

## POWER SUPPLY SECTION

All resistors are 1/2 watt unless otherwise marked.  
All capacitors are 400v unless otherwise marked.

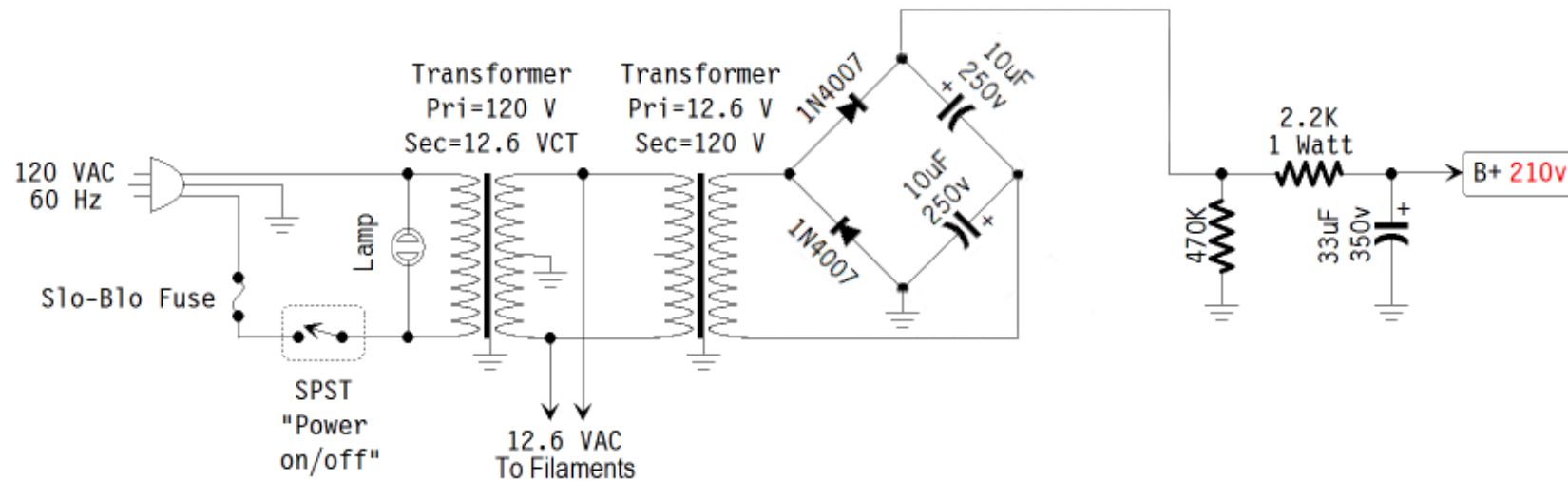

## EFFECT SECTION

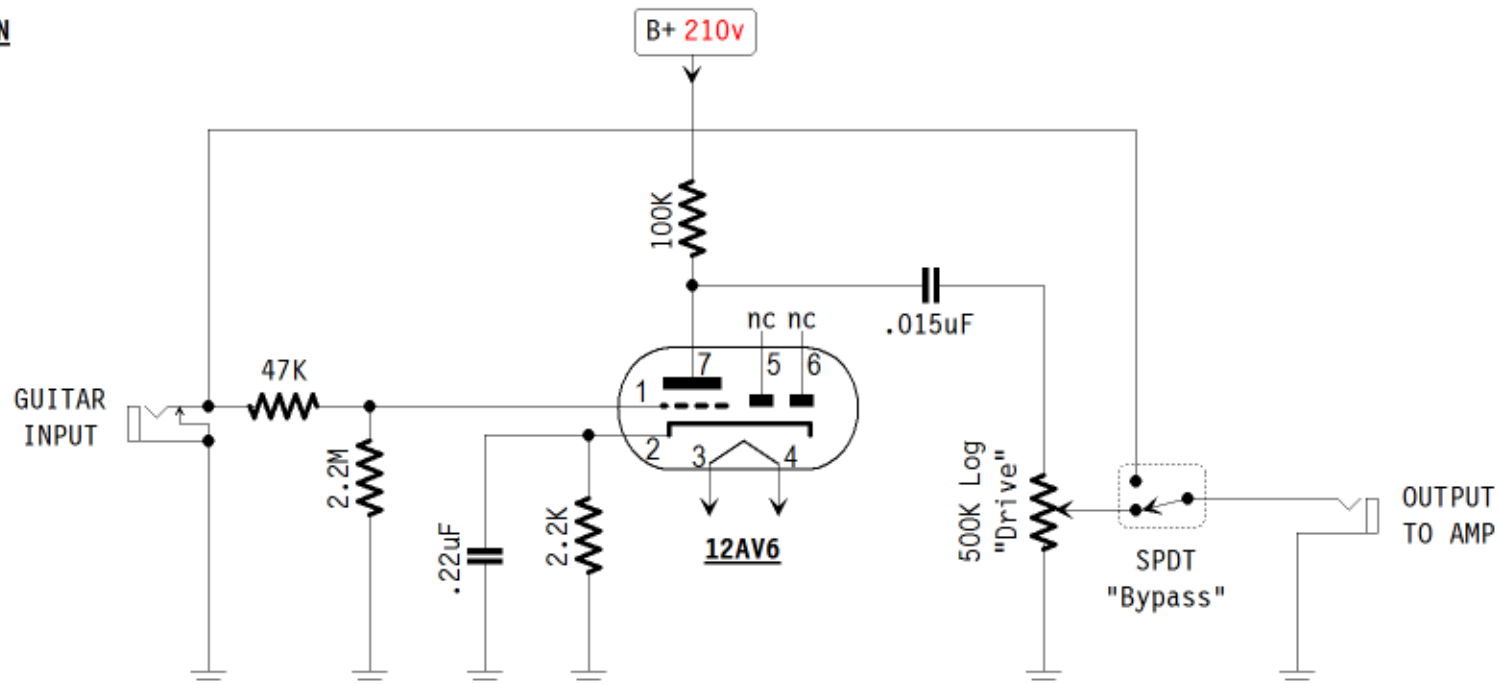

## GENERAL DESCRIPTION

This is a simple tube-based volume boost or 'overdrive' device. The triode tube is configured to act as a simple voltage amplifier to boost the level of the incoming guitar signal. The power supply uses two inexpensive 12 volt transformers wired back-to-back to provide both the filament voltage and high voltage power for the circuit. A voltage doubler circuit is used to further increase the power supply voltage for the tube. The bypass switch leaves the input of the device connected to the guitar in both positions, but the input impedance of the device is so high that it doesn't noticeably load down the guitar's magnetic pickup.