

# Magnatone Twilighter Lite

by slucky 03/14/2021

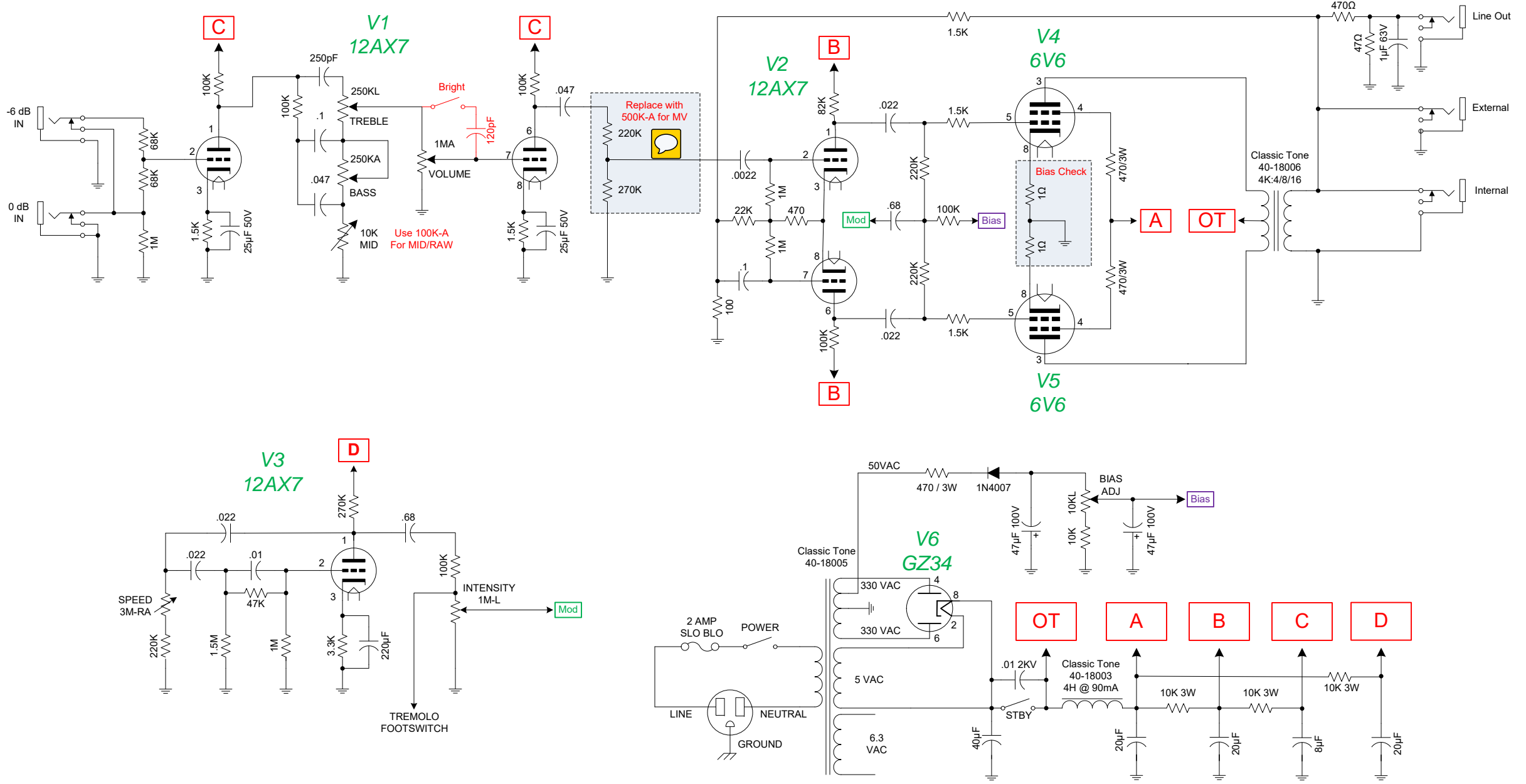



# DRILL GUIDE

## INSTRUCTIONS FOR USING DRILL GUIDE

⊕ Turret --- drill size is 3/32"

⊕ Standoff – drill size to fit

⊕ Hole for wire pass thru – drill size to fit

----- Dashed lines are underboard jumpers

Board size is 3-1/8" X 8-5/16". Print two copies of this drill guide FULL SIZE on letter sized paper. One copy will be used as a drill guide. The other copy will be used for installing jumpers. Measure the board length of the printout to verify it is 8-5/16". Attach to blank board using double sided carpet tape or spray adhesive. Use a center punch to put a mark at the cross hairs of each turret and standoff. Use a 3/32" drill bit to drill all holes. Then enlarge standoff holes as needed for screws. Use mineral spirits and/or denatured alcohol to remove drill guide from board.

